

**TECHNICAL MANUAL**  
**OPERATOR'S, UNIT, AND DIRECT SUPPORT**  
**MAINTENANCE MANUAL INCLUDING**  
**REPAIR PARTS AND SPECIAL TOOLS LIST**  
**FOR**  
**MODULAR FIELD KITCHEN (MFK)**  
**NSN 7360-01-276-9817 (EIC:YCD)**

Approved for public release;  
 Distribution is unlimited.

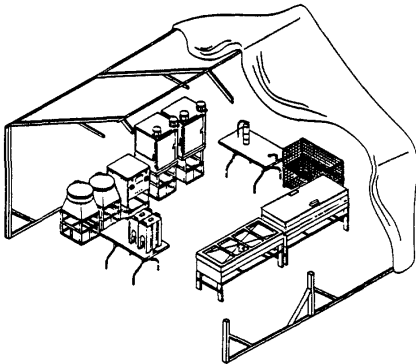

<b>INTRODUCTION</b>	<b>1-1</b>
<b>OPERATING INSTRUCTIONS</b>	<b>2-1</b>
<b>OPERATOR MAINTENANCE INSTRUCTIONS</b>	<b>3-1</b>
<b>UNIT MAINTENANCE INSTRUCTIONS</b>	<b>4-1</b>
<b>DIRECT SUPPORT MAINTENANCE INSTRUCTIONS</b>	<b>5-1</b>
<b>REFERENCES (APPENDIX A)</b>	<b>A-1</b>
<b>MAINTENANCE ALLOCATION CHART (APPENDIX B)</b>	<b>B-1</b>
<b>COMPONENTS OF END ITEM AND BASIC ISSUE ITEMS UST (APPENDIX C)</b>	<b>C-1</b>
<b>ADDITIONAL AUTHORIZATION LIST (APPENDIX D)</b>	<b>D-1</b>
<b>EXPENDABLE/DURABLE SUPPLIES AND MATERIALS LIST (APPENDIX E)</b>	<b>E-1</b>
<b>REPAIR PARTS AND SPECIAL TOOLS LIST (APPENDIX F)</b>	<b>F-1</b>
<b>ILLUSTRATED LIST OF MANUFACTURED ITEMS</b>	<b>G-1</b>
<b>ALPHABETICAL INDEX</b>	<b>INDEX 1</b>



**WARNING****CARBON MONOXIDE GAS CAN KILL YOU**

- Carbon monoxide occurs in exhaust fumes of fuel-burning equipment such as the M2/M2A burner units, and internal combustion engines. Carbon monoxide can reach dangerous concentrations under conditions of no air movement. Precautions must be followed to insure crew safety when you operate this equipment.
- Carbon monoxide gas is not visible and it has no smell, but it can kill you. Breathing air with carbon monoxide produces symptoms of headache, dizziness, loss of muscular control, a sleepy feeling, and coma. Brain damage or death can result from heavy exposure.
- **OPEN** vents to provide ventilation and prevent the accumulation of carbon monoxide gas.
- **BE ALERT** at all times during MFK operation for exposure symptoms. **IMMEDIATELY VENTILATE** the tent. If symptoms persist, move affected crew to fresh air and keep warm.

**DO NOT PERMIT PHYSICAL EXERCISE:**  
if necessary, give artificial respiration.

**FOR ARTIFICIAL RESPIRATION REFER TO FM 21-11**

**THE BEST DEFENSE AGAINST CARBON MONOXIDE POISONING IS  
GOOD VENTILATION.**

- Flammable liquids are used in the operation of the MFK. Death or severe injury may result from explosion or fire if personnel fail to observe the correct operating procedures for burner units.
- Do not pressurize fuel tanks with anything other than the hand air pump to obtain starting pressure. If a fuel leak is detected, shut the unit off immediately. Do not operate the unit again until the deficiency has been corrected.
- If the flame goes out for any reason during operation, immediately close the generator flame valve to prevent accumulation of fuel and possible explosion.
- Allow burner units and lanterns to cool before releasing air pressure from fuel tanks. Do not smoke and make sure there is no open flame in the vicinity. Fuel fumes are explosive and highly flammable.
- If the pressure gage reaches the red area, immediately shut off the burner unit and remove it from the MFK. Allow unit to cool before placing back in operation.
- To prevent fires do not use flammable material as a base for the MFK. Fire may cause injury or death to personnel or damage the equipment.
- Establish a safe lighting area that is a minimum of 50 feet (15.3 meters) from the servicing, refueling, fuel storage, cooling and sanitizing area.
- When filling the fuel tank, always provide a metal to metal contact between the container and the fuel tank to avoid explosion from static electricity.
- Extreme heat will cause tank pressure to increase because of fuel expansion. Make sure you start with prescribed pressure in accordance with TM 10-7360-204-13&P.
- Do not fill the burner unit fuel tanks unless the burner unit is turned off and has been allowed to cool.

- The burner units should be moved a minimum of 50 feet (15.3 meters) from the MFK and the fuel storage area prior to servicing. Do not smoke and ensure that there is no open flame in vicinity; fire or explosion may result.
- Make sure you leave enough air space between the tent wall and the MFK equipment. When the M2 burner units are lit, they get hot. Frequently check for heating of the tent wall while the M2 burner units are in use. Move the M2 burner units further away from tent wall if necessary. If they are too close to the tent wall, they could ignite the tent.
- Gasoline lanterns should be suspended only from a tent frame member. Lanterns should be located where the header and arch are secured together. Allow a minimum of 12 inches (30.5 cm) between the top of the lantern and the tent liner fabric. (See TM 10-8340-224-13). Place lanterns so that they will not be knocked down by or cause injury to personnel walking through the tent. Using 0.25 inch rope (manila), or wire secure the lantern and the liner or any fabric. After lantern is in place fasten the hook and pile connecting liner sections together.
- Allow lanterns to cool before releasing air pressure from the fuel tank Do not smoke and make sure there is no open flame in the vicinity. Fuel fumes are explosive and highly flammable.
- Do not add fuel to lanterns inside the MFK tent.
- Do not hang fire extinguisher where you would have to walk through a possible fire to reach it.
- Do not hang the fire extinguisher in an extremely hot or cold location (The nameplate on the unit tells you the exact temperatures it can withstand). Never throw it in a fire as it could explode.
- Familiarize yourself with the location of the fire extinguisher and MFK exits. Make sure that a fire extinguisher is at hand when operating or servicing the burner units.
- Bleed all burner units and lanterns of air before storage.
- Drain all fuel from equipment into fuel can before movement or storage, \* Dry cleaning solvent, A-A-711 TY 1, used to dean parts is potentially dangerous to personnel and property. Avoid repeated and prolonged skin contact by wearing rubber or non-porous gloves when handlingthe solvent or material wet with dry cleaning solvent. Wash hands immediately after exposure with soap and water and use a lanolin based skin cream to prevent skin drying. Do not use near open flame or excessive heat. Flash point of solvent is 100°F (38°). Do not work with solvent in a dosed room. Be sure there is good ventilation or the solvent vapors will build up in the air and become a poisonous mixture which can cause physical injury or even death.
- During operation of the griddle assembly, check grease accumulation. Excessive grease either on the griddle or in the container below the griddle poses a fire hazard. A grease fire may cause injury to personnel and equipment.
- Do not put milk and dairy type products in the insulated liquid dispenser. The dispenser cannot be thoroughly cleaned of dairy product residues that will contaminate other liquids and may cause food poisoning.

- Do not use tray-packs having any of the following defects:
  1. Leaks that show evidence of pack contents on the tray exterior due to pinhole, pack fracture or incomplete seal.
  2. Rust that actually penetrates the tray-pack, causing leakage, or excessive end seam corrosion that cannot be removed with a soft cloth and would enter the product when the tray-pack is opened.
  3. Severe dents that cause leakage of pack contents or otherwise affect usability.
  4. Swollen or outwardly distended tray lids bulging from Internal pressure, or swells caused by physical damage such as dents or overheating.
  5. Buckles or bends in the top, extending into the end seam of the tray-pack.

Dispose of tray-packs with any of the above defects as directed by veterinary personnel.

- Handle tray-pack lids and trash bags containing tray-pack lids carefully. Sharp edges on open lids may cause serious cuts.
- Serious injury could occur if heavy equipment is moved/lifted without sufficient personnel to do the job. Use proper physical lifting procedures or use a suitable lifting device or dolly. Wear safety shoes, gloves and other suitable protective clothing.



CHANGE  
NO. 7

HEADQUARTERS,  
DEPARTMENT OF THE ARMY  
WASHINGTON, D.C., 30 SEPTEMBER 2005

TECHNICAL MANUAL  
OPERATOR'S, UNIT, AND DIRECT SUPPORT  
MAINTENANCE MANUAL  
INCLUDING REPAIR PARTS AND SPECIAL TOOLS LIST  
FOR  
MODULAR FIELD KITCHEN (MFK)  
NSN 7360-01-276-9817 (EIC:YCD)

**DISTRIBUTION STATEMENT A:** - Approved for public release; distribution is unlimited.

TM 10-7360-208-13&P, dated 9 September 1991, is changed as follows:

1. File this sheet in the front of the manual for reference.
2. This change implements the Army Maintenance Transformation and changes the Maintenance Allocation Chart (MAC) to Support Field and Sustainment Maintenance.
3. New or updated text is indicated by a vertical bar in the outer margin.
4. Added illustrations are indicated by a vertical bar adjacent to the figure number. Changed illustrations are indicated by a miniature hand adjacent to the updated area and a vertical bar adjacent to the figure number.
5. Remove old pages and insert new pages as indicated below.

**Remove Pages**

A/(B Blank)  
B-1 – B-8  
Electronic 2028 Instructions  
Sample 2028 – Front

**Insert Pages**

A/(B Blank)  
B-1 – B-8  
Electronic 2028 Instructions/(Blank)  
Sample 2028 – Front/Back  
2028 – Front/Back  
2028 – Front/Back

By Order of the Secretary of the Army:  
C7

**PETER J. SCHOOMAKER**  
*General, United States Army*  
*Chief of Staff*

Official:

  
**SANDRA R. RILEY**  
Administrative Assistant to the  
Secretary of the Army  
0525006

DISTRIBUTION:

To be distributed in accordance with initial distribution number (IDN) 255473 requirements for  
TM 10-7360-208-13&P.



CHANGE

NO. 6

HEADQUARTERS  
DEPARTMENT OF THE ARMY  
WASHINGTON, D.C., 10 October 1996

Operator's, Unit, and Direct Support  
Maintenance Manual Including  
Repair Parts and Special Tools List

For

**MODULAR FIELD KITCHEN (MFK)  
NSN 7360-01-276-9817 (EIC:YCD)**

DISTRIBUTION STATEMENT A: Approved for public release; distribution is unlimited.

TM 10-7360-208-13&P, 9 September 1991, is changed as follows:

1. Remove and insert pages as indicated below. New or changed text material is indicated by a vertical bar in the margin. An illustration change is indicated by a miniature pointing hand.

**Remove pages**

a and b  
i and ii  
1-3 through 1-6  
2-3 and 2-4  
2-7 and 2-8  
2-21 and 2-22  
2-33 and 2-34  
2-53 and 2-54  
3-1 and 3-2  
4-5 and 4-6  
5-1 and 5-2  
A-1/(A-2 blank)  
B-7 and B-8  
C-9 and C-10  
C-17 through C-20  
E-1 and E-2  
F-49 and F-50  
F-55 through F-58  
F-61 and F-62

**Insert pages**

a and b  
i and ii  
1-3 through 1-6  
2-3 and 2-4  
2-7 and 2-8  
2-21 and 2-22  
2-33 and 2-34  
2-53 and 2-54  
3-1 and 3-2  
4-5 and 4-6  
5-1 and 5-2  
A-1/(A-2 blank)  
B-7 and B-8  
C-9 and C-10  
C-17 through C-20  
E-1 and E-2  
F-49 and F-50  
F-55 through F-58  
F-61 and F-62

2. Retain this sheet in front of manual for reference purposes.

**By Order of the Secretary of the Army:**

DENNIS J. REIMER  
*General, United States Army*  
*Chief of Staff*

Official:



*Administrative Assistant to the*  
*Secretary of the Army*  
03040

**DISTRIBUTION:**

To be distributed in accordance with DA Form 12-25-E, block no. 5473, requirements for TM 10-7360-208-13&P.

CHANGE  
NO. 5

HEADQUARTERS  
DEPARTMENT OF THE ARMY  
WASHINGTON, D.C., 3 August 1995

Operator's, Unit, and Direct Support  
Maintenance Manual Including Repair Parts  
and Special Tools List for

**MODULAR FIELD KITCHEN (MFK)  
NSN 7360-01-276-9817 (EIC: YCD)**

DISTRIBUTION STATEMENT A: Approved for public release; distribution is unlimited

TM 10-7360-208-13&P, 9 September 1991, is changed as follows:

1. Remove and insert pages as indicated below. New or changed text material is indicated by a vertical bar in the margin. An illustration change is indicated by a miniature pointing hand.

Remove pages

C-1 and C-2  
C-5 through C-10  
C-15 through C-18  
F-11 and F-12  
F-55 and F-56

Insert pages

C-1 and C-2  
C-5 through C-10  
C-15 through C-18  
F-11 and F-12  
F-55 and F-56

2. Retain this sheet in front of manual for reference purposes.

By Order of the Secretary of the Army:

Official:

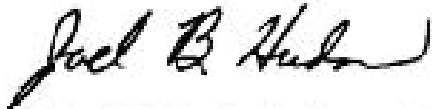

*Acting Administrative Assistant to the  
Secretary of the Army*

00769

DENNIS J. REIMER  
*General, United States Army  
Chief of Staff*

**DISTRIBUTION:**

To be distributed in accordance with DA Form 12-25-E, block no. 5473, requirements for TM 10-7360-208-13&P.

CHANGE

NO. 4

HEADQUARTERS  
DEPARTMENT OF THE ARMY  
WASHINGTON, D.C., 17 January 1995

Operator's, Unit, Direct Support  
Maintenance Manual including  
Repair Parts and Special Tools List  
for

**MODULAR FIELD KITCHEN (MFK)  
NSN 7360-01-276-9817 (EIC: YCD)**

DISTRIBUTION STATEMENT A: Approved for public release; distribution is unlimited

TM 10-7360-208-13&P, 9 September 1991, is changed as follows:

1. Remove and insert pages as indicated below. New or changed text material is indicated by a vertical bar in the margin. An illustration change is indicated by a miniature pointing hand.

Remove pages  
a and b  
i and ii  
1-9/(1-10 blank)  
2-55 and 2-56  
C-1 through C-4  
E-1 and E-2  
F-7 through F-62

Insert pages  
a and b  
i through iii/(iv blank)  
1-9/(1-10 blank)  
2-55 and 2-56  
C-1 through C-4  
E-1 and E-2  
F-7 through F-62

2. Retain this sheet in front of manual for reference purposes.

By Order of the Secretary of the Army:

Official:



*Administrative Assistant to the  
Secretary of the Army*  
07551

GORDON R. SULLIVAN  
General, United States Army  
Chief of Staff

DISTRIBUTION:

To be distributed in accordance with DA Form 12-25-E, block no. 5473, requirements for TM 10-7360-208-13&P.



CHANGE

NO. 3

HEADQUARTERS  
DEPARTMENT OF THE ARMY  
WASHINGTON, D.C., 31 August 1993Operator's Unit, and Direct Support  
Maintenance Manual Including Repair Parts  
and Special Tools List**MODULAR FIELD KITCHEN (MFK)**  
**NSN 7360-01-276-9817 (EIC: YCD)**

DISTRIBUTION STATEMENT A: Approved for public release; distribution is unlimited.

TM 10-7360-208-13&amp;P, 9 September 1991, is changed as follows:

1. Remove and insert pages as indicated below. New or changed text material is indicated by a vertical bar in the margin. An illustration change is indicated by a miniature pointing hand.

## Remove pages

1-5 and 1-6  
2-53 through 2-60  
C-3 and C-4  
C-9 and C-10  
F-17 and F-18  
F-33 and F-34  
F-41 and F-42  
F-45 and F-46  
F-49 and F-50  
F-53 through F-62

## Insert pages

1-5 and 1-6  
2-53 through 2-60  
C-3 and C-4  
C-9 and C-10  
F-17 and F-18  
F-33 and F-34  
F-41 and F-42  
F-45 and F-46  
F-49 and F-50  
F-53 through F-62

2. Retain this sheet in front of manual for reference purposes.

By Order of the Secretary of the Army:

Official:

  
MILTON H. HAMILTON  
Administrative Assistant to the  
Secretary of the Army  
05092

GORDON R. SULLIVAN  
General, United States Army  
Chief of Staff

## DISTRIBUTION:

To be distributed in accordance with DA Form 12-25-E, block no. 5473, requirements for TM 10-7360-208-13&amp;P.





CHANGE

NO. 2

HEADQUARTERS  
DEPARTMENT OF THE ARMY  
WASHINGTON, D.C., 15 January 1993

Operator's, Unit, and Direct Support  
Maintenance Manual Including  
Repair Parts and Special Tools List

**MODULAR FIELD KITCHEN (MFK)**  
**NSN 7360-01-276-9817 (EIC: YCD)**

DISTRIBUTION STATEMENT A: Approved for public release; distribution is unlimited

TM 10-7360-208-13&P, 9 September 1991, is changed as follows:

1. Remove and insert pages as indicated below. New or changed text material is indicated by a vertical bar in the margin. An illustration change is indicated by a miniature pointing hand.

Remove pages

2-11 and 2-12  
C-11 and C-12

Insert pages

2-11 and 2-12  
C-11 and C-12

2. Retain this sheet in front of manual for reference purposes.

Official:



MILTON H. HAMILTON  
*Administrative Assistant to the  
Secretary of the Army*  
03507

GORDON R. SULLIVAN  
*General, United States Army  
Chief of Staff*

**DISTRIBUTION:**

To be distributed in accordance with DA Form 12-25-E, block no. 5473, requirements for TM 10-7360-208-13&P.



CHANGE

NO. 1

HEADQUARTERS  
DEPARTMENT OF THE ARMY  
WASHINGTON D.C., 28 FEBRUARY 1992

Operator's, Unit, and Direct Support  
Maintenance Manual Including  
Repair Parts and Special Tools List  
for

**MODULAR FIELD KITCHEN (MFK)**  
**NSN 7360-01-2769817 (EIC: YCD)**

Approved for public release; Distribution is unlimited

TM 10-7360-208-13&P, 9 September 1991 is changed as follows:

1. Appendix F, Unit and Direct Support Maintenance Including Repair Parts and Special Tools List (RPSTL), Sections II and IV, have been revised to incorporate 100% National Stock Number assignment. Because entire sections are revised, no change bars/hands are used.

Remove pages

F-1/(F-2 blank)

Insert pages

F-1 through F-62

2. Retain this sheet in front of manual for reference purposes.

By Order of the Secretary of the Army:

Official:

  
MILTON H. HAMILTON  
Administrative Assistant to the  
Secretary of the Army  
01156

GORDON R. SULLIVAN  
General, United States Army  
Chief of Staff

**DISTRIBUTION:**

To be distributed in accordance with DA Form 12-25A, Operator, Unit, and Direct Support Maintenance requirements for Kitchen, Field, Mobile, Trailer Mounted (MKT-75).



INSERT LATEST CHANGED PAGES. DESTROY SUPERSEDED PAGES.

**LIST OF EFFECTIVE PAGES**

NOTE: The portion of text affected by the changes is indicated by a vertical line in the outer margins of the page. Changes to illustrations are indicated by shaded or screened areas, or by miniature pointing hands. Zero in the "Change No." column indicates an original page.

Dates of issue for original and changed pages are:

Original ...0...	9 September 1991	Change ...4...	17 January 1995
Change ...1...	28 February 1992	Change ...5...	3 August 1995
Change ...2...	15 January 1993	Change ...6...	10 October 1996
Change ...3...	31 August 1993	Change ...7...	30 September 2005

**TOTAL NUMBER OF PAGES IN THIS PUBLICATION IS 244, CONSISTING OF THE FOLLOWING:**

<b>Page No.</b>	<b>Change No.</b>	<b>Page No.</b>	<b>Change No.</b>	<b>Page No.</b>	<b>Change No.</b>
Title	0	5-3/(5-4 blank)	0	F-23	4
A	4	A-1/(A-2 blank)	6	F-24	0
b	6	B-1 – B-7/(B-8 blank)	7	F-25	4
c/(d blank)	0	C-1	0	F-26	0
i	6	C-2	5	F-27	4
ii – iii/(iv blank)	4	C-3	3	F-28	0
1-1 – 1-3	0	C-4	4	F-29	4
1-4	6	C-5	0	F-30	0
1-5	0	C-6	5	F-31	4
1-6	6	C-7	0	F-32	0
1-7 – 1-8	0	C-8 – C-9	5	F-33	4
1-9/(1-10 blank)	4	C-10	6	F-34	0
2-1 – 2-2	0	C-11	0	F-35	4
2-3 – 2-4	6	C-12	2	F-36	0
2-5 – 2-7	0	C-13 – C-14	0	F-37	4
2-8	6	C-15	5	F-38	0
2-9 – 2-11	0	C-16	0	F-39 – F-40	4
2-12	2	C-17	6	F-41	0
2-13 – 2-20	0	C-18 – C-19	0	F-42	3
2-21	6	C-20	6	F-43 – F-44	0
2-22 – 2-32	0	D-1/(D-2 blank)	0	F-45 – F-46	4
2-33	6	E-1	0	(F-47 blank)/ F-48	0
2-34 – 2-52	0	E-2	6	F-49 – F-50	6
2-53	6	F-1 – F-8	0	F-51/(F-52 blank)	0
2-54	3	F-9	4	F-53 – F-54	4
2-55 – 2-56	4	F-10	0	F-55	6
2-57 – 2-59	3	F-11	5	F-56	4
2-60 – 2-61/(2-62 blank)	0	F-12	0	F-57	6
3-1	0	F-13/(F-14 blank)	4	F-58 – F-62	4
3-2	6	F-15 – F-16	0	G-1 – G-3	0
3-3 – 3-4	0	F-17	4	Index-1 – Index-2	0
4-1 – 4-5	0	F-18	0		
4-6	6	F-19	4		
4-7 – 4-21/(4-22 blank)	0	F-20	0		
5-1	0	F-21	4		
5-2	6	F-22	0		



OPERATOR, UNIT, AND DIRECT  
SUPPORT MAINTENANCE MANUAL INCLUDING  
REPAIR PARTS AND SPECIAL TOOLS LIST

**FOR**  
**MODULAR FIELD KITCHEN (MFK)**  
**NSN 7360-01-276-9817**

DISTRIBUTION STATEMENT A: Approved for public release; distribution is unlimited.

**REPORTING ERRORS AND RECOMMENDING IMPROVEMENTS**

You can help improve this manual. If you find any mistakes, or if you know of away to improve these procedures, please let us know. Mail your letter or DA Form 2028 (Recommended Changes to Publications and Blank Forms), or DA Form 2028-2 located in the back of this manual directly to: Commander, US Army Aviation and Troop Command, ATTN: AMSAT-I-MP, 4300 Goodfellow Blvd., St. Louis, MO 63120-1798. You may also submit your recommended changes by E-mail directly to <mpmt%avma28@st-louis-emh7.army.mil>. A reply will be furnished directly to you. Instructions for sending an electronic 2028 may be found at the back of this manual immediately preceding the hard copy 2028.

Current as of date is 10 December 1993

**TABLE OF CONTENTS**

	Page
<b>CHAPTER 1. <u>INTRODUCTION</u></b>	
Section I. General Information .....	1-4
II. Equipment Description and Data .....	1-5
III. Technical Principles of Operation .....	1-9/(1-10 blank)
<b>CHAPTER 2. <u>OPERATING INSTRUCTIONS</u></b>	
Section I. Description and Use of Operator's Controls and Indicators .....	2-2
II. Operator Preventive Maintenance Checks and Services (PMCS).....	2-3
III. Operation Under Usual Conditions .....	2-8
IV. Operation Under Unusual Conditions .....	2-60
<b>CHAPTER 3. <u>OPERATING MAINTENANCE INSTRUCTIONS</u></b>	
Section I. Lubrication Instructions .....	3-2
II. Operator's Troubleshooting Procedures .....	3-2
III. Operator's Maintenance Procedures .....	3-4
<b>CHAPTER 4. <u>UNIT MAINTENANCE INSTRUCTIONS</u></b>	
Section I. Repair Parts, Special Tools, TMDE, and Support Equipment .....	4-2
II. Service Upon Receipt .....	4-2
III. Unit Preventive Maintenance Checks and Services (PMCS) .....	4-3
IV. Unit Troubleshooting Procedures .....	4-3
V. Unit Maintenance Procedures .....	4-6
VI. Preparation for Storage or Shipment .....	4-21/(4-22 blank)
<b>CHAPTER 5. <u>DIRECT SUPPORT MAINTENANCE INSTRUCTIONS</u></b>	
Section I. General .....	5-2
II. Direct Support Maintenance Procedures .....	5-2

TABLE OF CONTENTS (Continued)

APPENDIX A REFERENCES .....A-1/(A-2 blank)

APPENDIX B MAINTENANCE ALLOCATION CHART .....B-1

APPENDIX C COMPONENTS OF END ITEM AND BASIC ISSUE ITEM LIST ..... C-1

APPENDIX D ADDITIONAL AUTHORIZATION LIST ..... D-1/(D-2 blank)

APPENDIX E EXPENDABLE DURABLE SUPPLIES AND MATERIALS LIST .....E-1

APPENDIX F REPAIR PARTS AND SPECIAL TOOLS LIST .....F-1

Section I. Introduction .....F-1

Section II. Repair Parts List.....F-8

Group 01. TENT .....F- 8

Group 02. LANTERN, GASOLINE  
Lantern, Gasoline..... F-10

Group 03. RACK ASSEMBLY, STORAGE  
Storage Rack Assembly ..... F-12

Group 04. OVEN ASSEMBLY  
Oven Assembly ..... F-15

Groups 05.and 06. RACKS, BURNERS and BASE  
Rasc, Burner and Rack Base..... F-18

Group 07. GRIDDLE ASSEMBLY  
Griddle Assembly ..... F-20

Group 08. STEAM TABLE ASSEMBLY  
Steam Table Assembly ..... F-22

Group 09. HEATER TANK ASSEMBLY  
Heater Tank Assembly ..... F-24

Group 10. COOKING POT CRADLE ASSEMBLY  
Cooking Pot Cradle Assembly ..... F-26

Group 11. BURNER UNIT, M2A  
M2 Burner Unit and Pre-Heater Generator ..... F-28

Group 12. OPENER, CAN, MOUNTED  
Opener, Can, Mounted ..... F-30

Group 13. TABLE, FOLDING LEG  
Table, Folding and Shelf ..... F-32

Group 14. DISPENSER, LIQUID  
Dispenser, Liquid Insulated ..... F-34

Group 15. FOOD, CONTAINER, INSULATED  
Food Container, Insulated ..... F-36

Group 16. STORAGE CABINET  
Storage Cabinet ..... F-38

Group 17. UTENSILS  
Utensils ..... F-40

Group 18. MISCELLANEOUS ASSEMBLIES BAG, DRINKING WATER STORAGE CAN, GASOLINE  
CAN, WATER  
Bag, Drinking Water Storage, Gasoline Can and Water Can ..... F-49



Group 019. BULK  
    Fig. Bulk ..... F-50  
Section III. Special Tools List..... F-51/(F-52 blank)  
Section IV. Cross-Reference Indexes..... F-53

APPENDIX G ILLUSTRATED LIST OF MANUFACTURED ITEMS..... G-1

GLOSSARY.....Glossary 1

INDEX..... Index 1/(Index-2 blank)



CHAPTER 1

INTRODUCTION

	<b>SECTION/PARAGRAPH</b>
General Information .....	I
Scope .....	1-1
Maintenance Forms, and Records.....	1-2
Reporting Equipment Improvement Recommendations (EIR's) .....	1-3
Destruction of Army Material to Prevent Enemy Use.....	1-4
Preparation for Storage or Shipment.....	1-5
Nomenclature/Common Name Cross-Reference List .....	1-6
Equipment Description and Data .....	II
Equipment Characteristics, Capabilities and Features.....	1-7
Location and Description of Major Components .....	1-8
Equipment Data .....	1-9
Technical Principles of Operation.....	III
Oven Assembly.....	1-10
Griddle Assembly.....	1-11
Steam Table Assembly .....	1-12
Heater Tank Assembly.....	1-13
Cooking Pot Cradle Assembly.....	1-14
M2 Burner Units.....	1-16
Food Container and Liquid Dispensers.....	1-17
Tray-Pack Lifter .....	1-18
Tray-Pack Serving Lifter .....	1-19
Sterilizing Water Bag.....	1-20
Tray-Pack .....	1-21

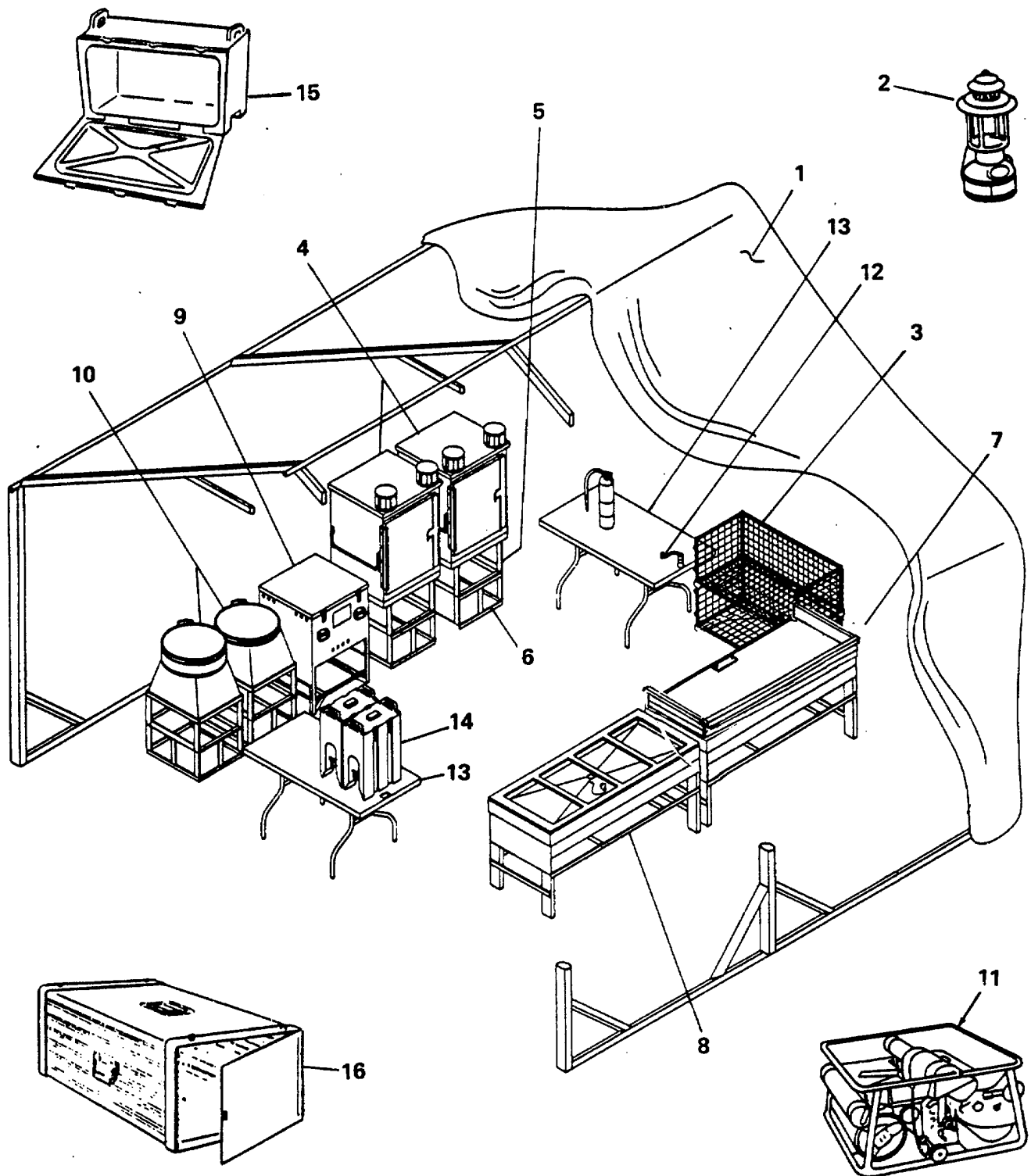

Figure 1-1. Modular Field Kitchen, Major Components (Sheet 1 of 2)

LEGEND

1. TENT
2. LANTERN
3. STORAGE RACK ASSEMBLY
4. OVEN ASSEMBLY
5. BURNER RACK
6. BASE RACK
7. GRIDDLE ASSEMBLY
8. STEAM TABLE ASSEMBLY
9. HEATER TANK ASSEMBLY
10. COOKING POT CRADLE ASSEMBLY
11. M2 BURNER UNIT
12. MOUNTED CAN OPENER
13. WORK TABLE
14. LIQUID DISPENSER
15. FOOD CONTAINER
16. STORAGE CABINET

Figure 1-1. Modular Field Kitchen, Major Components (Sheet 2 of 2)

**Section I. GENERAL INFORMATION****1-1. SCOPE.**

- a. Type of Manual. Operator's, Unit, and Direct Support Maintenance Manual.
- b. Model Number and Equipment Name. Modular Field Kitchen (MFK), NSN 7360-01- 276-9817.
- c. Purpose of Equipment. To provide a responsive, flexible, and mobile way of feeding troop units in the field.
- d. Equipment Requirements.
  - (1) The MFK includes the equipment required by Military Occupational Specialty (MOS) 94B/91 M personnel who are responsible for the feeding of troops in the field.
  - (2) The MFK requires water and gasoline to operate.
  - (3) The tools and ancillary items authorized to the MFK will be used jointly to service and support the MFK and the Food Sanitation Center (FSC).

**1-2. MAINTENANCE FORMS AND RECORDS.** Department of the Army forms and procedures used for equipment maintenance will be those prescribed by DA PAM 738-750, the Army Maintenance Management Systems (TAMMS).

**1-3. REPORTING EQUIPMENT IMPROVEMENT RECOMMENDATIONS (EIR'S).** If your Modular Field Kitchen needs improvement, let us know. Send us an EIR. You, the user, are the only one who can tell us what you don't like about your equipment. Let us know why you don't like the design or performance. Put it on an SF 368 (Quality Deficiency Report). Mail it to us at Commander, U.S. Army Aviation and Troop Command, ATTN: AMSAT-I-MDO, 4300 Goodfellow Blvd., St. Louis, Missouri 63120-1798. We will send you a reply.

**1-4. DESTRUCTION OF ARMY MATERIAL TO PREVENT ENEMY USE.** Refer to TM 750-244-3 for procedures covering the destruction of Army material to prevent enemy use.

**1-5. PREPARATION FOR STORAGE OR SHIPMENT.** Refer to para 4-21 for procedures used to prepare the MFK for storage or shipment.

- a. Administrative Storage.

- (1) Placement of equipment in administrative storage should be for short periods of time when a shortage of maintenance effort exists. Items should be in mission readiness within 24 hours or within the time factors as determined by the directing authority. During the storage period appropriate maintenance records will be kept.

- (2) Before placing equipment in administrative storage, current Preventive Maintenance Checks and Services (PMCS) should be completed, shortcomings and deficiencies should be corrected, and all Modification Work Orders (MWO's) should be applied.

- b. Storage Site Selection. Inside storage is preferred for items selected for administrative storage. If inside storage is not available, trucks, vans, convex containers and other containers may be used.

**1-6. NOMENCLATURE/COMMON NAME CROSS-REFERENCE UST. A cross-reference list of the common names used throughout this manual to the official nomenclature is provided below:**

COMMON NAME	OFFICIAL NOMENCLATURE
Field Kitchen	Kitchen, Field, Modular
Tent	Tent, Extendable, Modular (16 feet x 20 feet Utility)
Lantern	Lantern, Gasoline
Heater Tank	Heater Tank Assembly
M2 Burner Unit	Burner Unit, Gasoline, Model M2/M2A
Work Table	Table, Folding Leg
Liquid Dispenser	Dispenser, Liquid, Insulated
Food Container	Food Container, Insulated
Server Lifter	Lifter, Tray-Pack, Serving
Sanitation Center	Food Sanitation Center (FSC)

**Section II. EQUIPMENT DESCRIPTION AND DATA**

**1-7. EQUIPMENT CHARACTERISTICS, CAPABILITIES, AND FEATURES.**

Characteristics, capabilities, and features of the Modular Field Kitchen include:

- a. Characteristics.
  - (1) Used with the Food Sanitation Center (FSC).
  - (2) Used in basic, hot, and cold climate conditions.
- b. Capabilities.
  - (1) To prepare A-, B-, and T-ration foods.
  - (2) To provide hot water for heating T-ration foods and beverages.
  - (3) To transport A-, B-, and T-ration foods and beverages.
  - (4) Provides pots, pans and utensils.
  - (5) Protects food preparation and serving areas from weather.
  - (6) One MFK with assigned personnel can serve three hot meals a day for 250 troops on a sustaining basis.
  - (7) Two MFK's may be combined to double capacity.
- c. Features.
  - (1) Sets-up on-site in 60-minutes by four soldiers upon arrival.
  - (2) Break-down for movement in 60-minutes by four soldiers after meals.
  - (3) M2 burner unit used for heat source.
  - (4) Day and night operation.
  - (5) Transported on 5-ton tactical cargo vehicle, or 2-1/2 ton tactical cargo vehicle.
  - (6) Insulated containers provide beverages and tray-pack foods to dispersed squad-size troops.

**1-8. LOCATION AND DESCRIPTION OF MAJOR COMPONENTS (Figure 1-1.)**

TENT (1) Contains all MFK equipment and protects personnel from weather.

LANTERN (2) Three gasoline lanterns used for night operations.

STORAGE RACK ASSEMBLY (3) One storage rack assembly set (each set formed by stacking three rack assemblies).

OVEN ASSEMBLY (4) Two oven assemblies permit food cooking/heating, roasting and baking and maintaining serving temperatures of hot foods.

BURNER RACK (5) Two burner racks support the M2 burners under the oven assemblies.

BASE RACK (6) Two base racks support the burner racks and oven assemblies.

GRIDDLE ASSEMBLY (7) One griddle assembly used for grilling food. Uses two M2 burner units. It consists of one griddle top, double burner rack and double base rack  
 STEAM TABLE ASSEMBLY (8) One steam table assembly used with two M2 burner units to maintain temperature of hot items on serving line. It consists of adapter top, steam table body, double burner rack and double base rack.

HEATER TANK ASSEMBLY (9) One heater tank assembly with one M2 burner unit in place and filled with water, heats tray-packs.

COOKING POT CRADLE ASSEMBLY (10) Two cooking pot cradle assemblies with M2 burner units in place permit the preparation of hot beverages.

M2 BURNER UNIT (11) Six M2 burner units are used as a heat source for the MFK equipment.

MOUNTED CAN OPENER (12) For opening tray-packs. Two are supplied and are mounted on the work tables.

WORK TABLE (13) Two work tables are used for various food preparation activities.

LIQUID DISPENSER (14) Seventeen liquid dispensers maintain beverages hot or cold for on-site and remote feeding.

FOOD CONTAINER (15) Six food containers maintain heated food for both remote and on-site feeding.

STORAGE CABINET (16) Two storage cabinets are used to store and maintain pastry/dessert type items.

**1-8.1 DIFFERENCES IN EQUIPMENT.**

Original production MFK ovens were built with gaskets around the oven door. If the gaskets need to be replaced, follow the procedures for repair of the oven door assembly in Chapter 4. Later production ovens were designed and built without oven door gaskets.

**1-9. EQUIPMENT DATA.**

a. Capabilities.

(1) TENT

- (a) Frame supported, 16 feet x 20 feet
- (b) Provided with doorways on each side
- (c) Screened roof vents with flaps
- (d) Windows on each side
- (e) One stove pipe opening in roof
- (f) Equipped with cotton liner for cold weather operations.
- (g) Provided with tent fly to minimize the solar load in hot environments, and to permit the roof vents to be opened in bad weather.
- (h) Can be expanded in 8-foot sections to form a shelter of any length.
- (i) Refer to TM 10-8340-224-13 for additional tent data.



**1-9. EQUIPMENT DATA (CONT).**

- (2) LANTERN
  - (a) Provides artificial light.
  - (b) Refer to FM 10-23 for lantern data.
  
- (3) STORAGE RACK ASSEMBLY
  - (a) Used to hold, store or dry items (pots, pans, etc.) until next required use.
  - (b) Used as a shipping container for nested smaller items.
  - (c) One side removable and can be used as a shelf when used as a storage rack.
  - (d) Three storage rack assemblies combined, form a set.
  
- (4) OVEN ASSEMBLY, GRIDDLE ASSEMBLY, STEAM TABLE ASSEMBLY
  - Permits food cooking, heating, roasting, baking, grilling and maintaining serving temperatures of hot foods.
  
- (5) HEATER TANK ASSEMBLY
  - (a) Heats up to 20 tray-packs submerged in hot water.
  - (b) Heats 150 T-ration meals, to at least 165°F (74°C) within 2 hours after arrival on site.
  
- (6) COOKING POT CRADLE ASSEMBLY
  - Heats liquids for cooking foods and heating beverages.
  
- (7) M2 BURNER UNIT
  - (a) Burns fuel at rate of 0.5 gallons (1.9 liters) per hour; produces approximately 60,000 BTU/hour.
  - (b) Refer to TM 10-7360-204-13&P for additional M2 burner unit data.
  
- (8) WORK TABLE
  - Used for food preparation, serving-line counter space.
  
- (9) LIQUID DISPENSER
  - (a) For on-site or remote feeding.
  - (b) Five gallon capacity.
  - (c) Maintains hot or cold beverages.
  - (d) Maintains beverage temperature of no less than 140°F (60°C) for up to 4 hours in temperatures as low as -25°F (-32°C).
  
- (10) FOOD CONTAINER
  - (a) For on-site or remote feeding for up to 24 troops.
  - (b) With pans with covers for A/B type rations it can transport and/or maintain hot A-, B-, or T-rations.
  - (c) Maintains heated food at no less than 140°F (60°C) for up to 4 hours.
  
- (11) STORAGE CABINET
  - (a) To store and maintain pastry/desert type items.
  - (b) Holds six (19 by 22 inch; 48.26 by 55.88 cm) shelf pans or 150 servings of pastry items.
  
- (12) ADDITIONAL KITCHEN COMPONENTS
  - (a) Consist of gasoline/water cans, preparation and serving utensils and other equipment items required for food preparation and serving purposes.
  - (b) See Appendix C for illustrations.

**1-9. EQUIPMENT DATA (CONT).**

b. Specifications. Dimensions and weights for MFK equipment and accessories are listed in Table 1-1.

**Table 1-1. MFK Major Components, Dimensions, and Weights**

Component	Height		Width		Depth		Weight	
	in.	mm	in.	mm	in.	mm	lb.	kg
Storage Rack Assembly	19.0	483.0	48.0	1219.0	24.0	610.0	43.9	19.9
Oven Assembly	35.5	902.0	25.6	651.0	31.4	798.0	109.5	49.7
Burner Rack	14.9	380.0	20.6	525.0	23.9	607.0	16.4	7.4
Base Rack	11.2	285.0	23.8	605.0	25.0	635.0	9.3	4.2
Griddle Top	4.2	107.7	47.0	1195.0	25.1	639.0	80.9	36.7
Steam Table Body	4.2	107.7	54.1	1375.0	23.6	600.0	61.1	27.7
Double Burner Rack Assembly	18.5	469.9	55.7	1416.0	25.5	647.7	40.0	18.1
Double Base Rack Assembly	18.2	463.5	54.0	1371.6	23.5	596.9	70.0	31.7
Heater Tank Assembly	37.0	940.0	26.6	673.0	26.6	676.0	85.0	38.6
Cooking Pot Cradle Assembly	35.0	889.0	24.7	629.0	23.5	597.0	43.3	19.6
M2 Burner Unit	9.6	246.0	18.7	476.0	23.0	584.0	43.2	19.6
Work Table	37.0	939.8	56.0	1422.4	26.0	660.4	57.4	26.0
Liquid Dispenser	24.4	620.0	9.0	230.0	16.7	425.0	15.0	6.8
Food Container	26.5	673.0	20.7	527.0	16.2	413.0	31.0	14.0
Storage Cabinet	15.0	380.5	18.5	469.9	24.0	610.0	24.0	10.9

### Section III. TECHNICAL PRINCIPLES OF OPERATION

**1-10. OVEN ASSEMBLY.** The oven is an insulated cabinet which retains heat produced by the M2 burner unit. It consists of an oven door, two exhaust vents, and side carrying handles. Oven racks support cooking utensils inside oven.

**1-11. GRIDDLE ASSEMBLY.** The griddle top is mounted on double burner rack which is mounted on the base rack. The griddle uses two M2 burners for heating. It includes splash guards on three sides and adjustable heat guards. The griddle has an anodized protective coating applied during manufacture. To extend griddle serviceability both the top and bottom surfaces can be used for grilling foods. A grease chute and grease slot plug enables the operator to safely remove unwanted grease and food particles from the griddle.

**1-12. STEAM TABLE ASSEMBLY.** The steam table also uses two M2 burner units. The M2 burner units are installed on racks similar to the griddle assembly. A steam table adapter supports tray-packs and steam table pans above the heated water. A plug on the steam table body enables the drainage of water.

**1-13. HEATER TANK ASSEMBLY.** The tank is filled with twenty gallons (75.7 liters) of water and 20 tray-packs. The M2 burner heats the water which brings the tray-packs to a consumable temperature of 165°F (74°C).

**1-14. COOKING POT CRADLE ASSEMBLY.** Liquids for cooking foods and hot beverages are prepared in this unit. Another M2 burner provides the heat needed for the water.

**1-15. M2 BURNER UNITS.** The M2 burner units use gasoline that is pressurized by a hand pump. The pressurized fuel is filtered through a hot generator. The hot generator changes the fuel into a vapor. The vapor is ignited to produce heat.

**1-16. WORK TABLE.** The work tables are used to mount the can openers to open tray-packs and round cans. The tables are also used for food preparation and serving.

**1-17. FOOD CONTAINER AND LIQUID DISPENSERS.** Both the food container and liquid dispensers have been designed to maintain consumption temperatures of 140°F (60°C) for up to 4 hours. Food and beverage are provided to a remote unit of 24 personnel in these units.

**1-18. TRAY-PACK LIFTER.** To ensure that operating personnel are not burned when extracting tray-packs from the heater tank, a lifter is provided.

**1-19. TRAY-PACK SERVING LIFTER.** Once the tray-pack has been removed, it is moved to the worktable by a serving lifter.

**1-20. STERILIZING WATER BAG.** In field operations, water bags are used to store and dispense treated water. A water-purification bag should be set up so that it has good drainage and overhead protection. The bag may be suspended from the limb of a tree or pole mounted horizontally, or it may be supported by poles tied at the top to form a tripod. A small sump pit will keep water from puddling beneath the bag.

**1-21. TRAY-PACKS.** Tray-packs are hermetically sealed, half-size steam table containers in which about 105 ounces (3 kilograms) of food (10 to 25 servings) have been thermally processed. The tray-packs can be transported and stored without refrigeration until needed. Tray-packs have a shelf life of at least 3 years when stored in a cool, dry area at 70°F (23°C). The contents can be heated in and served from the tray-packs. Due to the possibility of flavor loss or damage to the tray-pack, tray-packs should be reheated only twice.



CHAPTER 2

OPERATING INSTRUCTIONS

	SECTION/PARAGRAPH
Description and Use of Operator's Controls and Indicators.....	I
General .....	2-1
Controls and Indicators.....	2-2
Operator's Preventive Maintenance Checks and Services (PMCS).....	II
PMCS Introduction .....	2-3
PMCS Procedures.....	2-3b
Operation Under Usual Conditions.....	III
General .....	2-4
Site Selection .....	2-5
Assembly and Preparation for Use.....	2-6
Operating Procedures.....	2-7
Disassembly and Preparation for Movement.....	2-8
Packaging .....	2-9
Operation Under Unusual Conditions.....	IV
General .....	2-10
Operation in Extreme Cold .....	2-11
Operation Under Rainy or Humid Conditions .....	2-12
Operation in Salt Water Areas .....	2-13
Operation at High Altitudes.....	2-14
Operation in Windy Conditions .....	2-15
Operation in Extreme Heat .....	2-16
Operation in Dusty or Sandy Areas.....	2-17

**Section I. DESCRIPTION AND USE OF OPERATOR'S CONTROLS AND INDICATORS**

**2-1. GENERAL.** The MFK has been designed for use in forward combat areas and has few moving parts, with the exception of the M2 burner unit, which is the heat source for food service equipment. MFK components have no electrical controls and indicators.

**2-2. CONTROLS AND INDICATORS.**

**CAUTION**

Do not overtighten the drain knob when turning clockwise to close the drain. Overtightening can damage the drain valve.

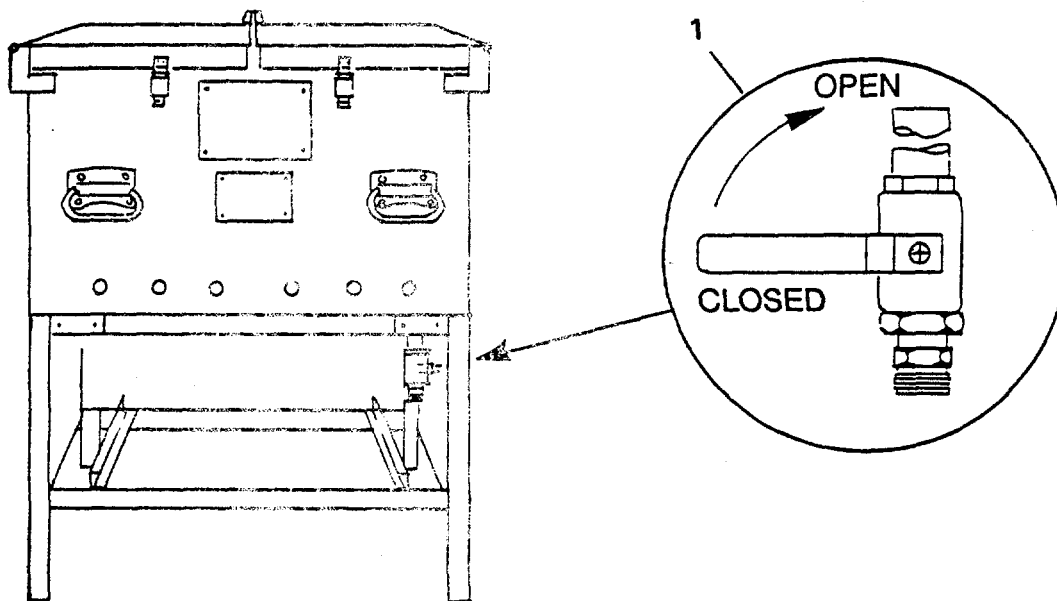

**Table 2-1. Controls and indicators**

KEY	COMPONENT/ ASSEMBLY	CONTROL INDICATOR	FUNCTION
1	HEATER TANK ASSEMBLY	Drain Valve	For draining tank.

Section II. OPERATOR'S PREVENTIVE MAINTENANCE CHECKS AND SERVICES (PMCS)

**2-3. PMCS INTRODUCTION.** Operator preventive maintenance checks and services are to be done to be sure the equipment is ready to use at all times. PMCS helps you find and fix defects before the equipment is damaged or fails.

a. General.

(1) Before you operate, always keep in mind the WARNINGS and CAUTIONS. Perform your before (B) PMCS prior to the equipment performing its intended mission.

(2) While you operate always keep in mind the WARNINGS and CAUTIONS. Perform your during (D) PMCS when the equipment is being used in its intended mission.

(3) After you operate, be sure to perform your after (A) PMCS after the equipment has been taken out of its mission mode.

(4) If your equipment fails to operate, troubleshoot with proper equipment. Report any deficiencies using DA Form 2404. Equipment inspection and maintenance worksheet. See DA PAM 738-750.

b. PMCS Procedures.

(1) The purpose of the PMCS table is to indicate the order in which checks are to be done, as well as to indicate when they are to be done.

(2) The first column of the table provides the item number (order) for accomplishment of checks and services. Column two (interval) provides when they are to be done. Application intervals are before (B), during (D), and after (A) use.

(3) The "Equipment is Not Ready/Available If" column contains the criteria that will cause the equipment to be classified as not ready/available because of inability to perform its combat mission.

(4) Report deficiencies in accordance with DA PAM 738-750. Correct deficiencies in accordance with the "Procedures/Check for and have Repaired or Adjust as Necessary" column and troubleshooting procedures contained in Table 3-1.

(5) Perform PMCS for the tent in accordance with TM 10-8340-224-13.

(6) Perform PMCS on the M2 burner units in accordance with TM 10-7360-204-13&P.

**NOTE**

**Use Table 2-2. item number column to get the numbers for the "TM Item Number" column of DA Form 2404, Equipment Inspection and Maintenance Worksheet in recording results of your PMCS.**

**Table 2-2. Operator's Preventive Maintenance Checks and Services**  
**B- BEFORE OPERATION D- DURING OPERATION A- AFTER OPERATION**

ITEM NO.	INTERVAL			ITEM TO BE INSPECTED	PROCEDURES Check for and have repaired or adjusted as necessary	EQUIPMENT IS NOT READY/ AVAILABLE IF
	B	D	A			
1	•		•	Tent	Perform PMCS IAW TM 10-8340-224-13. Check for leaks, dents, broken glass and safety of operation. Inspect for damaged frame or front cover. Check that rack units stack properly. Check wire mesh for bends, breaks or broken welds at the tabs. Check that front cover/shelf is not warped. Inspect oven assembly for broken, loose or missing hardware, warning decal or components, bent members or broken welds. Check door for damage, and ensure it closes tightly. Check for missing or damaged oven racks. Inspect for bent members or broken welds. Inspect for bent members or broken welds. Check for warped or missing griddle assembly, grease slot plug, steam table drain plug, or griddle splash guards. Check heat guards for adjustability. Check for badly scratched or worn off anodized coating on griddle (over 50% on both surfaces). Refer to item 5 for racks. Ensure that warning plates are properly mounted and legible.	Door damaged lets heat escape from oven; or bent oven racks don't hold food containers.  Bent or broken welds which prevent M2 burner unit being used properly. Griddle assembly is physically damaged. Parts are missing or loose. Warning plate is missing or illegible.
2	•		Lantern			
3	•		Storage Rack Assembly			
4			Oven Assembly			
5	•		Burner Rack and Base Rack			
6	•		Griddle Assembly and Steam Table Assembly			

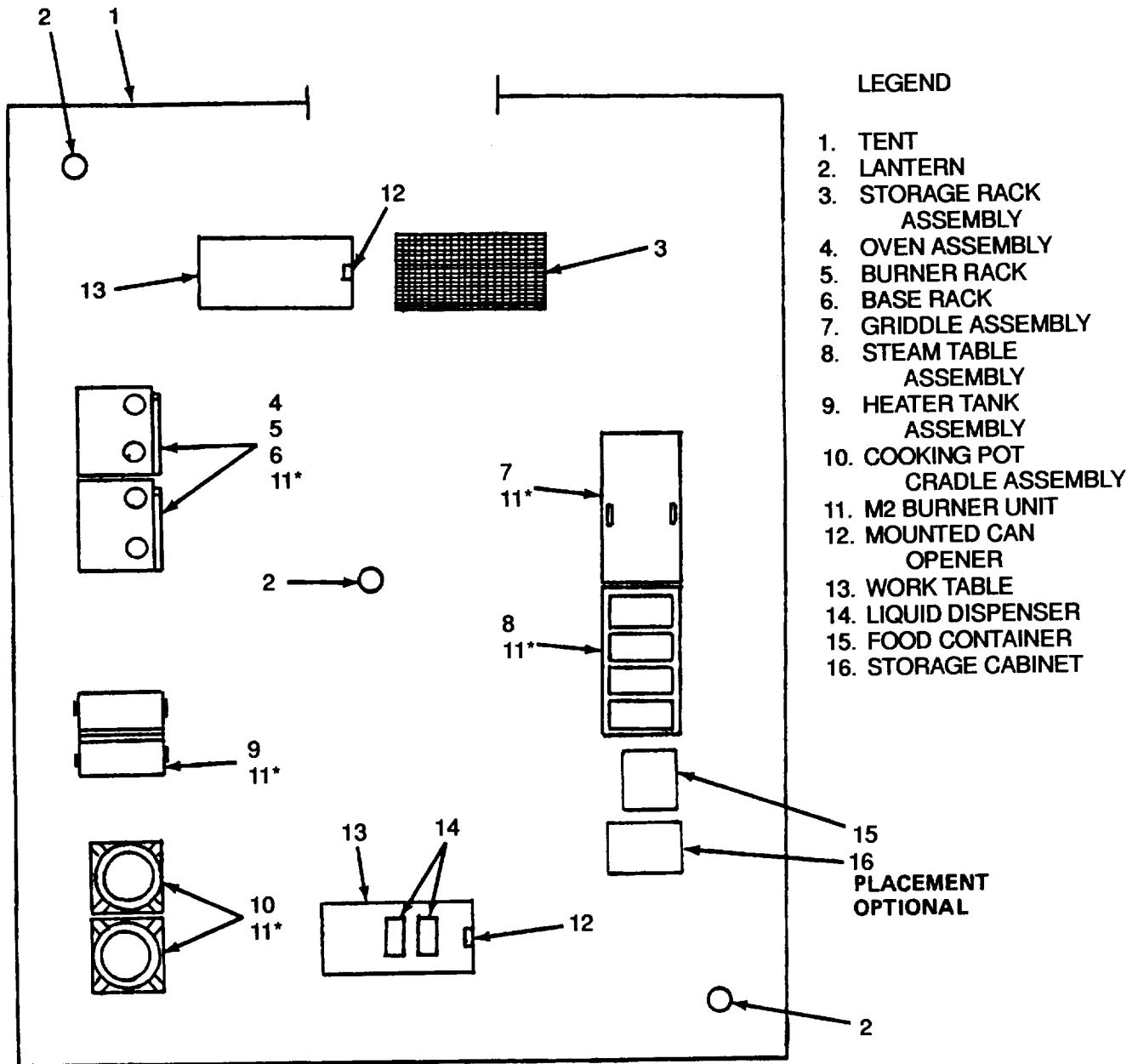

Table 2-2. Operator's Preventive Maintenance Checks and Services

ITEM NO.	B-Before Operation			D-During Operation	A-After Operation	
	INTERVAL			Item To Be Inspected	Procedures	Equipment Not Ready/Available If:
	B	D	A			
7	•			Heater Tank Assembly	Inspect heater tank assembly for broken, loose or missing hardware, bent members, broken welds and leaking drain valve. Check that warning and instruction plates are properly mounted and legible.	Heater cabinet is physically damaged or leaks. Water drain valve leaks. Warning plate missing or illegible.
8	•			Cooking Pot Cradle Assembly	Inspect the cooking pot cradle assembly for bent members, or broken welds. Check that warning plate is properly mounted and legible. Refer to item 5 for racks.	
9	•			M2 Burner Unit	Perform PMCS IAW TM 10-7360-204-13&P.	
10	•			Mounted Can Opener	Check mounted can opener for operation, damage, and dull blades.	
11	•			Work Table	Check to ensure tables are level and secure. Check for broken welds, loose or missing hardware.	
12	•			Liquid Dispenser	Inspect liquid dispenser for damage or missing hardware. Check for leaks. Inspect operation of faucet assembly, spout assembly, cap vent and lid assembly. Insure gasket on lid assembly forms a good seal.	
13	•			Food Container	Check for damage to gasket, latches and hinges. Check door for proper closing.	
14	•			Storage Cabinet	Inspect for dents, holes and broken welds or damaged frame. Inspect recessed doors for proper opening and closing. Check handles for firmness. Check that catch holds door firmly.	

Table 2-2. Operator's Preventive Maintenance Checks and Services

ITEM NO.	B-Before Operation			D-During Operation	A-After Operation	
	INTERVAL			Item To Be Inspected	Procedures	Equipment Not Ready/Available If:
	B	D	A			
15	•			Utensils	Check all utensils are available. Refer to Appendix C, Components End Item Ust. Inspect for bent, broken or damaged utensils.	
16	•			Gasoline/Water Can	Check for leaks, missing caps or gaskets.	
17	•			Fire Extinguisher	Check to ensure charge reading is in the green and that the seal is not broken. reading in the red.	Fire extinguisher or seal is missing or broken, or charge is
18	•			First Aid Kit	Inventory contents and replace missing or expired items. Consult medical specialist for guidance as required. expired.	Kit is missing, incomplete, or item's kit life has



\* M2 BURNER UNIT USED WHERE NEEDED

Figure 2-1. Basic Operational Configuration.

**Section III. OPERATION UNDER USUAL CONDITIONS****2-4. GENERAL.**

- a. The instructions in this section are for personnel who operate the MFK. Refer to TM 10-8340-224-13 for tent instructions. Refer to FM 10-23 for lantern instructions. Refer to TM 10-7360-204-13&P for M2 burner unit instructions.
- b. The basic operational configuration for the MFK is Shown in Figure 2-1.
- c. All equipment required for this configuration arrives in one truck packed as specified in FM 10-23.
- d. The MFK equipment is packaged in the transport mode in accordance with paragraph 2-9

**WARNING**

**Serious injury could occur if heavy equipment is moved/lifted with- out sufficient personnel to do the job. Use proper physical lifting procedures or use a suitable lifting device or dolly. Wear safety shoes, gloves and other suitable protective clothing.**

- e. MFK major components in the packaged configuration weigh up to 245 pounds. Ensure adequate personnel are used to offload and carry the equipment to the operational site.

**2-5. SITE SELECTION.****WARNING**

**To prevent fires do not use flammable material as a base for the MFK. Fire may cause injury to personnel or damage the equipment.**

- a. Choose a site clear of large rocks and trees with firm ground and good water drainage.
- b. Approximately 600 square feet (56 square meters) is needed to set-up the MFK tent.
- c. If possible, avoid dusty or sandy conditions.
- d. Use gravel or other suitable material for base where ground is wet.
- e. An additional 600 square feet (56 square meters) is needed for the FSC if used with the MFK.

**2-6. ASSEMBLY AND PREPARATION FOR USE.**

- a. Preparation procedures.

(1) Remove all items that were packaged in the major components of the MFK and place them in a convenient location.

- (2) Refer to TM 10-8340-224-13 for set-up of tent and FM-10-23 for lantern instructions.

**2-6. ASSEMBLY AND PREPARATION FOR USE (CONT).**

**WARNING**

- Do not hang fire extinguisher where you would have to walk through a possible fire to reach it.
- Do not hang the fire extinguisher in an extremely hot or cold location. (Check unit name plate for exact temperature limitations). Never throw it in a fire as it could explode.

(3) Hang the fire extinguisher in an accessible location with the top 3-1/2 to 5 feet (1.25 to 1.75 meters) above the floor near an exit.

**WARNING**

The gasoline lantern must be suspended from a frame member of the tent. Allow a minimum of 12 inches (305 mm) between the top of the lantern and the tent liner or fabric. (See TM 10-8340-224-13&P). Place lanterns so that they will not be knocked down by, or cause injury to personnel walking through the tent.

(4) For night operation place the lantern in a convenient location as follows:

(a) In the area selected for the lantern, locate a position in the tent where a header and an arch are secured together.

(b) Allow a minimum of 12 inches (305 mm) between the top of the lantern and liner or fabric, and secure the lantern to the header.

(c) When the lantern is not required, turn it off and let it cool down.

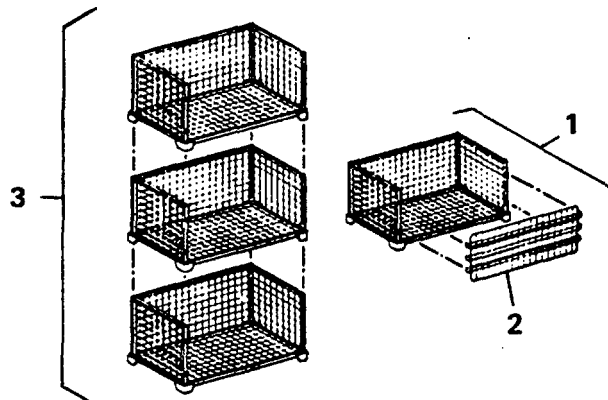

b. Storage Rack Assembly. The storage rack assembly (1) may be used as a single rack unit with a front cover (2) or as a set (3) stacked in two or three units with the front cover (2) used as a shelf piece.

**2-6. ASSEMBLY AND PREPARATION FOR USE (CONT).**

c. Oven Assembly. Assemble each oven assembly (1) as follows:

**WARNING**

Serious injury could occur if heavy equipment is moved/lifted without sufficient personnel to do the job. Use proper physical lifting procedures or use a suitable lifting device or dolly. Wear safety shoes, gloves and other suitable protective clothing.

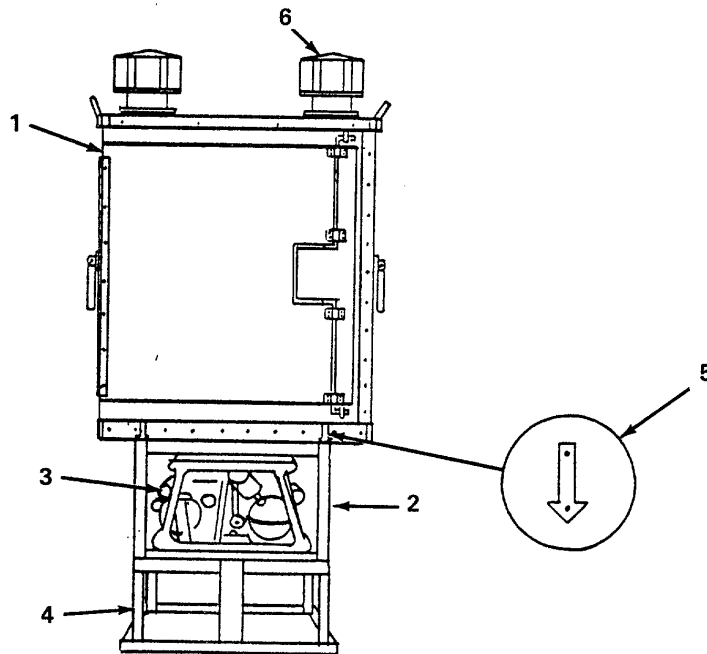

(1) Move each oven assembly (1), burner rack (2) with M2 burner unit (3) installed and base rack (4) to the oven assembly location (Figure 2-1).

(2) Place the base rack (4) in position; place the M2 burner unit (3) installed in its burner rack (2), on top of the base rack (4), note the arrow markings (5) on the oven assembly (1) and place the oven assembly (1) on top of the burner rack (2).

(3) Place two vent caps (6) in the openings on top of the oven assembly (1).

## 2-6. ASSEMBLY AND PREPARATION FOR USE (CONT).

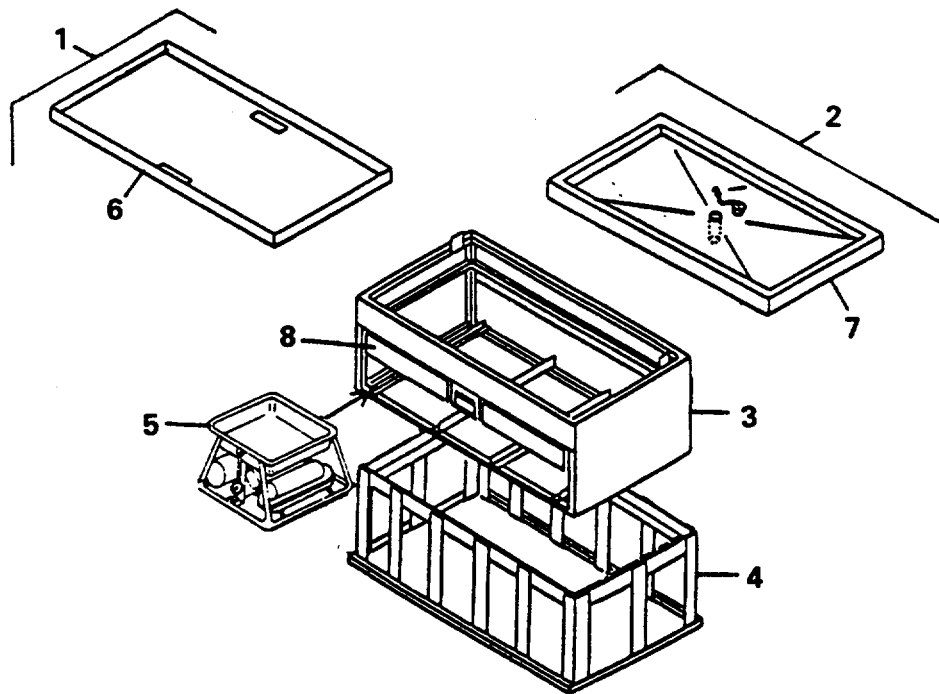

d. Griddle Assembly (1) and Steam Table Assembly (2). The double burner rack (3) and the double base rack (4) in the griddle assembly (1) are identical to the racks in the steam table assembly (2). Proceed to assemble the griddle assembly (1) or the steam table assembly (2).

**WARNING**

Serious injury could occur if heavy equipment is moved/lifted without sufficient personnel to do the job. Use proper physical lifting procedures or use a suitable lifting device or dolly. Wear safety shoes, gloves and other suitable protective clothing.

(1) In turn, move the double base rack assembly, the double burner rack assembly, two burner units, and the griddle, or steam table assembly to the location shown in Figure 2-1.

(2) Place the double burner rack (3) onto the double base rack (4) so that the burner units (5) can be slid into the rack from the operator's side. The heat guards (8) face the operator.

**NOTE**

M2 burner units may be already installed if packaged from previous preparation for movement.

(3) Raise heat guards (8). If not installed, slide M2 burner units (5) into the double burner rack (3).

**NOTE**

Either surface of the griddle can be installed in the operating position.

(4) Place the griddle (6) or steam table body (7) onto the double burner rack (3).

2-6. ASSEMBLY AND PREPARATION FOR USE (CONT).

e. Griddle Top and Grease Chute.

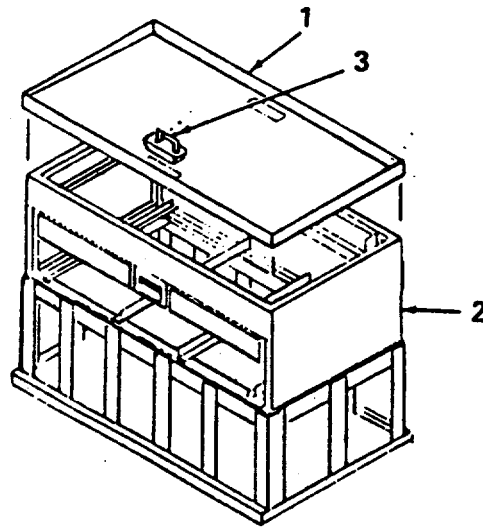

(1) Place the griddle top (1) on the double burner rack (2) with the grease slot plug (3) in place.

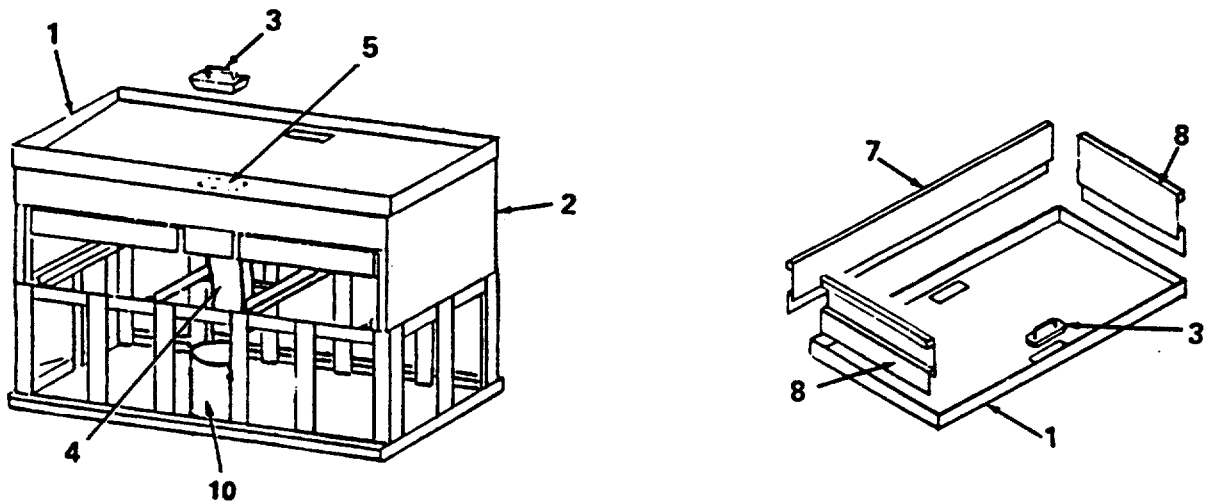

(2) Connect the grease chute (4) to the grease slot (5) in the griddle top (1) so that it leads through the center member of the double burner rack (2). Make sure the top of the grease chute (4) mates with the grease chute slot (5) in the griddle (1).

(3) Place an empty #10 can (6) at the bottom of the grease chute (4) to collect grease.

(4) Place the long splash guard (7) on the griddle top (1) opposite the grease slot plug (3). Place the two short splash guards (8) on the sides.



2-6. ASSEMBLY AND PREPARATION FOR USE (CONT).

f. Steam Table Body.

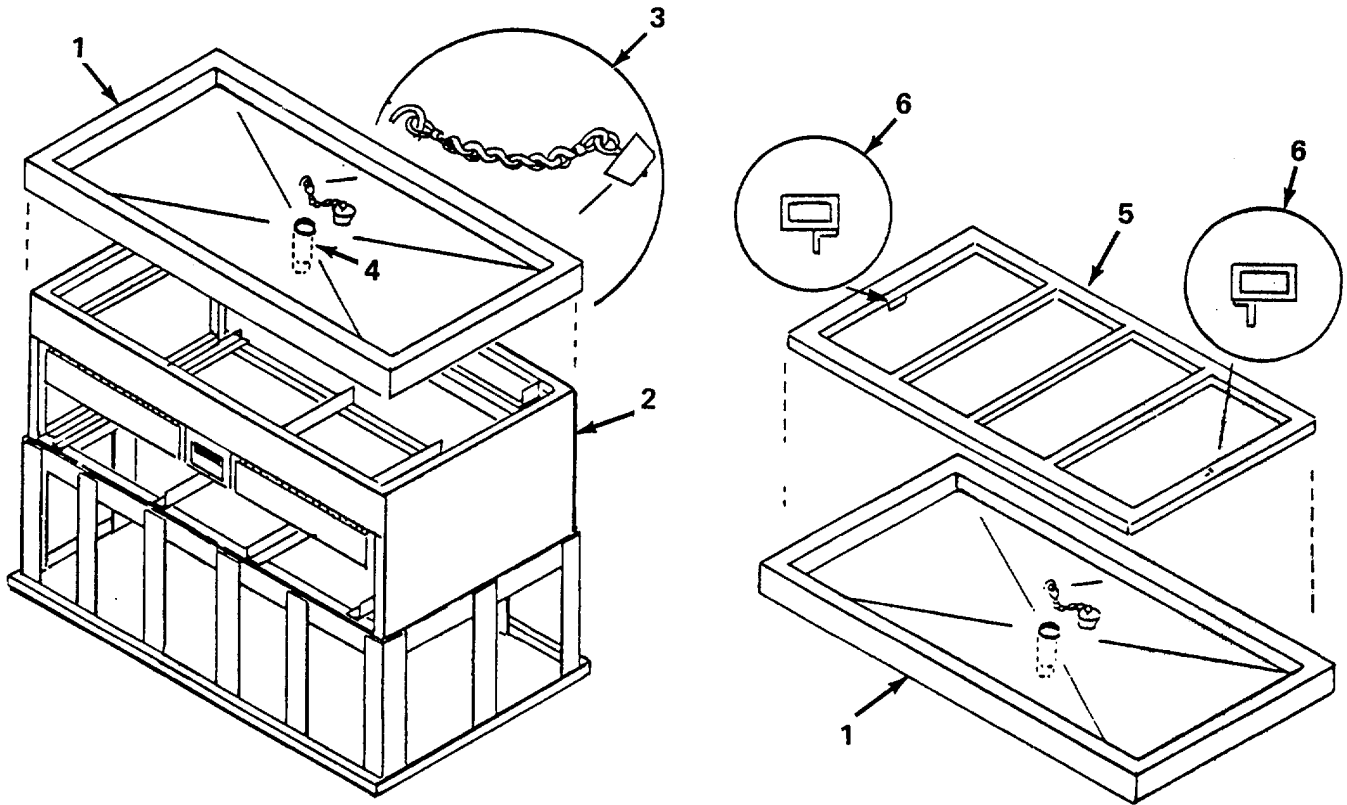

Assemble the steam table body (1) with the steam table adapter (5) to fit over the double burner rack (2). The stopper (3) faces up and the water drain (4) faces down. Make sure the braces (6) fit inside the steam table body assembly (1).

2-6. ASSEMBLY AND PREPARATION FOR USE (CONT).

g. Heater Tank Assembly.

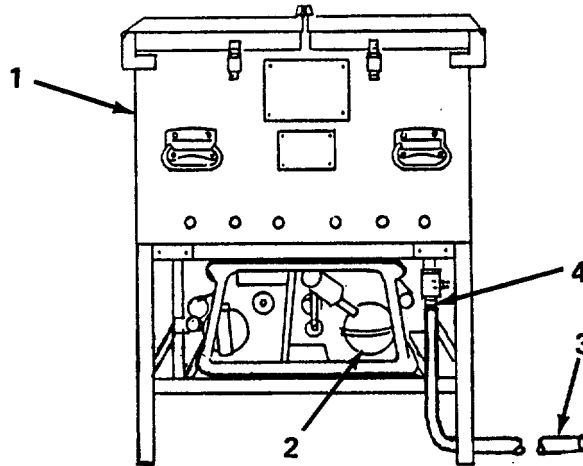

- (1) Move the heater tank assembly (1) to the correct location (Figure 2-1).
- (2) If removed, install the M2 burner unit (2) by sliding the M2 burner unit in the burner rack.
- (3) Remove accessories from inside tank if packed from previous location.
- (4) Connect the drain hose (3) to the pipe-to-hose adapter (4).
- (5) Locate free end of drain hose (3) away from MFK to suitable drainage location.

h. Cooking Pot Cradle Assembly.

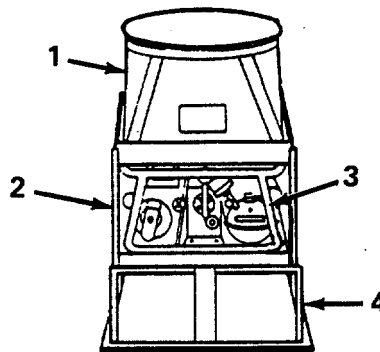

- (1) Move the cooking pot cradle (1), a burner rack (2), M2 burner unit (3), and base rack (4) to the correct location. (Figure 2-1)
- (2) Place the base rack (4) in position; install the M2 burner unit (3) in the burner rack (2) and the cooking pot cradle (1) on the burner rack (2).

**2-6. ASSEMBLY AND PREPARATION FOR USE (CONT)**

- i. Burner Units. Prepare the burner units in accordance with TM 10-7360-204-13&P.

**WARNING**

Leave enough air space between the tent wall and the food service equipment. Frequently check for heating of the tent wall while the M2 burner units are in use. Move the M2 burner units further away from the tent wall if necessary. If they are too close to the tent wall, they could ignite the tent.

**NOTE**

There is space for nine burner units under the food equipment as follows: two M2 burner units in each of the griddle assembly, oven assembly, cooking pot assembly, steam table assembly, and one M2 burner in the heater tank assembly.

Only six burner units are furnished with the MFK. The location of the burner unit will be based on current need as determined by senior food service personnel. Location will change as required.

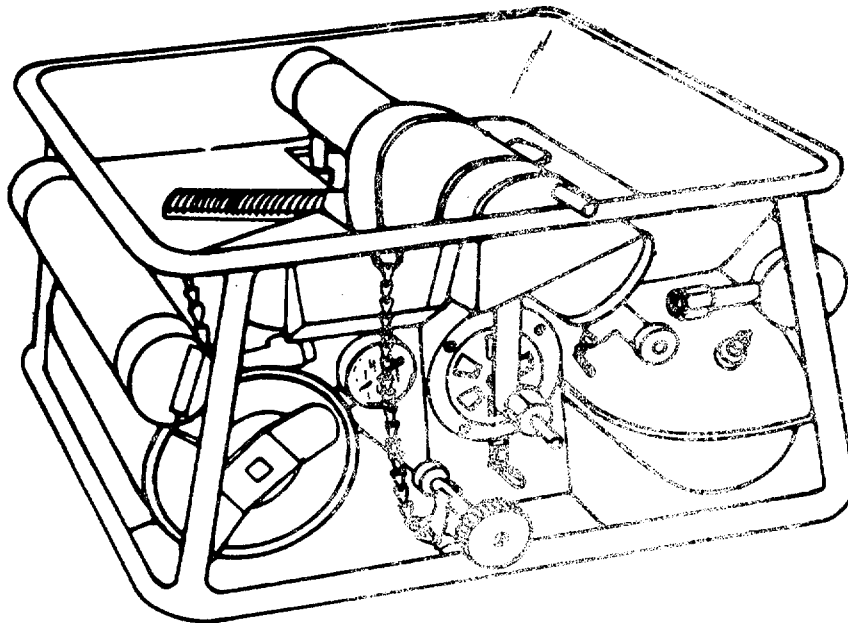

**2-6. ASSEMBLY AND PREPARATION FOR USE (CONT).**

j. Mounted Can Opener, Work Table and Shelf.

(1) Pull out the leg assemblies (1) until the linkage (2) snaps into place in the fully extended position.

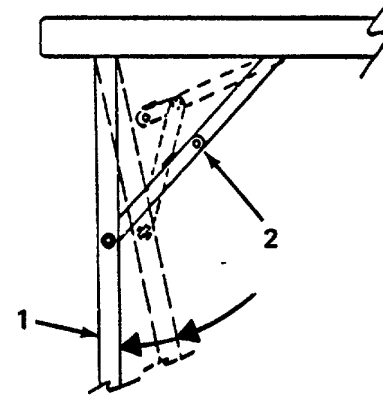

(2) Place the shelf (3) so that the end lips (4) rest on the crossbars (5) connecting the legs (6) at each end.

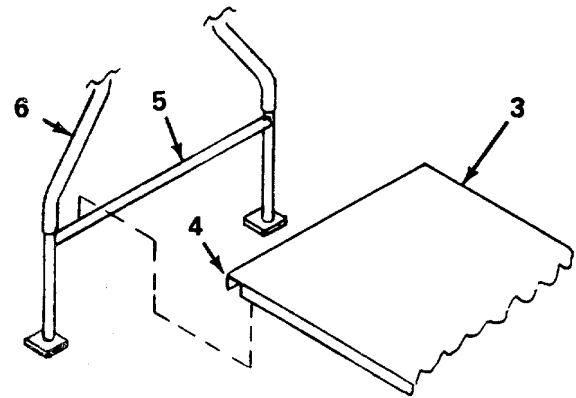

(3) Take the two work tables to their operating locations as shown in (Figure 2-1).

(4) Mount the can openers (7) in the can opener slot on the work tables.

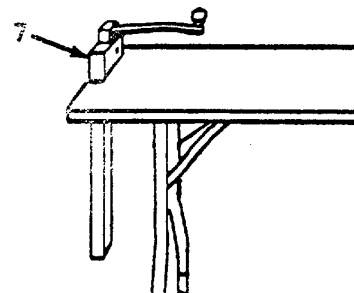

## 2-6. ASSEMBLY AND PREPARATION FOR USE (CONT).

### j. Mounted Can Opener. Work Table and Shelf (Cont).

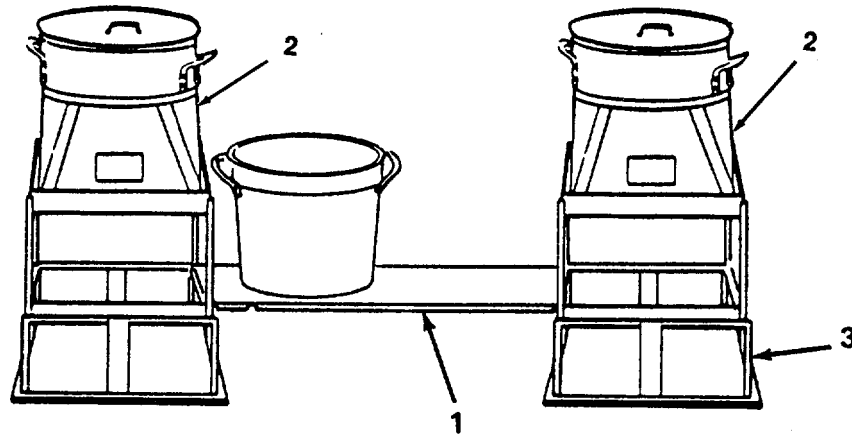

(5) The work table shelf (1) can also be used to form a pot staging area between two cooking pot cradle assemblies (2) as shown above. Used in this location, the shelf lips are fitted over the top base rack side bars (3).

### k. Optional Configurations.

(1) General. When it is required to feed approximately 750 persons, it will be necessary to combine two or three MFK's. Figure 2-2 shows consolidation of equipment from two MFK's in a 48 x 20 foot (14.64 x 6.1 meters) tent. To sanitize the pots, pans and utensils used with three MFK's, two FSCs must be combined. For information on combining two FSCs, refer to TM 10-7360-211-13&P. To operate in the consolidated configurations, the site must be large enough to accommodate the 48 x 20 foot (14.64 x 6.1 meters) MFK area and the 32 x 20 foot (9.8 x 6.1 meters) FSC area.

**2-6. ASSEMBLY AND PREPARATION FOR USE (CONT).**

(2) Two MFK's consolidated. When two MFK's are consolidated and used with two FSC's, the equipment is packed, transported, and unloaded from four 2 1/2 ton or 5-ton tactical vehicles, or two vehicles with 1 1/2 ton cargo trailers as described in FM 10-23. To operate in the consolidated configuration, the following MFK major components are required:

- (a) One tent, expandable modular (six 8 foot sections).

**NOTE**

Additional tents, if available, can be used for food storage.

- (b) Two storage rack sets (6 storage rack assemblies).
- (c) Four oven assemblies.
- (d) Four burner racks.
- (e) Four base racks.
- (f) Two griddle assemblies.
- (g) Two steam table assemblies.
- (h) Two heater tank assemblies.
- (i) Four cooking pot cradle assemblies.
- (l) Twelve M2 burner units.
- (k) Four work tables.

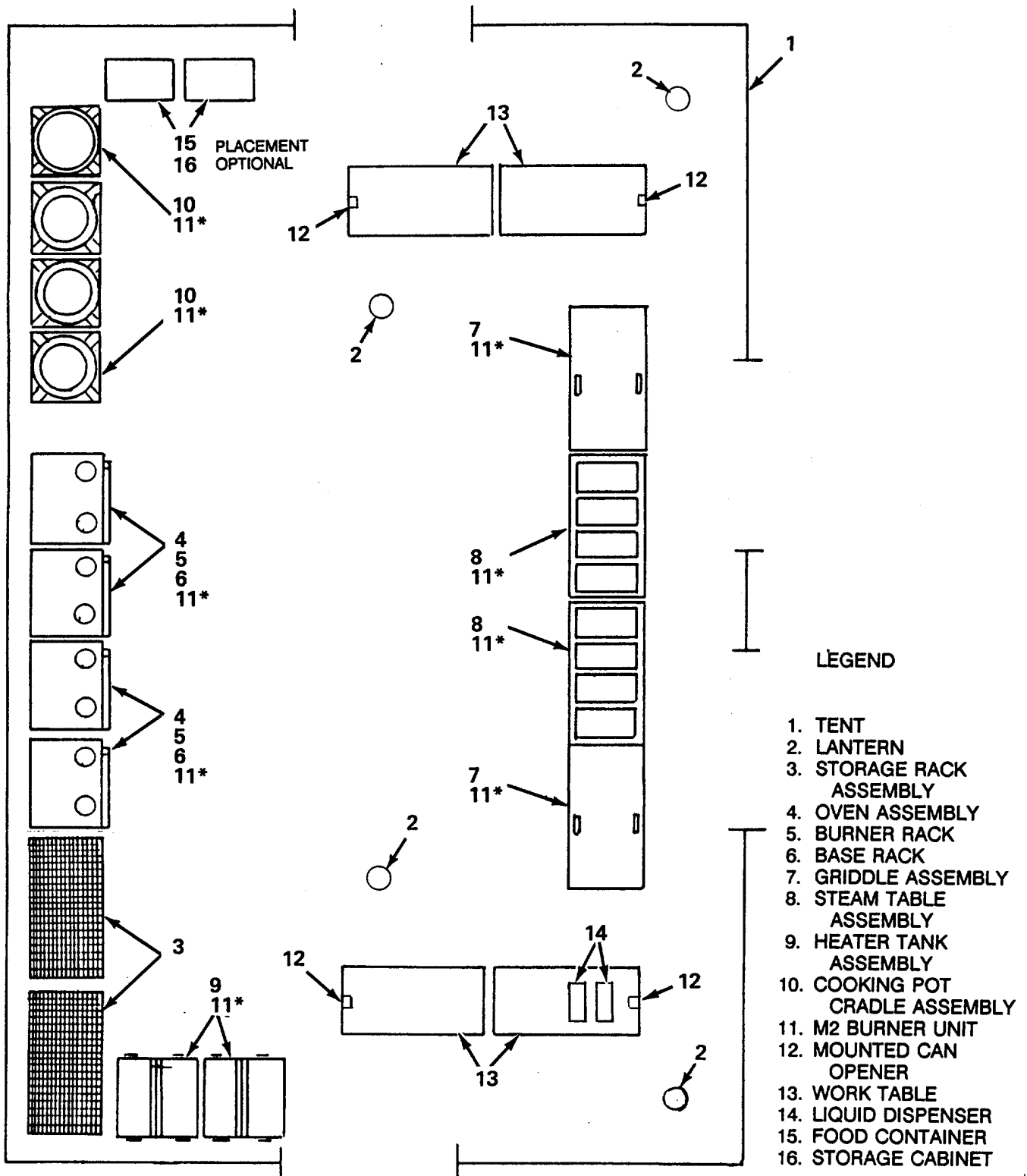

\* M2 BURNER UNIT USED WHERE NEEDED

Figure 2-2. Modular Field Kitchen - Optional Configuration, Two MFKs Consolidated

LEGEND

- 1. TENT
- 2. LANTERN
- 3. STORAGE RACK ASSEMBLY
- 4. OVEN ASSEMBLY
- 5. BURNER RACK
- 6. BASE RACK
- 7. GRIDDLE ASSEMBLY
- 8. STEAM TABLE ASSEMBLY
- 9. HEATER TANK ASSEMBLY
- 10. COOKING POT CRADLE ASSEMBLY
- 11. M2 BURNER UNIT
- 12. MOUNTED CAN OPENER
- 13. WORK TABLE
- 14. LIQUID DISPENSER
- 15. FOOD CONTAINER
- 16. STORAGE CABINET
- 17. FOOD MIXER

- A. LOADING AREA FOR INSULATED FOOD CONTAINERS.
- B. TEMPERING AREA FOR INSULATED FOOD CONTAINERS.
- C. STORAGE AREA FOR INSULATED FOOD CONTAINERS.

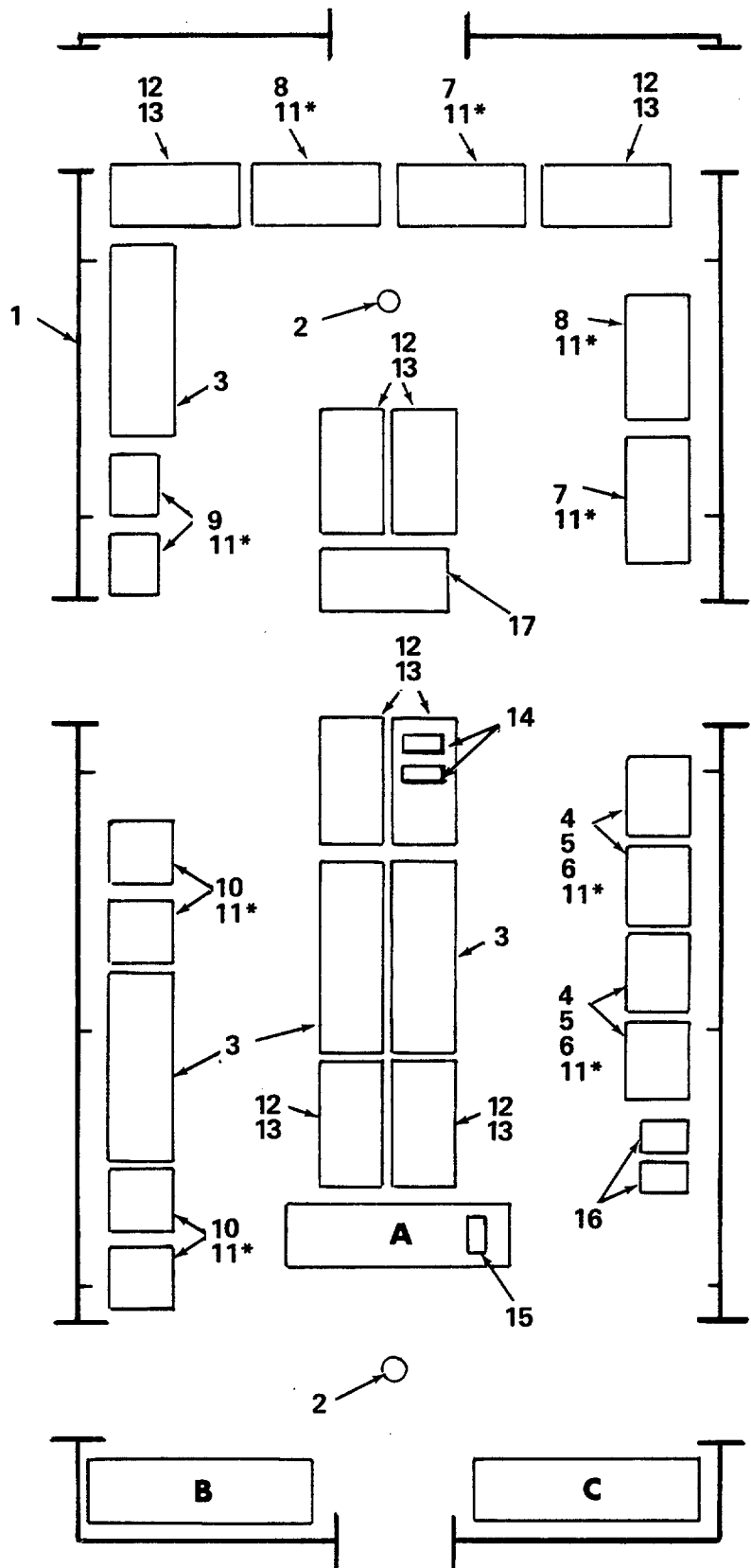

\* M2 BURNER UNIT USED WHERE NEEDED

Figure 2-3. Modular Field Kitchen - Optional Configuration, Combat Support Hospital, Deployable Medical Systems.



**2-6. ASSEMBLY AND PREPARATION FOR USE (CONT).**

(3) Procedure.

**WARNING**

Serious injury could occur if heavy equipment is moved/lifted without sufficient personnel to do the job. Use proper physical lifting procedures or use a suitable lifting device or dolly. Wear safety shoes, gloves and other suitable protective clothing.

**NOTE**

- The MFK equipment is packaged in the transport mode in accordance with paragraph 2-9.
- MFK major components in the packaged configuration weigh up to 245 pounds. Ensure adequate personnel are used to offload and carry the equipment to the operational site.

(a) Upon arrival at the selected site, set up the tent(s) as directed in TM 10-8340-224-13.

(b) Assemble and set up remaining equipment in accordance with procedures in paragraph 2-6 and as shown in Figure 2-2. ■

(c) Prepare the M2 burner units in accordance with TM 10-7360-204-13&P.

(4) Deployable Medical Systems. An optional MFK configuration, 48 X 20 foot (14.64 X 6.1 meters), used by DEPMEDS' personnel in a combat support hospital is shown in Figure 2-3. Refer to Deployable Medical Systems User's Manual for instructions.

**2-7. OPERATING PROCEDURES.****WARNING**

Familiarize yourself with the location of the fire extinguishers and MFK exits. Make sure that a fire extinguisher is at hand when operating or servicing the M2 burner units.

a. General. Before operating the MFK be familiar with the operating procedures and instructions for all of the equipment to avoid injury to personnel or damage to the equipment. While operating the MFK, additional items are required. See Appendix D and E for a complete listing.

2-7. OPERATING PROCEDURES (CONT).

b. Identification Plates and Stencils.

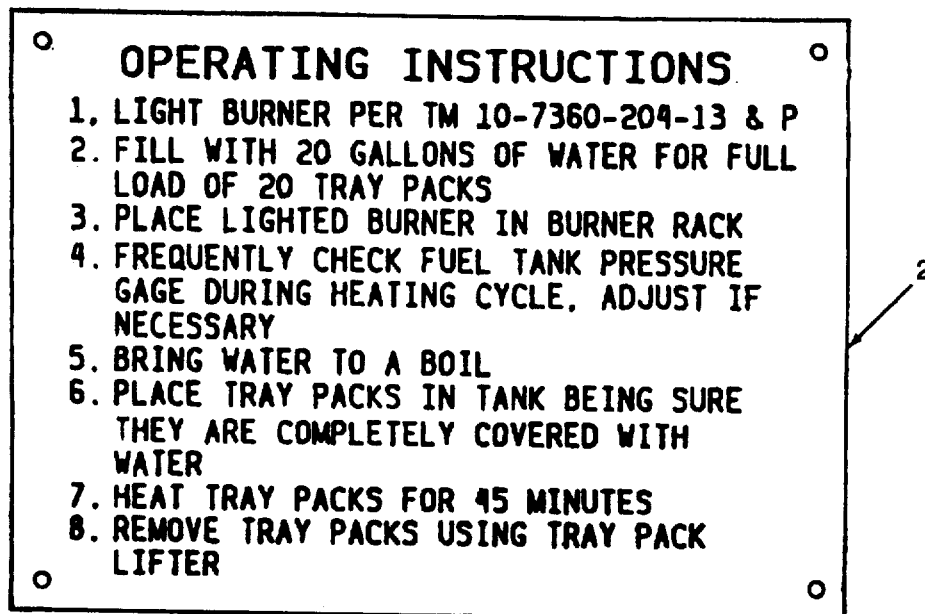

**2-7. OPERATING PROCEDURES (CONT).**

(1) Warning Plates. The warning plates (1) are attached to the griddle and the steam tables in positions which are easily viewed by the person being served. Plates are also attached to the cooking pot cradle, the heater tank, and the oven.

(2) Operating Instruction. One operating instruction plate (2) containing instructions is attached to the heater tank.

c. Preparing Water. Water is required to operate the MFK. Water must be treated in accordance with TB Med 530. Water must have a residual chlorine content of five parts per million (PPM). Additional guidance may be found in FM 10-23 and FM 10-52.

**WARNING**

- Establish a safe area for lighting M2 burner unit, a minimum of 50 feet (15.3 meters) from the refueling, fuel storage, cooking and sanitizing areas.
- Extreme heat will cause M2 burner unit tank pressure to increase because of fuel expansion. Insure you start with prescribed pressure IAW TM 10-7360-204-13&P.
- Fuel M2 burner units in servicing area only. When filling the fuel tank, always provide metal to metal contact between the container and the fuel tank. Remove spilled fuel immediately. Keep fuel tank and fuel container caps tight at all times. Do not smoke and ensure that there is no open flame in the vicinity; fire or explosion may result. Do not operate the M2 burner units if fuel or other flammable material is on or near the M2 burner units.
- Do not touch the metal surfaces of hot food preparation equipment when M2 burner units are in use. Severe burns may result.
- Frequently check for heating of the tent or shelter wall while M2 burner units are in use. Move the M2 burner units if necessary to prevent possible ignition of the tent.

d. M2 Burner Units. Proceed as follows when preparing the M2 burner units for use:

(1) Following all precautions, and instructions in TM 10-7360-204-13&P, start the M2 burner unit. Monitor the burner unit for proper flame color.

(2) When the M2 burner unit has reached a stable operating state, carefully slide it into the burner rack. Do not use force.

**WARNING**

- Allow M2 burner units and lanterns to cool before releasing air pressure from fuel tanks. Do not smoke. Make sure there is no open flame in the vicinity. Fuel fumes are explosive and highly flammable.
- Bleed all M2 burner units and lanterns of air before storage. Drain all fuel from equipment into gasoline cans before movement or storage.

**2-7. OPERATING PROCEDURES (CONT).**

(3) When no longer required for operation, turn off the M2 burner unit and allow it to cool.

e. Preparation of Rations.

(1) A and B ration preparation will be accomplished as directed by senior food service personnel.

**WARNING**

- To avoid food poisoning discard any tray-packs having the following defects:
  - Leaks where tray-packs show any evidence of damage on the exterior that may have come from a pinhole, fracture or incomplete seal.
  - Rust that actually penetrates the tray-pack causing leakage or excessive end seam rust that cannot be removed with a soft cloth and would enter the product when opening the tray-pack.
  - Dents that are so severe as to cause leakage or materially affect usability.
  - Swollen or outward distended tray lids bulging from internal pressure or swells caused by any physical damage such as dents or overheating.
  - Buckles or bends in the top and extending into the end seam of the tray-pack.
  - Handle tray-pack lids and trash bags containing tray-pack lids carefully. Sharp edges on opened lids may cause serious cuts.

(2) Tray-pack preparation. To support dispersed squad size units, heat tray-packs and place them with supplemental items such as utensils, bread, and disposable trays in the insulated food container. In MFK, tray-packs will be heated in boiling water contained in the heater tank assembly (See paragraph 2-7h). Pour hot or cold beverages into the liquid dispenser. Transport and serve rations and beverages as directed by senior food service personnel.

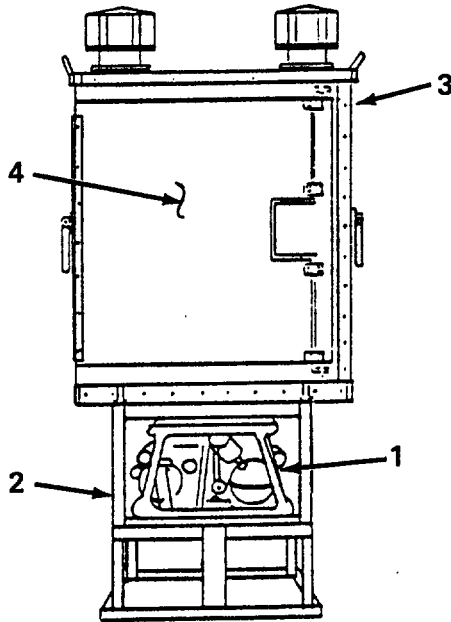
**2-7. OPERATING PROCEDURES (CONT).**f. Oven Assembly.

(1) Refer to para 2-7d and prepare and carefully slide the M2 burner unit (1) in the burner rack (2) under the oven assembly (3). Do not force.

(2) Let oven assembly (3) reach operating temperature before using (Approximately 30 minutes after lighted burner is placed under it).

(3) After use, turn M2 burner unit (1) off and allow it, and the oven to cool down. Keep oven door (4) closed.

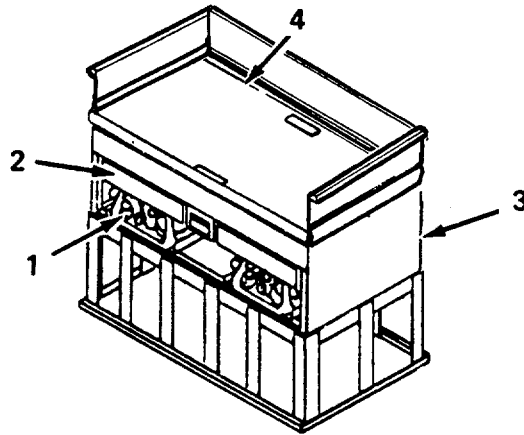
**2-7. OPERATING PROCEDURES (CONT).**g. Griddle Assembly.

(1) Refer to para 2-7d and prepare two M2 burner units (1). Raise heat guards (2) and carefully place M2 burner units in the double burner rack (3) under the griddle (4). Do not force.

(2) Let griddle reach operating temperature before use.

**WARNING**

During operation check grease accumulation. Excessive grease either on the griddle or in the container below the griddle poses a fire hazard. A grease fire may cause injury to personnel and equipment.

**CAUTION**

Do not use abrasives to clean griddle. Use of abrasives will destroy anodized protective surfaces.

(3) After use, turn off the M2 burner units (1) and allow these, and the griddle assembly to cool down.

## 2-7. OPERATING PROCEDURES (CONT).

### h. Steam Table Assembly.

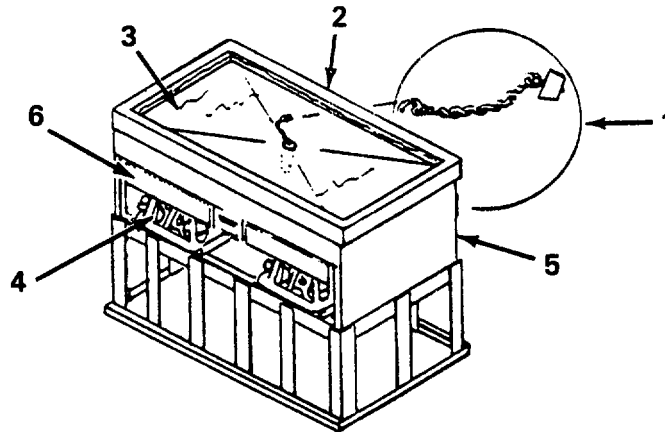

- (1) Install drain plug (1) into the steam table top (2).
- (2) Fill the steam table top (2) with 2 inches of water (3).
- (3) Refer to para 2-7d and prepare two M2 burner units (4). Raise heat guards (6) and carefully place M2 burner units in the double burner rack (5) under the steam table (2). Do not force.
- (4) Let the water in the steam table assembly warm to a minimum operating temperature of 160°F (71°C) before use.
- (5) Use the steam table adapter to support tray-packs and steam table pans above heated water.
- (6) After use, turn off the M2 burner units (4) and allow these, and the steam table, to cool down.

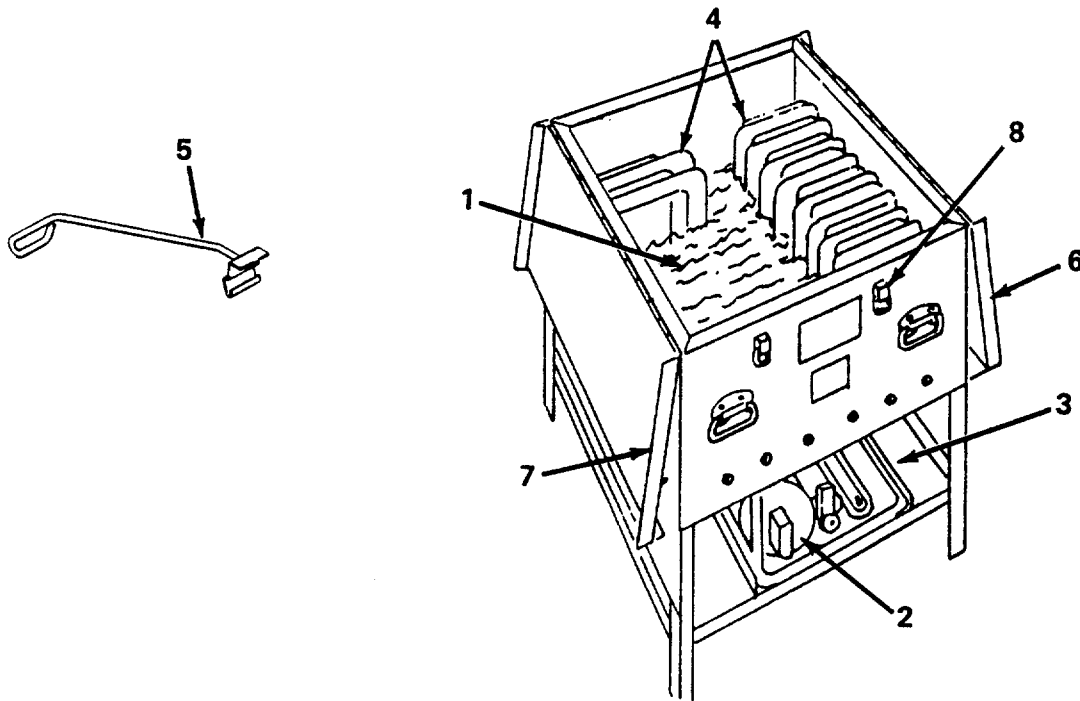
**2-7. OPERATING PROCEDURES (CONT).**i. Heater Tank Assembly.

(1) Load the heater tank assembly (1) with 20 gallons (75.7 liters) of water, approximately 8 inches (203 mm) deep.

(2) Refer to para 2-7d and prepare and carefully place the M2 burner unit (2) in the burner rack (3) under the heater tank (1). Do not force.

**NOTE**

If less than 20 trays are to be heated at one time, more than 20 gallons (75.5 liters) of water will be required to cover the trays.

(3) While the water is being heated, ready the tray-packs (4) for loading into the heater tank.

(4) When the water has begun to boil, using the tray-pack lifter (5), load a maximum of 20 tray-packs into the tank in the following manner:

(a) The trays are to be arranged on edge in two rows of ten.



**2-7. OPERATING PROCEDURES (CONT).**i. Heater Tank Assembly (Cont).

(b) The first tray-pack should be placed in the tank with the bottom of the tray-pack against the back of the tank, the short side down. Be sure the water covers the trays.

(c) Close covers (6 and 7) on tank. It is not necessary to secure covers with the catches (8). The catches are intended for use during transport.

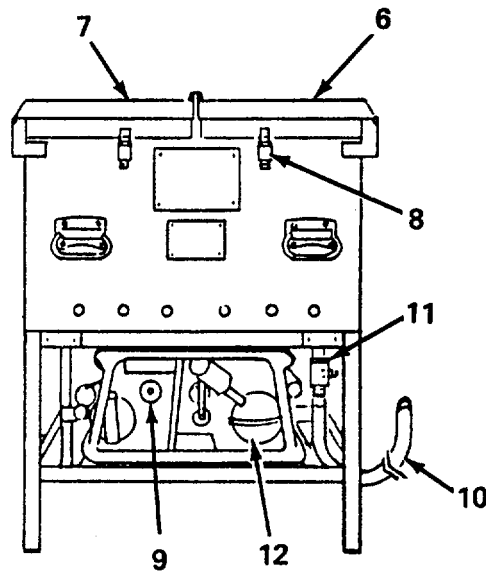

(5) Closely monitor the air pressure gage (9) on the M2 burner unit (12) while the tray-packs are being heated.

(6) After a maximum of 45 minutes in the boiling water, the tray-packs will have reached the serving temperature of 165°F (74°C).

(7) If the tray-packs are not to be served immediately or are to be served at a remote site, they should be taken from the heater tank and put into the food container (paragraph 2-71).

(8) Continued heating of the water with a lowered M2 burner unit flame will keep the tray-packs warm.

(9) If required, another load of 20 tray-packs may be loaded into the tank.

(10) Upon completion of heating or warming cycles, the M2 burner unit should be shut off. Allow the M2 burner unit and heater tank assembly to cool.

(11) After the heater tank assembly has cooled sufficiently, the water may be removed from the tank by attaching the drain hose (10) and opening the drain valve (11).

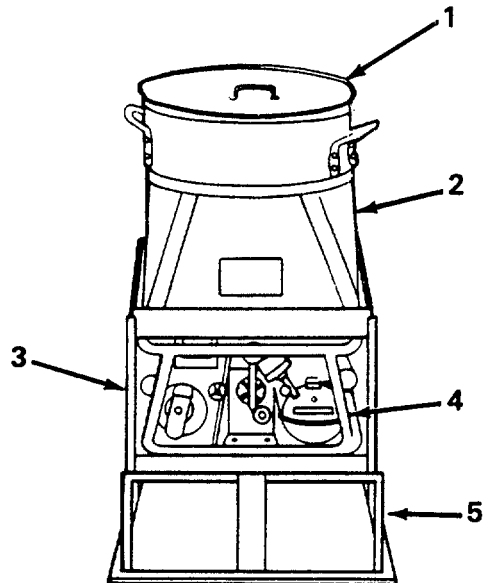
**2-7. OPERATING PROCEDURES (CONT).**j. Cooking Pot Cradle Assembly.

(1) To cook food and heat beverages, assemble a 10 or 15 gallon cooking pot (1), cradle (2), and burner rack (3) at the cooking pot cradle assembly location (Figure 2-1).

(2) Place the cooking pot (1) in the cooking pot cradle (2) atop the burner rack (3) and base rack (5).

(3) Refer to para 2-7d and prepare the M2 burner unit (4).

(4) When the M2 burner unit (4) has reached a stable operating state, carefully slide it into the burner rack (3). Do not force.

(5) Pour the liquid into the cooking pot (1) and heat to the desired temperature.

(6) Upon completion of heating cycle, turn off the M2 burner unit (4). Allow M2 burner unit (4) and cooking pot cradle assembly to cool.

**2-7. OPERATING PROCEDURES (CONT).**

- k. Dispenser, Liquid, Insulated.

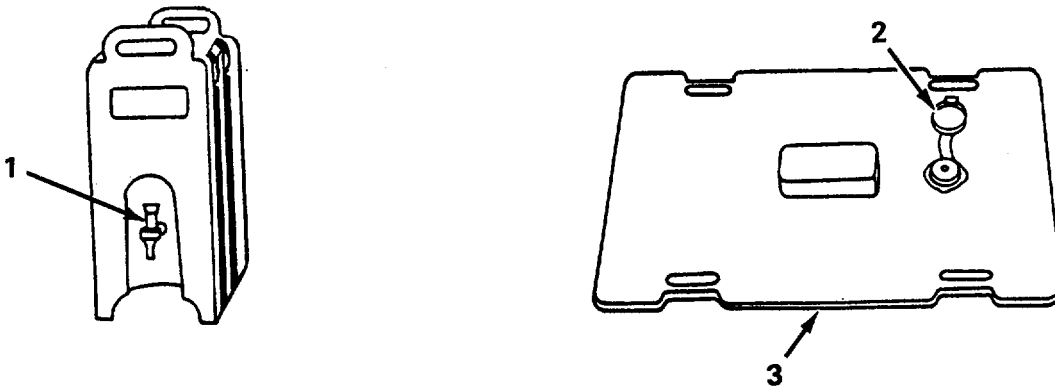

**WARNING**

Do not put milk or dairy products in the Insulated Liquid Dispenser. The dispenser cannot be thoroughly cleaned of dairy products and the residue will contaminate other liquids and may cause food poisoning.

- (1) Pour hot or cold beverages into liquid dispenser. Close vent cap (2) on lid assembly (3).
- (2) Transport to serving site and open vent cap (2), use spigot (1) to serve.

**2-7. OPERATING PROCEDURES (CONT).**

I. Food Container. Use the food container to maintain or transport A and/or B type rations and tray-packs.

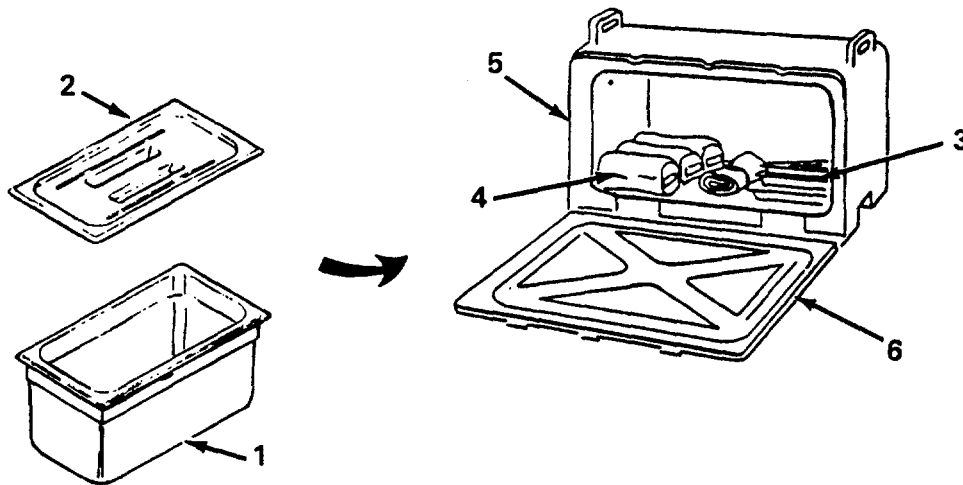

(1) Place A and/or B type rations in food serving and storage pan (1) and cover (2). Place covered pan in food container (5). Close door (6).

(2) For remote site use, place heated tray-packs (3) and supplemental items (4) such as utensils, bread, and disposable trays in the compartment of the food container (5). Close door (6).

(3) Transport to serving site and serve.

m. Storage Cabinet. Use the storage cabinet to store desserts, bread, etc.

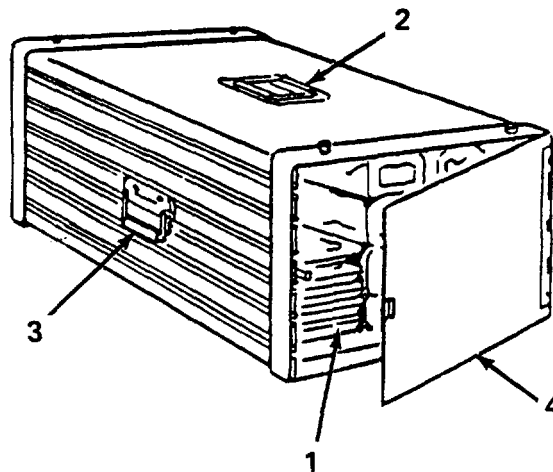

The storage cabinet holds six 19 X 22 inch (482 X 558 mm) shelf pans (1) or 150 servings of pastry items. Use the top handle (2) and side handle (3) for carrying. Close door (4) tightly to keep rations fresh.

**2-8. DISASSEMBLY AND PREPARATION FOR MOVEMENT.**

a. General. The MFK components that must be prepared and included for movement to a new site are listed in Appendix C. Refer to TM 10-8340-224-13 to strike the tent, and FM 10-23 for lantern data.

**WARNING**

**Serious injury could occur if heavy equipment is moved/lifted without sufficient personnel to do the job. Use proper physical lifting procedures or use a suitable lifting device or dolly. Wear safety shoes, gloves and other suitable protective clothing.**

**CAUTION**

**Do not use abrasives to dean griddle. Use of abrasives will destroy anodized protective surface.**

**NOTE**

**As required, clean all MFK components in hot, soapy water. Rinse with dean water and dry thoroughly prior to disassembly and packaging.**

b. Disassembly. Disassemble the MFK and prepare for movement as follows:

**WARNING**

- Allow the M2 burner units and lanterns to cool before releasing air pressure from fuel tanks. Do not smoke and make sure there is no open flame in the vicinity. Fuel fumes are explosive and highly flammable.
- Bleed all M2 burner units and lanterns of air before storage.
- Drain all fuel from equipment into fuel can before movement or storage.

(1) M2 Burner Units. Prepare the M2 burner units for movement as follows:

(a) Remove the M2 burner units from the food preparation equipment. Drain the gasoline tanks and prepare the M2 burner units for movement in accordance with TM 10-7360-204-13&P.

(b) Return M2 burner units to respective burner racks.

**NOTE**

**The MFK is issued with six M2 burner units, but there are nine open burner rack cavities. For disassembly and movement, retain the M2 burners in the following:**

- **Two Oven Assemblies (One M2 burner unit in each)**
- **One Heater Tank Assembly (one M2 burner unit)**
- **Two Cooking Pot Cradle Assemblies (one M2 burner unit in each)**
- **One Griddle Assembly (one M2 burner unit in double burner rack)**

2-8. DISASSEMBLY AND PREPARATION FOR MOVEMENT (CONT).

b. Disassembly (Cont.

(2) Storage Rack Assembly.

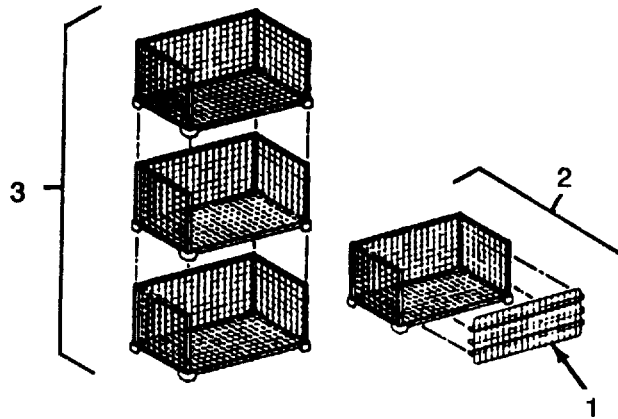

(a) Remove the shelves (front cover) (1) from the storage rack assembly (2).

(b) Disassemble the stacked rack units (3) and place the front cover (1) on each storage rack assembly (2).

(3) Oven Assembly.

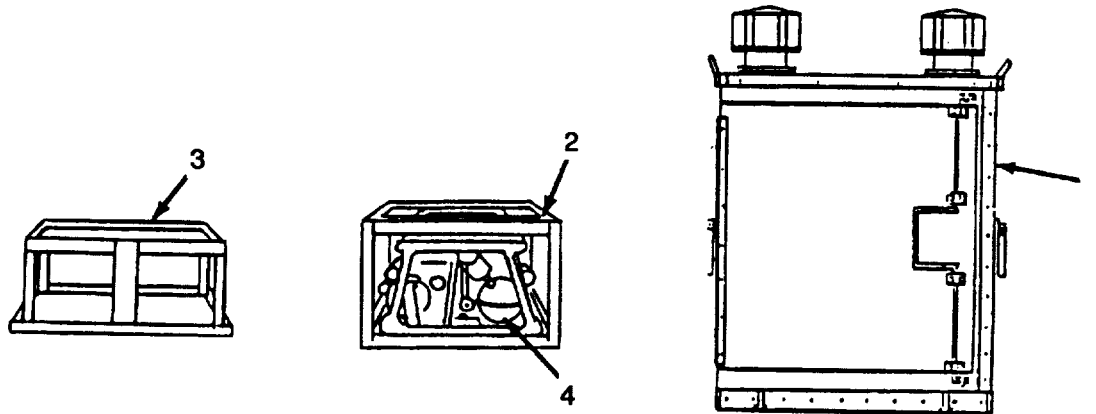

(a) Refer to para 2-8b(1) and ensure the M2 burner unit is prepared for movement.

(b) Separate the oven assembly (1), burner rack (2), and base rack (3); return the M2 burner unit (4) to the burner rack (2).

2-8. DISASSEMBLY AND PREPARATION FOR MOVEMENT (CONT).

b. Disassembly (Cont).

(4) Griddle Assembly.

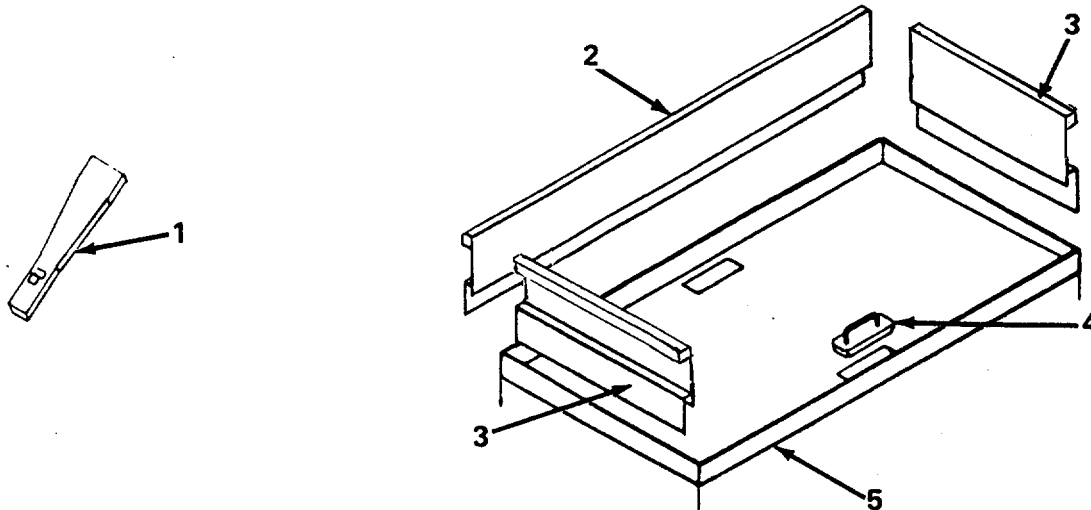

- (a) Refer to para 2-8b(1) and ensure M2 burner unit is prepared for movement.
- (b) Remove the grease chute (1).
- (c) Remove the long splash guard (2), the two short splash guards (3) and the grease slot plug (4).

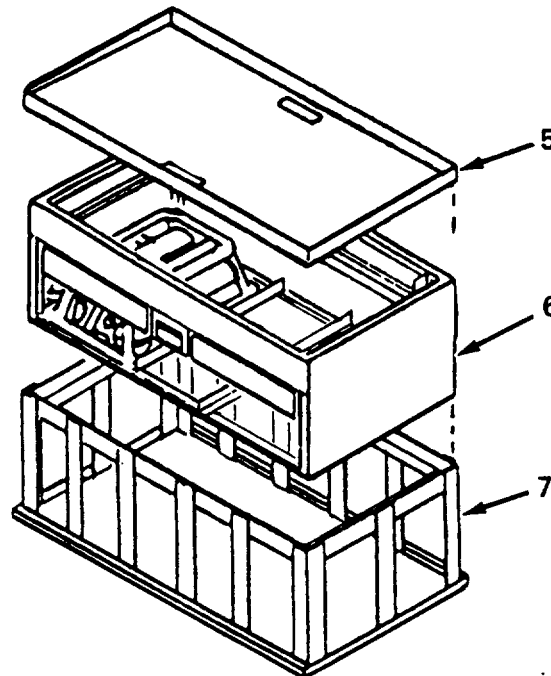

- (d) Separate and remove the griddle top (5) from the double burner rack (6) and base rack (7).

**2-8. DISASSEMBLY AND PREPARATION FOR MOVEMENT (CONT).**

b. Disassembly (Cont).

(5) Steam Table Assembly

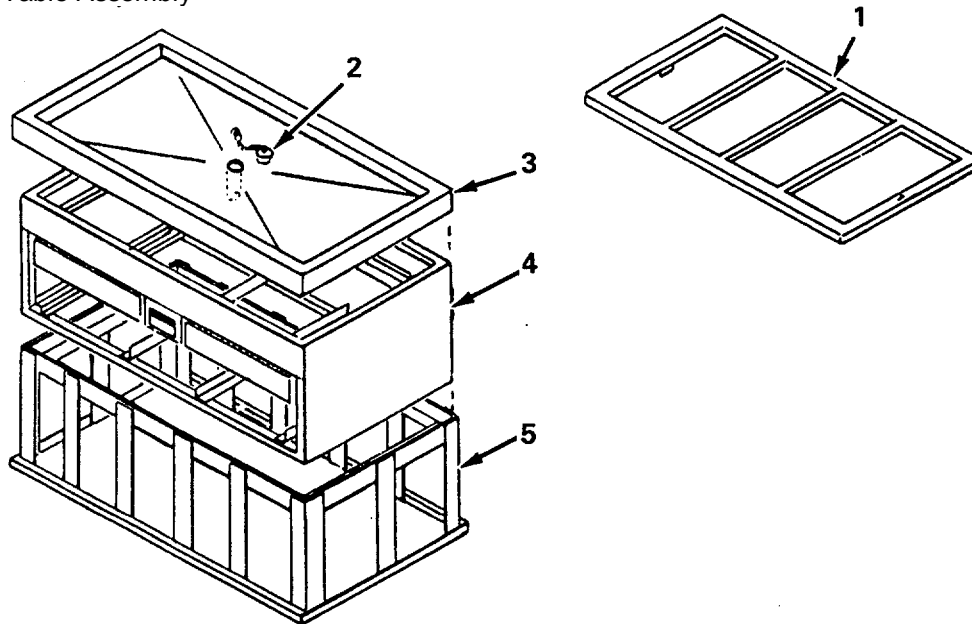

- (a) Remove the top adapter (1) and/or the roasting and baking pans (if used).
- (b) Pull the stopper (2) and drain water.
- (c) Separate and remove the steam table body (3) from the double burner rack (4) and double base rack (5).

(6) Heater Tank Assembly.

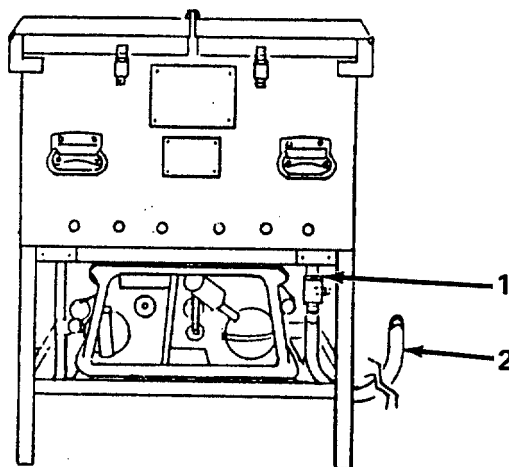

- (a) Refer to para 2-8b(1) and ensure the M2 burner unit is prepared for movement.
- (b) Open the drain valve (1) to remove the water, then disconnect the drain hose (2).



**2-8. DISASSEMBLY AND PREPARATION FOR MOVEMENT (CONT).**

b. Disassembly (Cont).

(7) Cooking Pot Cradle Assembly.

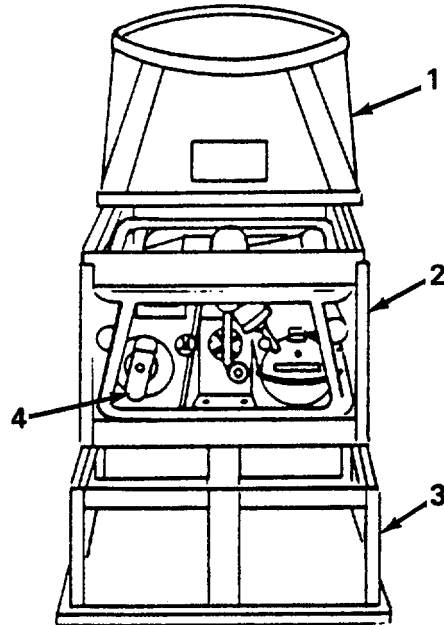

(a) Refer to para 2-8b(1) and ensure the M2 burner unit (4) is prepared for movement.

(b) Separate the cooking pot cradle (1), burner rack (2), and base rack (3). Return the M2 burner unit (4) to burner rack (2).

2-8. DISASSEMBLY AND PREPARATION FOR MOVEMENT (CONT).

b. Disassembly (Cont).

(8) Work Table.

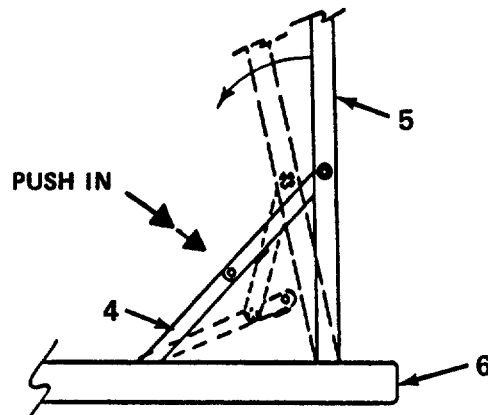
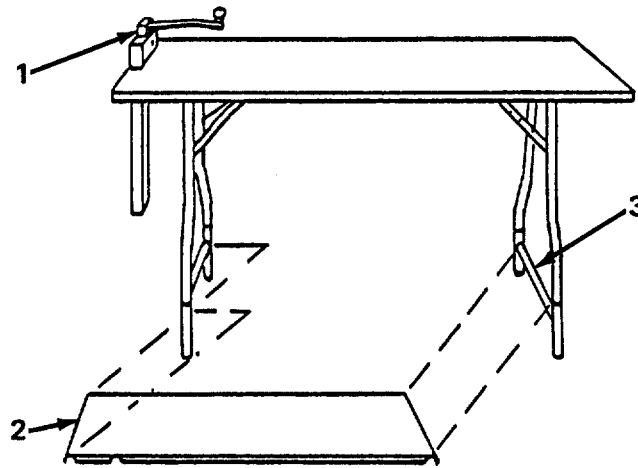

- (a) Remove the mounted can opener (1) from the can opener slot in the work table by lifting it out vertically.
- (b) Remove the shelf (2) from the table leg crossbars (3).
- (c) Turn the work table upside down and push-in the linkage (4). Fold up the table legs (5) so that they lie against the underside of the table top (6).

**2-9. PACKAGING.**

All items that must be packaged for movement prior to packing (loading the truck) are listed in Appendix C. Space available in the steam table body assembly, the heater tank assembly, the tool chest, the five roasting and baking pans, one steam table and griddle frame, the ovens, the storage cabinets, and the burner rack and base is used for packaging other components as described in the paragraphs below.

**WARNING**

Serious injury could occur if heavy equipment is moved/lifted without sufficient personnel to do the job. Use proper physical lifting procedures or use a suitable lifting device or dolly. Wear safety shoes, gloves and other suitable protective clothing.

**NOTE**

MFK major components in the packaged configuration weigh up to 245 pounds. Ensure adequate personnel are used to carry and load the equipment on the vehicles.

a. Storage Racks Assembly (Three-Piece Set).

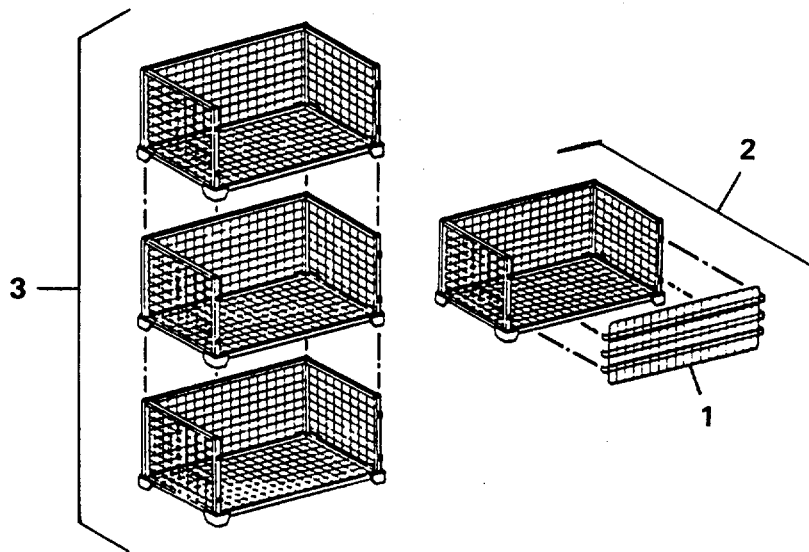

- (a) Remove the shelves (front cover) (1) from the storage rack assembly (2).
- (b) Disassemble the stacked rack units (3) and place the front cover (1) on each storage rack assembly (2).

2-9. PACKAGING (CONT).

b. Storage Racks Assembly (Two-Piece Set).

**NOTE**

Requires four persons to lift.

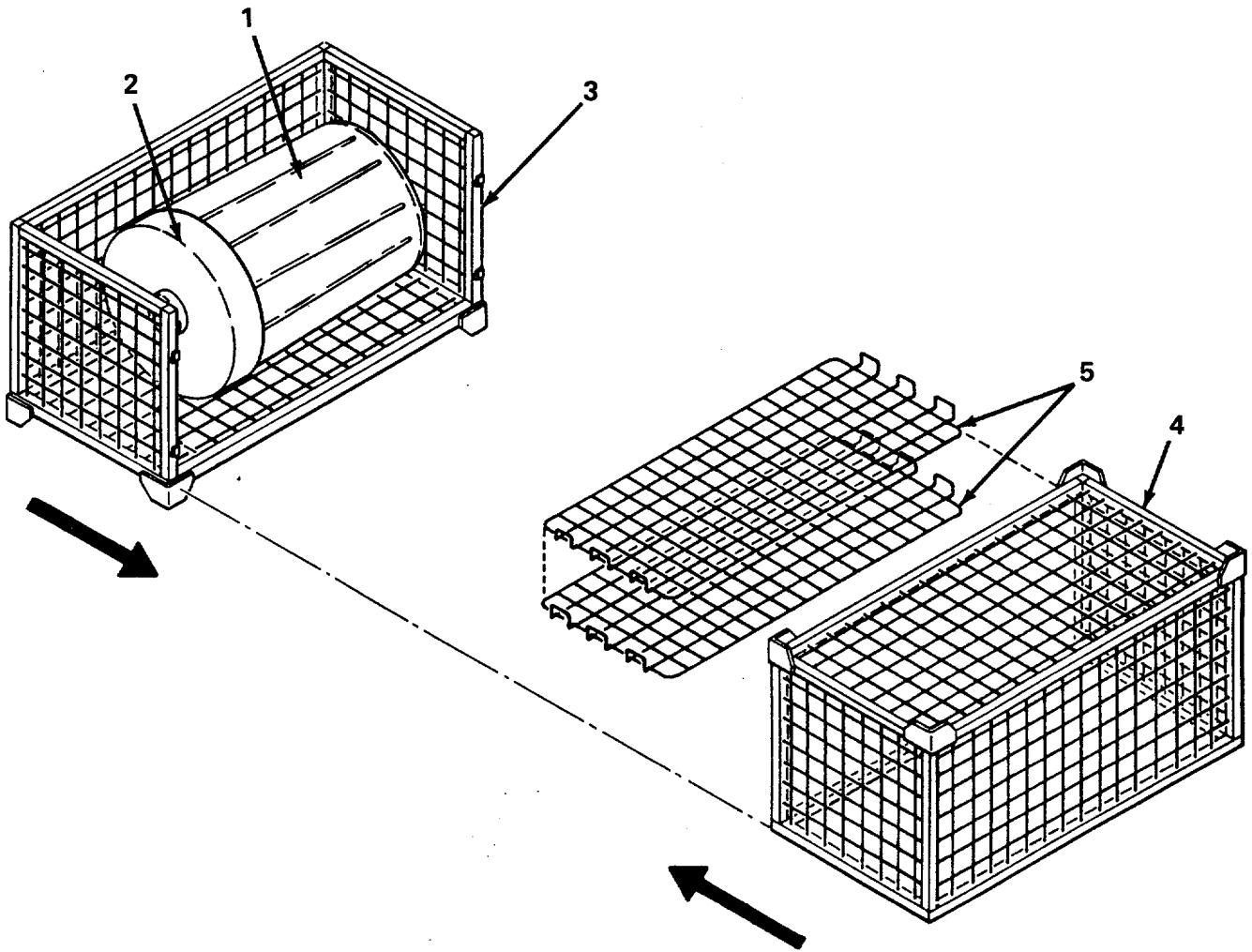

**2-9. PACKAGING (CONT).**

b. Storage Racks Assembly (Two-Piece Set) (Cont).

- (a) Place the waste receptacle (1) with nested cover (2) into one storage rack assembly (3).
- (b) Position another empty storage rack assembly (4) close to the packaged one (3).
- (c) Install as low as possible, two shelves (5) into the empty storage rack assembly (4).

**WARNING**

Serious injury could occur if heavy equipment is moved/lifted without sufficient personnel to do the job. Use proper physical lifting procedures or use a suitable lifting device or dolly. Wear safety shoes, gloves and other suitable protective clothing.

- (d) Use two-man lift (one man each end), carefully rotate the two-shelved storage rack (4) and (5). The bottom is now top.
- (e) Position each of the storage rack assemblies so that each of its empty sides face each other.
- (f) Slide each storage rack assembly together to form a box.

c. Storage Rack Assembly (One-Piece Set).

**NOTE**

Requires two persons to lift.

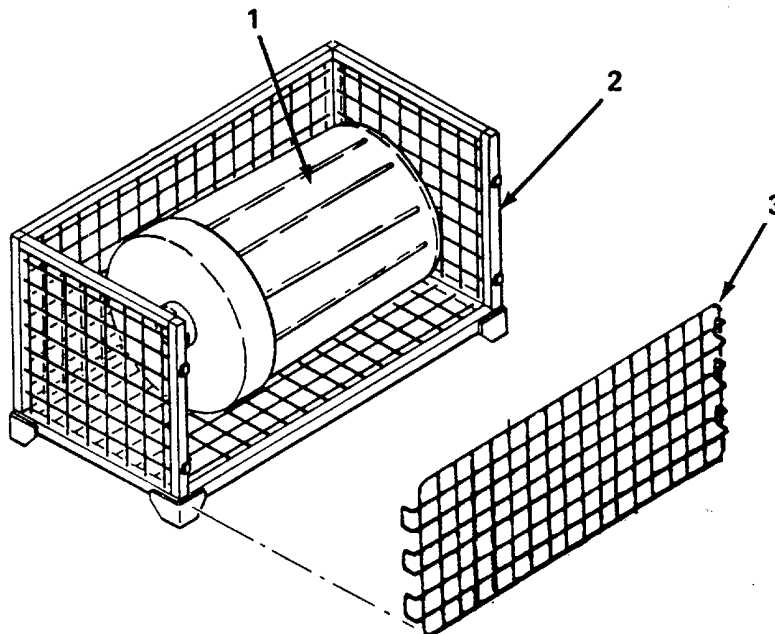

- (a) Place the waste receptacle (1) into one storage rack assembly (2).
- (b) Assemble one shelf (3) on open side of storage rack assembly (2).

**2-9. PACKAGING (CONT).**d. Oven Assembly.**NOTE**

Requires nine persons to lift.

(1) Package the items below into one of the oven assemblies.

- (a) Place the four oven racks (1) at the bottom of the oven assembly (2).
- (b) Place the 15 gallon cooking pot (3) into the cooking pot cradle (4).
- (c) Place the 10 gallon cooking pot (5) into the 15 gallon cooking pot (3).
- (d) Place two vent caps (6) into the 10 gallon cooking pot (5).
- (e) Place the colander (7) over the vent caps (6).
- (f) Place one splash plate (8) over the colander (7).
- (g) Place one cooking pot cover (9) over the splash plate (8).
- (h) Place the stacked items (3) thru (9) on the oven racks (1) in the oven assembly (2).
- (i) Place one cooking pot cover (10) to the left of the stack.
- (j) Place one splash plate (11) to the right of the stack.
- (k) Close and latch the oven door.

(2) Package the second oven assembly in the same manner as above, except without the colander (7). Two additional cooking pot covers (10) will be placed on stack.

2-9. PACKAGING (CONT).

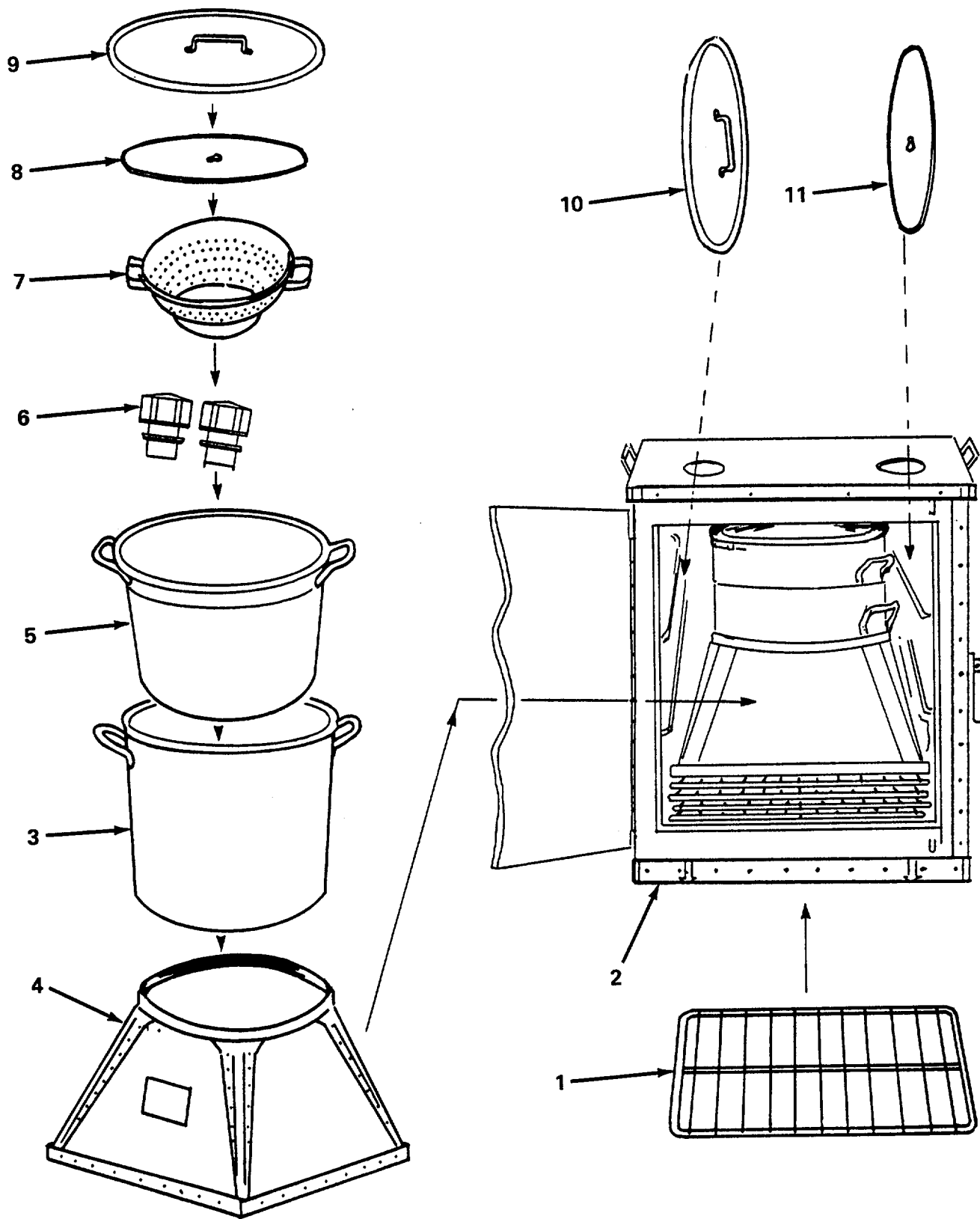

2-9. PACKAGING (CONT).

- e. Burner Rack, Base Rack and M2 Burner Units.

**NOTE**

Requires two persons to lift.

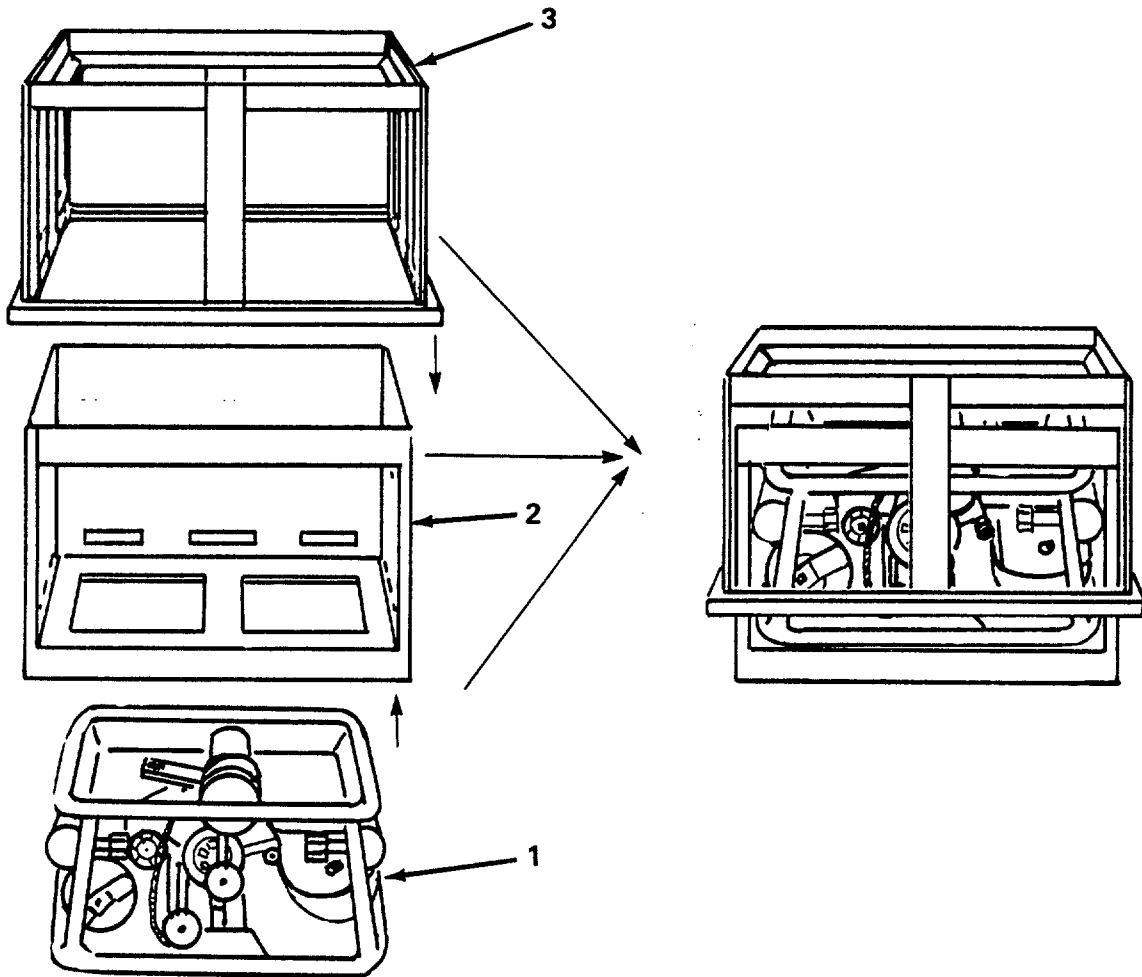

(1) Ensure the six M2 burner units are prepared for movement in accordance with TM 10-7360-204-13&P and para 2-8b.

(2) Insert the M2 burner unit (1) into the burner rack (2).

(3) Place the bottom of the base rack (3) over the burner rack (2).

(4) The remaining two M2 burner units will be packaged; one in the heater tank assembly, the other in the griddle assembly double burner rack.



**2-9. PACKAGING (CONT).**

- f. Griddle Top, Double Burner Rack, and M2 Burner Unit.

**NOTE**

Requires five persons to lift.

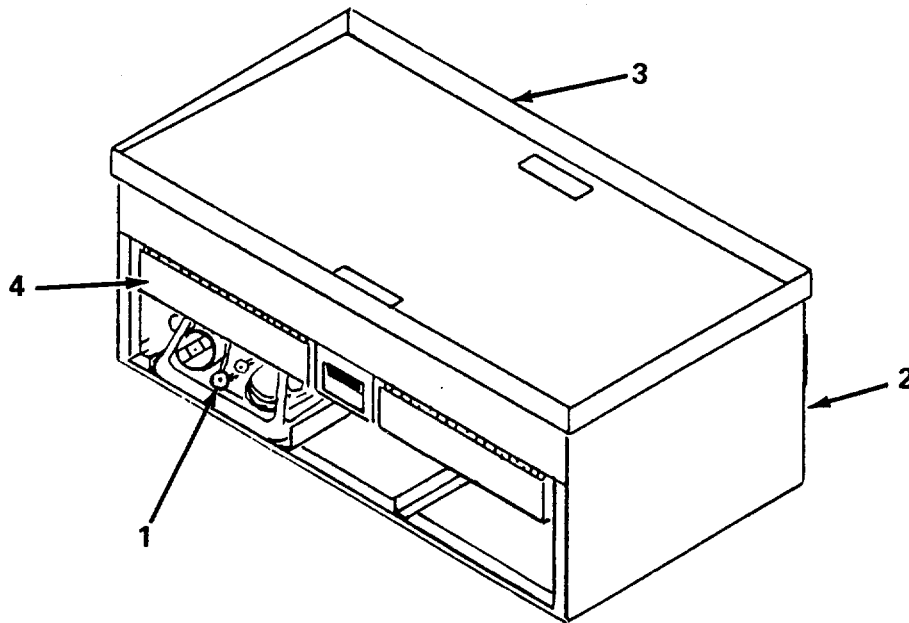

- (1) Raise up heat guard (4).
- (2) Place one M2 burner unit (1) in the double burner rack (2).
- (3) Place the griddle top (3) on the double burner rack (2).
- (4) Ensure both heat guards are lowered.

**2-9. PACKAGING (CONT).**

g. Steam Table Body. Package the following items into the steam table body.

**NOTE**

Requires three persons to lift.

- (1) Grease slot plug (1).
- (2) Grease chute (2).
- (3) Two splash guards (3).
- (4) Top adapter on top (4).

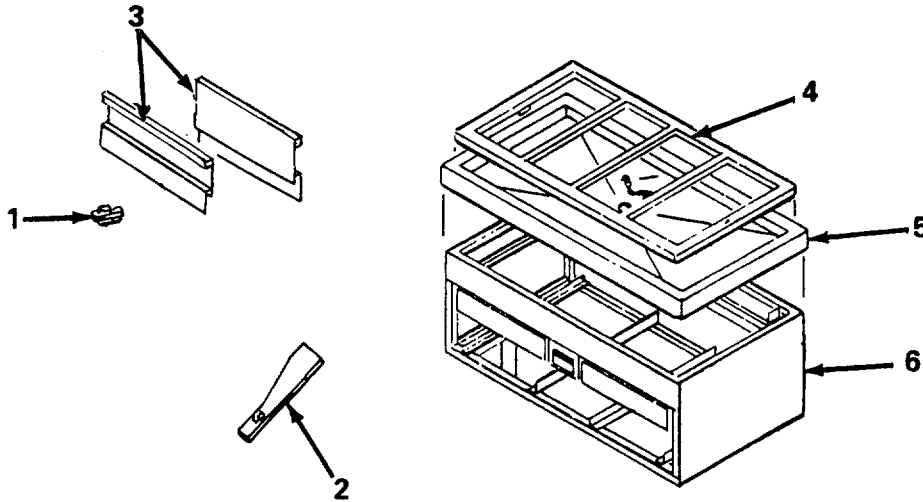

Place the above items (1) thru (4) on a steam table body (5) and double burner rack (6).

2-9. PACKAGING (CONT).

h. Double Base Rack. Prepare the double base racks for movement by nesting the griddle assembly and steam table assembly into the racks as follows:

**NOTE**

Requires the following persons to lift.  
 Griddle Assembly - eight persons  
 Steam Table Assembly - six persons

- (1) Set the griddle top (1) and double burner rack (2) into an inverted base rack (3).
- (2) Place a base rack (3) over the steam table assembly (4).
- (3) Place the long splash guard (5) on top of the adapter (diagonally).

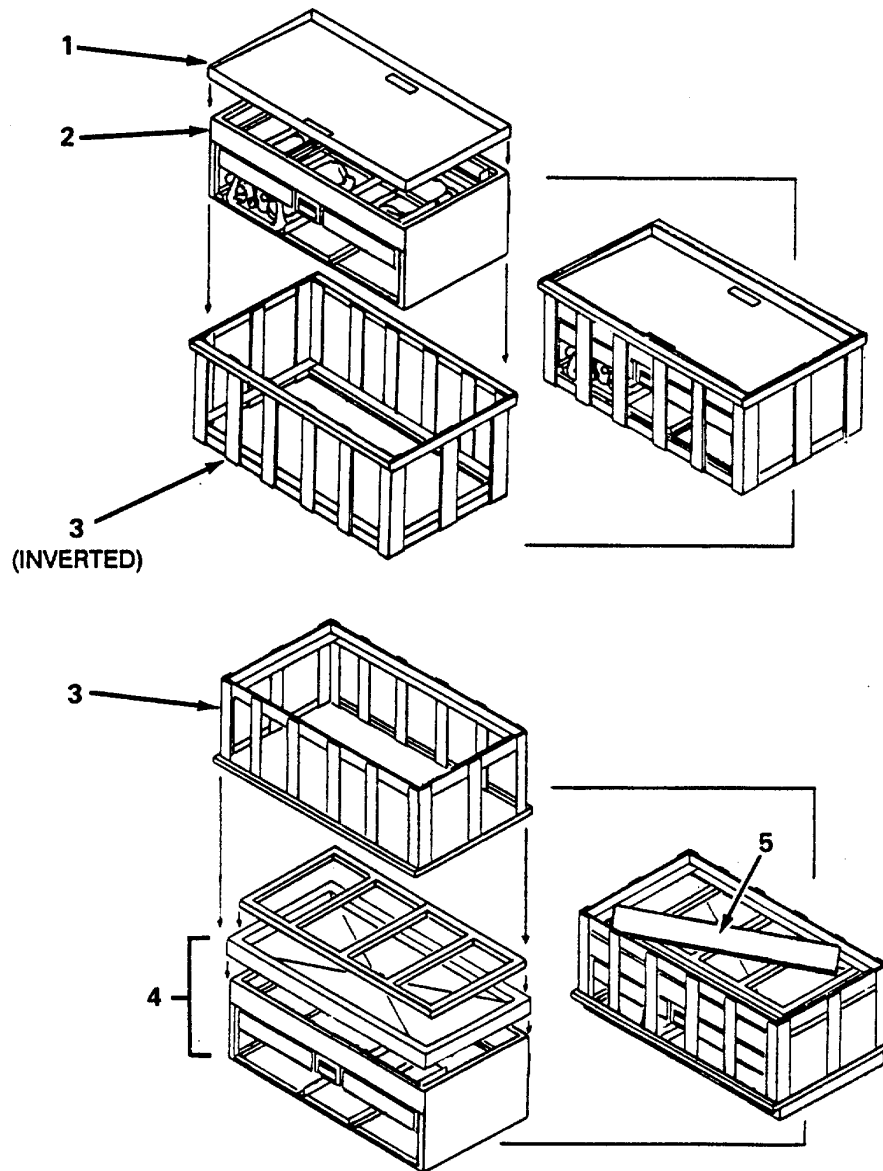

**2-9. PACKAGING (CONT).**

- i. Heater Tank Assembly. Package the following items into the heater tank assembly.

**NOTE**

Requires seven persons to lift.

- (1) One water sterilizing bags (1).
- (2) Two gasoline lanterns (2), placed in their shipping cartons (3), or barrier material (item 3, Appendix E). Place one in the upper left corner (4), and one in the lower right corner (5) of the heater tank assembly (6).
- (3) Two fire extinguishers (7) in the spaces between the corners and the gasoline lanterns.
- (4) One inflating pump (8).
- (5) The heater tank drain hose (9), with the ends screwed together, then close and latch the covers.
- (6) One M2 burner unit in place.

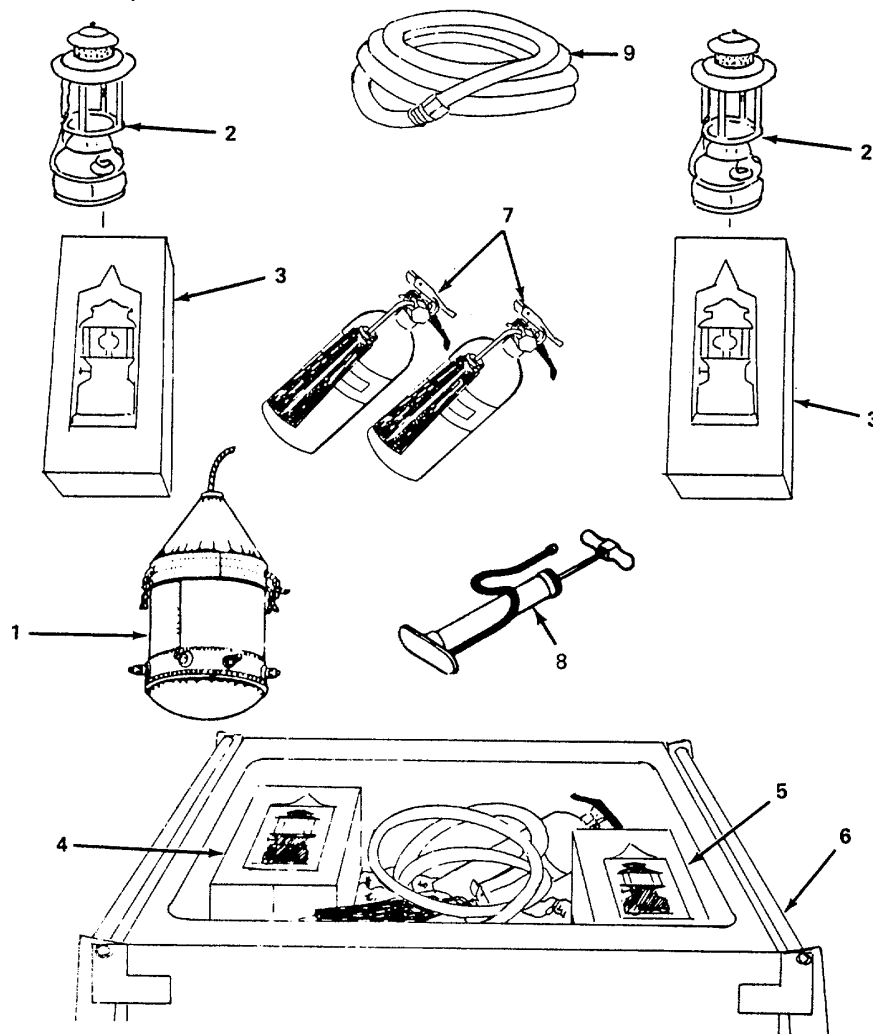

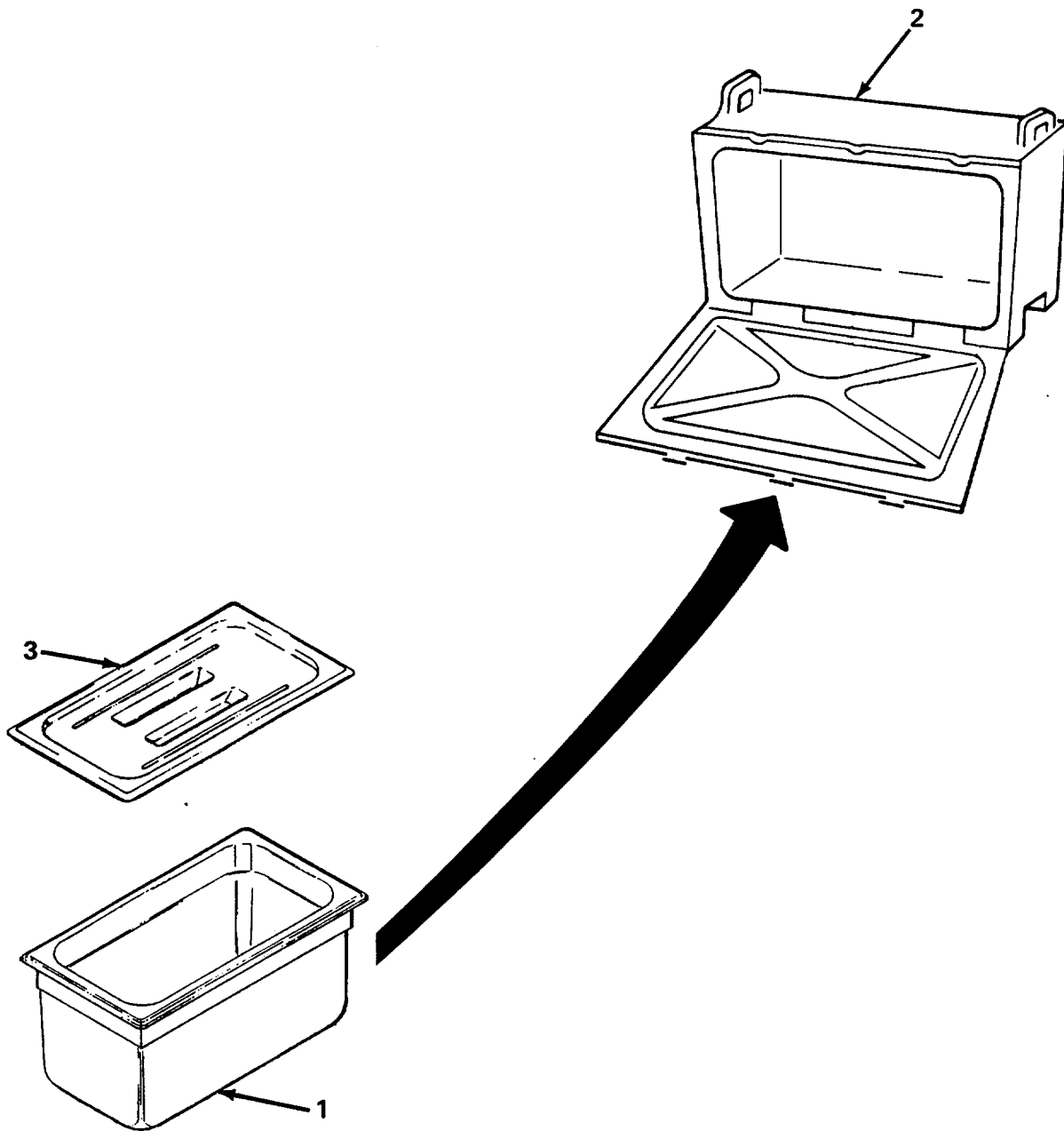
**2-9. PACKAGING (CONT).**j. Food Containers

- (1) Nest the food storage and serving pans (1) in sets of three.
- (2) Stow two sets side-by-side (six pans) in each food container (2).
- (3) Stow six food serving pan covers (3) in each food container (2).

## 2-9. PACKAGING (CONT).

k. Storage Cabinet (1 of 2).**NOTE**

Requires two persons to lift.

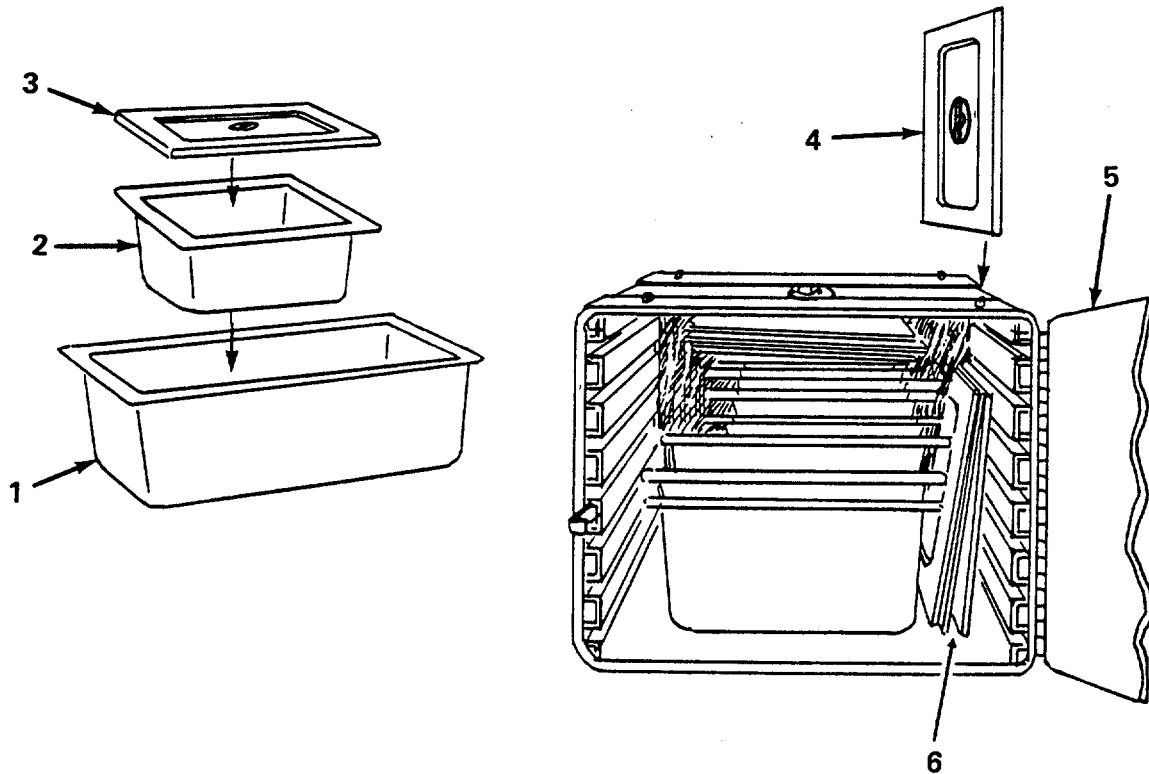

- (1) Nest three steam table pans (4-inch, full size) (1).
- (2) Nest six steam table pans (4-inch, half size) (2) and place in the stack formed in (1) above.
- (3) Stack three steam table covers (half-size pan) (3) and place on the stack formed in (2) above.
- (4) Stack and place three steam table covers, (half-size pan) (4) to the right in the storage cabinet (6).
- (5) Close and latch the door (5).

**2-9. PACKAGING (CONT).**I. Storage Cabinet (2 of 2).**NOTE**

Requires two persons to lift.

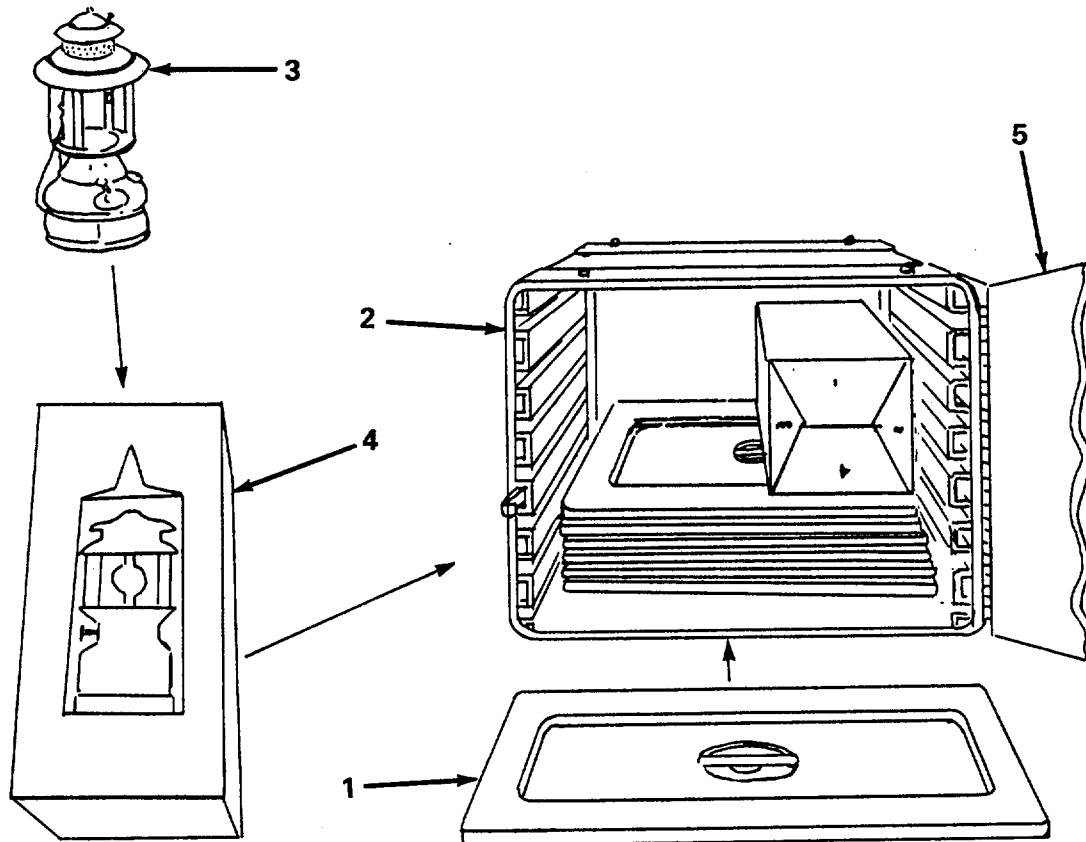

(1) Stack six steam table covers (full size) (1) and place them in the storage cabinet (2).

(2) Place one gasoline lantern (3) in its carton (4) or barrier material (Item 3, Appendix E) and place it in the storage cabinet (2).

(3) Close and latch the door (5).

**2-9. PACKAGING (CONT).**

m. Tool Chest. Package the following items in quantities shown into the tool chest:

- |      |                               |                                |
|------|-------------------------------|--------------------------------|
| (1)  | Anti-seize Compound           | 1                              |
| (2)  | Wire Brush                    | 1                              |
| (3)  | Slip Cover Top Can            | 1                              |
| (4)  | Burner Slot Cleaner           | 1                              |
| (5)  | First Aid Kit                 | 1                              |
| (6)  | Preheater Generator           | 6 (Stow in slip cover top can) |
| (7)  | Hammer                        | 1                              |
| (8)  | Craftsman Knife               | 2                              |
| (9)  | General Lubricating Oil       | 1                              |
| (10) | Gasoline Can Spout            | 1                              |
| (11) | Slip Joint Pliers             | 1                              |
| (12) | Flat Screwdriver              | 1                              |
| (13) | Phillips Screwdriver          | 1                              |
| (14) | Sharpening Stone              | 1                              |
| (15) | Adjustable Wrench             | 1                              |
| (16) | Wrench Assembly (Combination) | 1                              |



2-9 PACKAGING (CONT).

m. Tool Chest (Cont).

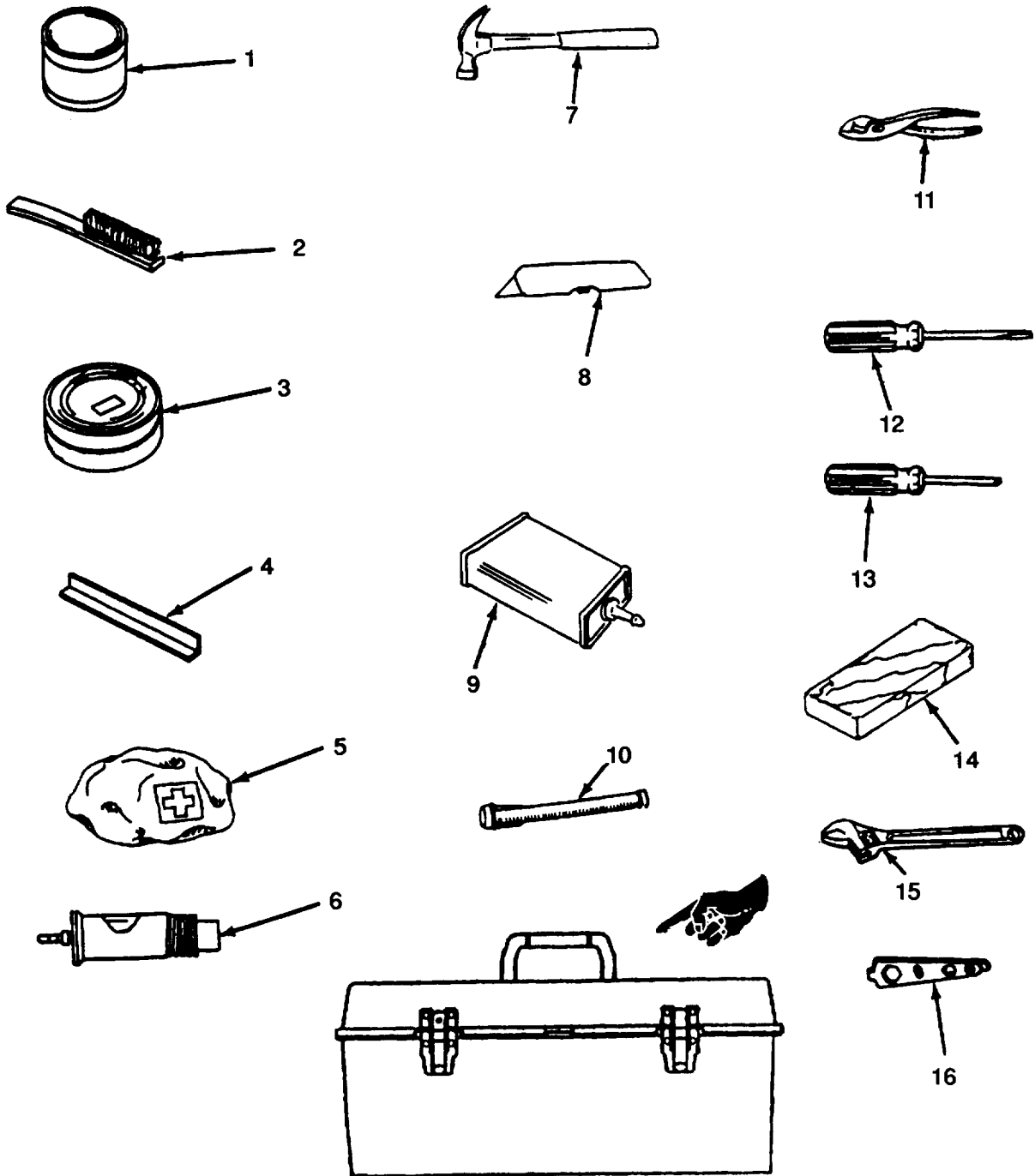

2-9. PACKAGING (CONT).

n. Roasting and Baking Pan (1 and 2 of 5) (Item 40. Appendix C). Use two bottom roasting and baking pans (1). In each one, place the following items and then cover with the roasting and baking pan cover (2) (item 8A, Appendix C).

**NOTE**

Each set requires two persons to lift.

- (1) Five rectangular baking pans (3) (item 38, Appendix C).
- (2) One food chopping board (4) (item 2, Appendix C).

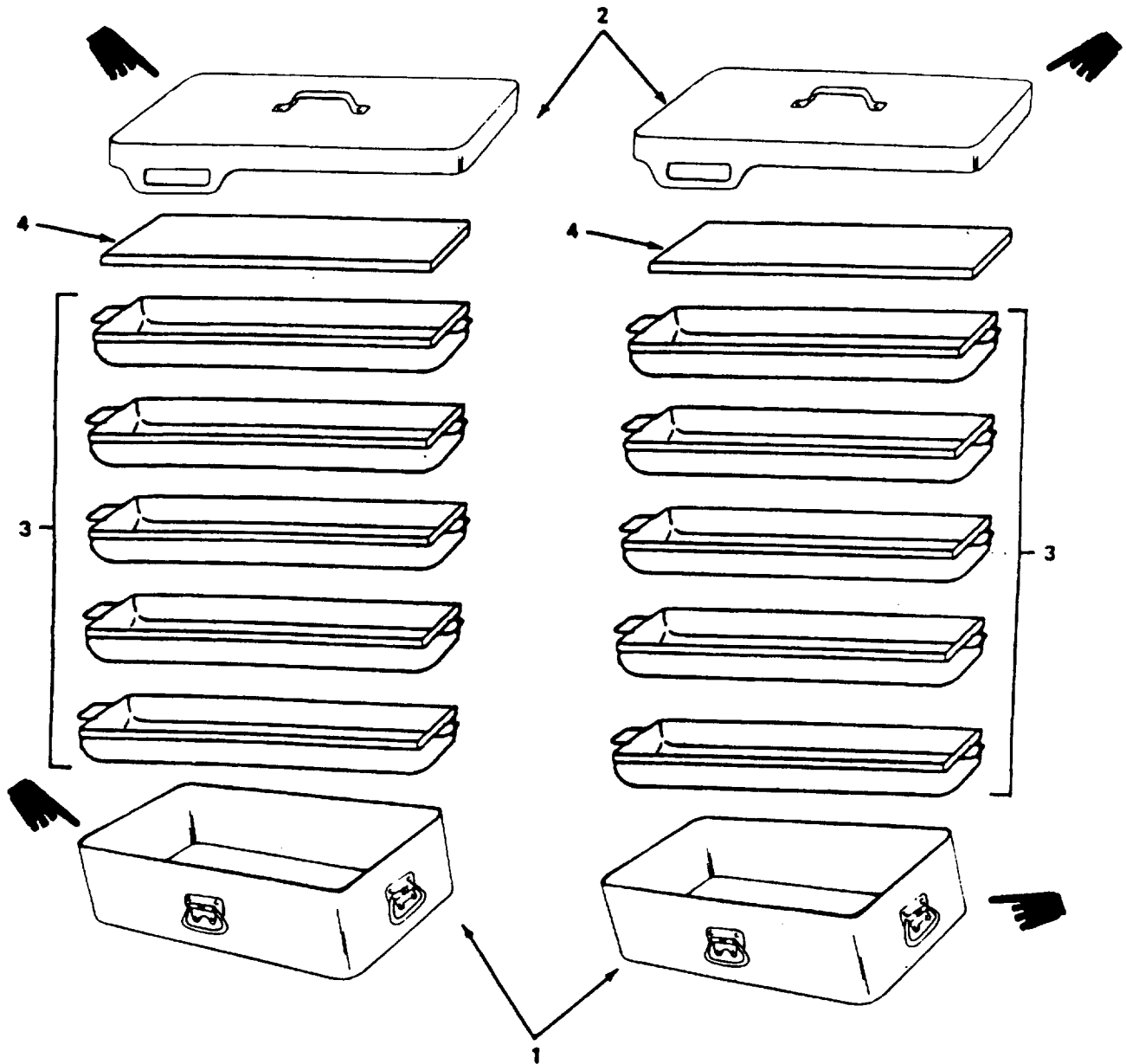

**2-9. PACKAGING (CONT).**

o. Roasting and Baking Pan (3 of 5) (Item 40, Appendix C). Insert the following items in quantities shown and then cover with the roasting and baking pan cover (20) (item 8A, Appendix C).

**NOTE**

Requires two persons to lift.

	Qty.
1. Cookie Cutter Set	1
2. Kitchen Dipper	2
3. Egg Whip	1
4. Food Turner	3
5. 15-inch Food Preparation Fork	3
6. 21-inch Food Preparation Fork	3
7. 2-ounce Kitchen Ladle	2
8. 8-ounce Kitchen Ladle	2
9. Tray-Pack Lifter	2
10. Serving Tray-Pack Lifter	2
11. Measuring Spoon Set	2
12. Hand Can Opener	2
13. Pie and Cake Server	1
14. Kitchen Skimmer	2
15. Food Service Spoon (15-inch)	4
16. Food Service Spoon (21-inch)	4
17. Food Service Spoon (Slotted, 15-inch)	8
18. Food Serving Tongs	3
19. Spatula	2

2-9 PACKAGING (CONT).

- o. Roasting and Baking Pan (3 of 5) (Item 40, Appendix C) (Cont).

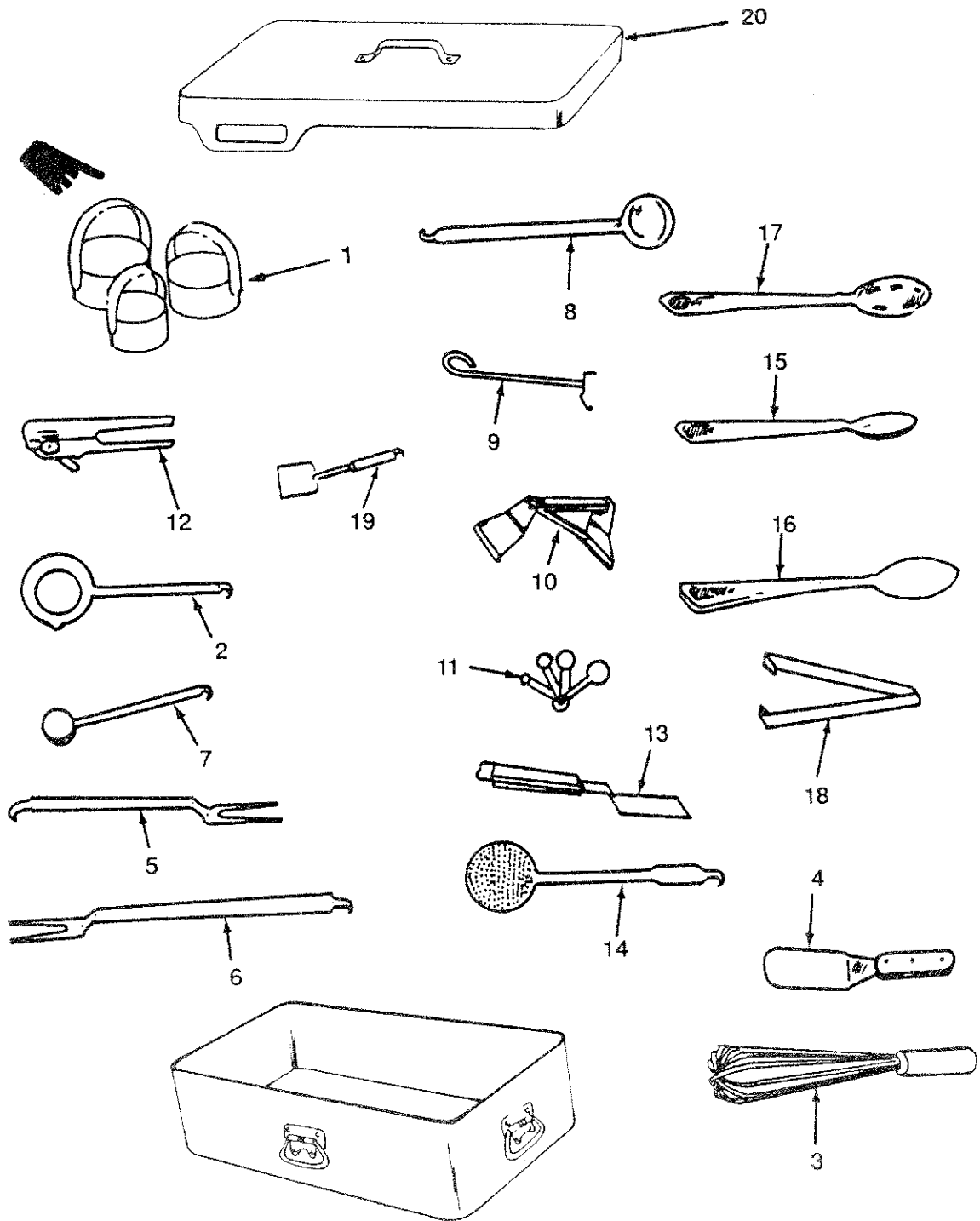

**2-9. PACKAGING (CONT).**

p. Roasting and Baking Pan (4 of 5) (Item 40. Appendix C).

(1) Package the following items in quantities shown into the cutlery roll (7) even though there is not a slot for each item:

	Qty.
1. Boning Knife	2
2. Cook's Knife	2
3. Paring Knife	2
4. Slicing Knife	2
5. Hand Potato Peeler	2
6. Ice Pick	1

(2) Place packaged cutlery roll (7) into pan. Also insert the following:

8. 2 Quarts Liquid Measure	2
9. Pot Holder	4
10. Rolling Pin	1
11. Baker's Scraper	1
12. Hand Flour Sifter	1
13. Butchers Steel	1

(3) Cover with roasting and baking pan cover (14), (Item 8A, Appendix C)

2-9. PACKAGING (CONT).

q. Roasting and Baking Pan (4 of 5) (Item 40. Appendix C).

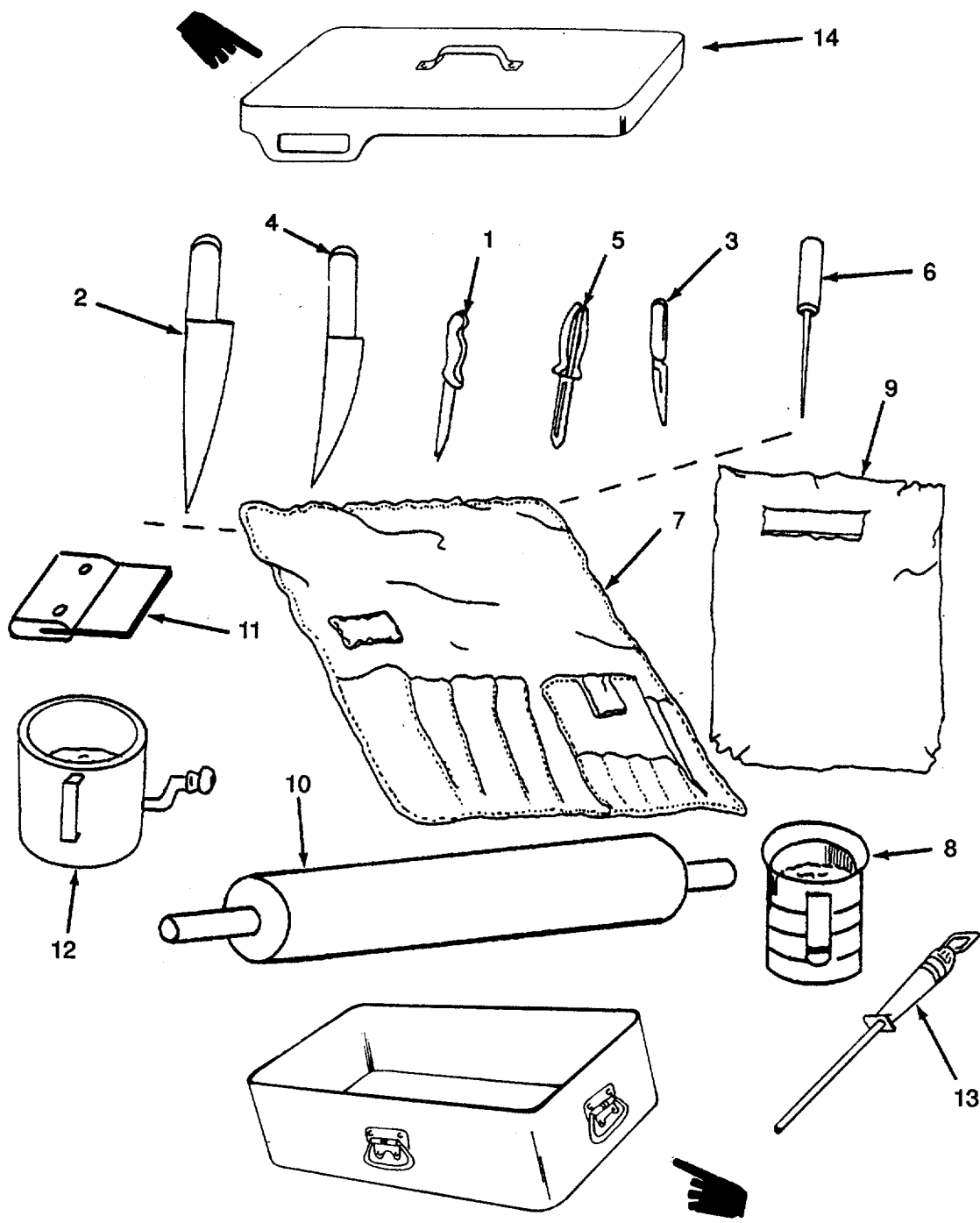

**2-9. PACKAGING (CONT).**

q. Roasting and Baking Pan (5 of 5) (Item 40. Appendix C). Insert the following and cover with roasting and baking pan cover (1), (Item 8A, Appendix C).

**NOTE**

Requires two persons to lift.

- (1) Two Mounted Can Openers (2)
- (2) One Fire Extinguisher (3)

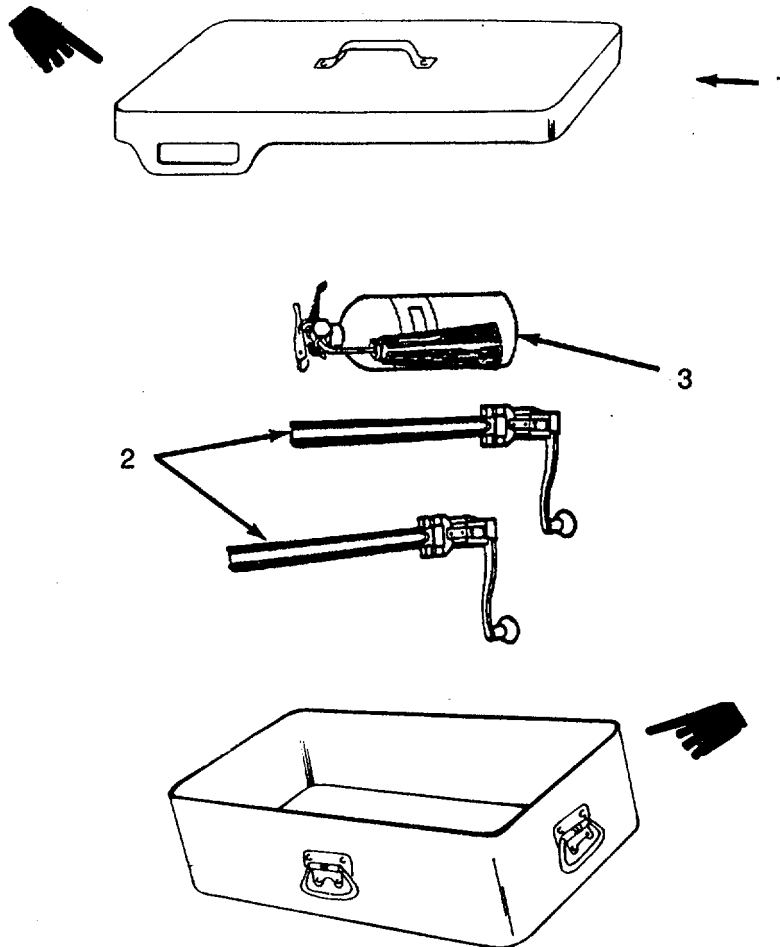

## Section IV. OPERATION UNDER UNUSUAL CONDITIONS

**2-10. GENERAL.** This section contains instructions for operation of the MFK in unusual environmental conditions of extreme cold, extreme heat, dusty or sandy areas, rainy and humid conditions, salt water areas, high altitudes, and under windy conditions. Refer to TM 10-7360-204-1 3&P, for M2 burner unit operation under unusual conditions.

### 2-11. OPERATION IN EXTREME COLD (BELOW 0°F/-18°C).

#### WARNING

**CARBON MONOXIDE GAS CAN KILL YOU.**

**THE BEST DEFENSE AGAINST CARBON MONOXIDE POISONING IS GOOD VENTILATION.**

- Carbon monoxide gas is not visible and has no smell, but it can kill you. Breathing air with carbon monoxide produces symptoms of headache, dizziness, loss of muscular control, a sleepy feeling, and coma. Brain damage or death can result from heavy exposure. Carbon monoxide occurs in exhaust fumes of fuel-burning equipment such as the M2 burner units. Carbon monoxide can become dangerously concentrated under conditions of no air movement. Precautions must be followed to ensure safety of personnel when you operate the M2 burner units. Open vents in the tent to provide ventilation and prevent the accumulation of carbon monoxide gas.
- Be **ALERT** at all times during MFK operation for symptoms of carbon monoxide exposure. **IMMEDIATELY VENTILATE** the tent. If symptoms persist, move affected personnel to fresh air and keep warm. **DO NOT PERMIT PHYSICAL EXERCISE.** If necessary, give artificial respiration.
- Operators be aware of signs of dangerous combustion products. Report any signs of headache, distress, dizziness, nausea and weakness.
- **FOR ARTIFICIAL RESPIRATION REFER TO FM 21-11.**
- Do not touch the MFK equipment metal parts when temperatures are below freezing without gloves, as injury may result.
- Wear protective clothing to prevent cold injuries.

#### NOTE

In extreme cold allow a longer period of time than normal to heat water to the desired temperature.

- a. Operate the M2 burner units in extreme cold conditions in accordance with TM 10-7360-204-13&P.
- b. Vent tent as often as possible. It is best to leave doors, windows, and roof vents open slightly. If this is not possible, open doors and roof vents periodically to remove stuffiness. At high altitudes do this more often. Operators should periodically leave the tent for a brief time.
- c. If eye, nose or throat irritation is noted vent the tent and adjust burners in accordance with TM 10-7360-204-13&P to obtain a greenish-colored flame.
- d. To reduce the environmental effects of extreme cold, use of the cold weather components shown in Appendix D, is recommended.



**2-12. OPERATION UNDER RAINY OR HUMID CONDITIONS.**

- a. When not in the tent, M2 burner units must be covered with canvas or other waterproof material. Remove the cover during dry periods, expose to open air, and allow units to dry.
- b. Operate the M2 burner units under rainy or humid conditions in accordance with TM 10-7360-204-13&P.

**2-13. OPERATION IN SALT WATER AREAS.**

- a. Keep equipment from contact with salt Water whenever possible. If contact is made, or if equipment is exposed to salt spray, wash equipment frequently with clean fresh water.
- b. Operate the M2 burner units in salt water areas in accordance with TM 10-7360-204-13&P.

**2-14. OPERATION AT HIGH ALTITUDES.**

Operate the M2 burner units at high altitudes in accordance with TM 10-7360-204-13&P.

**2-15. OPERATION IN WINDY CONDITIONS.**

- a. Whenever possible, take advantage of natural barriers to block the wind.
- b. Close the doors and windows of the tent on the windward side and open the tent on the leeward (downwind) side.
- c. Operate the M2 burner units in windy conditions in accordance with TM 10-7360-204-13&P.

**2-16. OPERATION IN EXTREME HEAT.**

**WARNING**

- Extreme heat will cause tank pressure to increase because of fuel expansion. Start with prescribed pressure in accordance with TM 10-7360-204-13&P.
  - Check air pressure frequently during burner unit operation.
  - Operators be aware of signs of heat stress. Use maximum ventilation. All windows, doors, and roof vents should be opened.
- a. Operate the M2 burner units in extreme heat in accordance with TM 10-7360-204-13&P.
  - b. The tent should have maximum ventilation. All windows, doors, and roof vents should be opened.

**2-17. OPERATION IN DUSTY OR SANDY AREAS.**

- a. Take advantage of any natural barriers that may be available when selecting the site.
- b. Where water is available, keep the immediate area wetted down. Keep all equipment as clean as possible.
- c. Keep dirt and grit out of the M2 burner unit fuel system and reserve fuel supply.
- d. Operate the M2 burner in dusty or sandy areas in accordance with TM 10-7360-204-13&P.



CHAPTER 3

OPERATOR'S MAINTENANCE INSTRUCTIONS

	SECTION/PARAGRAPH
Lubrication Instructions .....	I
General .....	3-1
Lubrication Procedures .....	3-2
Operator's Troubleshooting Procedures .....	II
General .....	3-3
M2 Burner Unit and Tent .....	3-4
Operator's Maintenance Procedures .....	III
General .....	3-5
Maintenance Procedure .....	3-6
Cleaning and Sanitation .....	3-7

## Section I. LUBRICATION INSTRUCTIONS

**3-1. GENERAL.** The MFK equipment has a limited number of moving parts that require lubrication. Perform these lubrication functions whenever equipment is being prepared for storage or the indicated parts are not moving freely. All specified lubrication materials are listed in Appendix E.

**3-2. LUBRICATION PROCEDURES.** The following lubrication instructions are mandatory.

a. Hinges. Lubricate hinges and handles on the heater tank, the storage cabinet, and the oven. Also lubricate the hinges on the food container with general purpose oil (Item 5, Appendix E).

b. Work Table. Lubricate linkage of each leg adapter and brace joint with general purpose oil (Item 5, Appendix E).

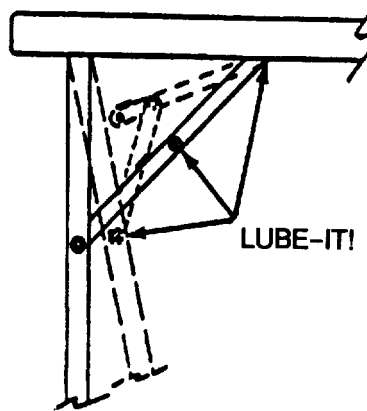

## Section II. OPERATOR'S TROUBLESHOOTING PROCEDURES

**3-3. GENERAL**

a. Table 3-1 lists common malfunctions that you may find during the operation or maintenance of the MFK or its components. Perform the tests and inspections and corrective actions in the order listed.

b. This manual cannot list all malfunctions that may occur nor all tests, inspections, or corrective actions. If a malfunction is either not listed or is not corrected by listed corrective actions, notify your supervisor.

**3-4. M2 BURNER UNIT AND TENT.** Perform operator's troubleshooting on the M2 burner units in accordance I with TM 10-7360-204-13&P. Refer to TM 10-8340-224-13 and perform operator troubleshooting for tent.

**Table 3-1. Operator's Troubleshooting**

<b>MALFUNCTION</b>	<b>TEST OR INSPECTION</b>	<b>CORRECTIVE ACTION</b>
<b>1. M2 BURNER UNIT DOES NOT HEAT FOOD SERVICE COMPONENTS PROPERLY.</b>	Step 1. Check to see if the M2 burner unit flame is on.	Light the M2 burner unit in accordance with TM 10-7360-204-13&P.
	Step 2. Check to see if M2 burner unit flame is green.	Adjust the M2 burner unit in accordance with TM 10-7360-204-13&P.
	Step 3. Check to see if the M2 burner unit flame is the proper height for the desired temperature.	Adjust the M2 burner unit for the temperature desired in accordance with TM 10-7360-204-13&P.
<b>2. WATER IN HEATER TANK DOES NOT DRAIN.</b>	Step 1. Observe water drainage and check for clogged drain.	Remove obstruction from tank-drain or drain hose. Thaw if frozen.
	Step 2. Check for excessive mud at drain hose output.	Relocate drain hose output end.
<b>3. WORK TABLE IS NOT STURDY.</b>	Step 1. Check table for proper locking of legs.	Lock properly (para 2-6j).
	Step 2. Check for bent or broken parts.	Notify Unit Maintenance.

**Section III. OPERATOR'S MAINTENANCE PROCEDURES**

**3-5. GENERAL.** This section contains operator's maintenance procedures for the MFK equipment.

**3-6. MAINTENANCE PROCEDURES.**

- a. Tent. Procedures to maintain the Tent, Extendable, Modular are contained in TM 10-8340-224-13&P.
- b. Lantern. Refer to FM 10-23.
- c. M2 Burner Unit. Procedures to maintain the M2 burner units are contained in TM 10-7360-204-13&P.

**3-7. CLEANING AND SANITATION.**

**WARNING**

Dry cleaning solvent A-A-711 TY1 (Item 4, Appendix E) used to clean parts, is potentially dangerous to personnel and property. Avoid repeated and prolonged skin contact. Do not use near open flame or excessive heat. Flash point of solvent is 1000 to 1380F (380 to 590C).

**CAUTION**

- Do not use abrasive cleaners or wire brushes on components or accessories. You may damage the finish.
  - Do not scour utensils; you may damage the finish.
- a. Clean storage rack, oven assembly, heater tank assembly, cooking pot cradle, work table, liquid dispensers, food containers, storage cabinet, and accessories such as the can opener and utensils with soap and warm water. Rinse with clean water and air dry.
  - b. Remove oven shelves for cleaning. Pull shelf half-way out and lift to overcome the stop.
  - c. Use a non-abrasive scouring pad (Item 6, Appendix E) for removing corrosion, burned-on food, or caked-on grease.
  - d. Check for signs of corrosion and peeling. The coating over the metal may show spots. Remove spots with soap and hot water or dry cleaning solvent AA-711 TY1 (Item 4, Appendix E) using a non-abrasive scouring pad.
  - e. After cleaning, check that all parts are secure.

**CHAPTER 4**  
**UNIT MAINTENANCE INSTRUCTIONS**

	SECTION/PARAGRAPH
Repair Parts, Special Tools, TMDE and Support Equipment .....	I
Common Tools and Equipment .....	4-1
Special Tools, Test, Measurement, and Diagnostic Equipment (TMDE), and Support Equipment.....	4-2
Repair Parts.....	4-3
Service Upon Receipt .....	II
Unpacking.....	4-4
Checking Unpacked Equipment .....	4-5
Unit Preventive Maintenance Checks and Services (PMCS) .....	III
General.....	4-6
Unit PMCS Procedures .....	4-7
Unit Troubleshooting .....	IV
General.....	4-8
Unit Maintenance Procedures .....	V
General.....	4-9
Repair of Storage Rack Assembly.....	4-10
Repair of Oven Assembly .....	4-11
Repair of Oven Door Assembly .....	4-12
Repair of Griddle Assembly .....	4-13
Repair of Steam Table Assembly .....	4-14
Repair of Heater Tank Assembly .....	4-15
Repair of Mounted Can Opener .....	4-16
Repair of Work Table.....	4-17
Repair of Insulated Liquid Dispenser .....	4-18
Repair of Food Container .....	4-19
Preparation for Storage or Shipment .....	VI
Administrative Storage .....	4-20
Preparation for Storage or Shipment .....	4-21
Packing for Shipment.....	4-22

**Section I. REPAIR PARTS, SPECIAL TOOLS, TMDE AND SUPPORT EQUIPMENT**

- 4-1. COMMON TOOLS AND EQUIPMENT.** Refer to your unit's Modified Table of Organization and Equipment, (MTOE) to determine the common tools and equipment authorized and available at your unit.
- 4-2. SPECIAL TOOLS, TEST, MEASUREMENT, AND DIAGNOSTIC EQUIPMENT (TMDE), AND SUPPORT EQUIPMENT.** The special tools required to maintain the MFK are listed in Appendix F, and Section III, Appendix B. No TMDE, or special support equipment is required at the unit level to maintain the MFK.
- 4-3. REPAIR PARTS.** Repair parts authorized for unit maintenance are listed in Appendix F.

**Section II. SERVICE UPON RECEIPT**

- 4-4. UNPACKING.** The MFK, with components, will be packaged in wooden crates strapped to wooden pallets. Check crates for indication of damage. Report any damage to your supervisor.

**CAUTION**

Unpack components carefully. Improper or hasty handling may result in damage to the MFK components and accessories.

- a. Procedure. Unpack the equipment in the following sequence:
- (1) Position crate or carton to be unpacked with the top facing up.
  - (2) Cut and remove retaining straps. Do not cut, rip, or otherwise damage packing material.
  - (3) Open the carton, remove the corrugated padding material, and set it aside.
  - (4) Lift the equipment from the carton.
- b. Shipping Material. Save the shipping carton and padding material for reuse.

**4-5. CHECKING UNPACKED EQUIPMENT.**

- a. Inspect the equipment for damage incurred during shipment. If the equipment has been damaged, report the damage on SF Form 364, Report of Discrepancy.
- b. Check the equipment against the packing slip to see if the shipment is complete. Report all discrepancies in accordance with the instructions of DA PAM 738-750.
- c. Check to see whether the equipment has been modified.



**Section III. UNIT PREVENTIVE MAINTENANCE CHECKS AND SERVICES (PMCS)**

**4-6. GENERAL PMCS** is performed upon receipt and quarterly thereafter. Record all defects found during the performance of PMCS and, if applicable, the steps taken to correct them, on DA Form 2404 Equipment Inspection and Maintenance Worksheet. Instructions for reporting/correcting noted deficiencies are contained in DA PAM 738-750.

**4-7. UNIT PMCS PROCEDURES.** Table 4-1 lists the specific PMCS that must be performed by unit maintenance personnel on a quarterly schedule.

a. Purpose. PMCS is done to ensure that the equipment is ready for use at all times and all deficiencies are corrected promptly. These checks and services are designed to help you find and correct defects before the equipment is damaged or fails to operate.

b. Item No. Column. Item numbers in the first column indicate the order in which things are to be done. Use the PMCS table item number column to get the numbers for the TM Item No. column of DA Form 2404 (Equipment Inspection and Maintenance Worksheet).

c. Item To Be Inspected/Serviced Column. A description of the item to be inspected or serviced.

d. Procedure Column. Procedure to be performed by unit maintenance personnel.

e. Equipment Not Ready/Available If Column. Contains the criteria that will cause the equipment to be classified as not ready/available because of inability to perform its combat mission.

Table 4-1. Unit Preventive Maintenance Checks and Services (PMCS) Quarterly Schedule

Item No.	Item To Be Inspected/Serviced	Procedure	Equipment Not Ready/Available if:
1	M2 Burner Unit	Refer to TM 10-7360-204-13&P	

**SECTION IV. UNIT TROUBLESHOOTING PROCEDURES**

**4-8. GENERAL.** Table 4-2 lists common malfunctions of the equipment and contains instructions for unit personnel to diagnose and correct each malfunction. Perform the indicated steps in the order listed.

**NOTE**

This manual cannot list all malfunctions that may occur. If a malfunction is either not listed or cannot be corrected by the indicated corrective actions, notify your supervisor.

Unit troubleshooting procedures for the M2 burner unit are outlined in TM 10-7360-204-13&P.

Table 4-2. Unit Troubleshooting

MALFUNCTION	TEST OR INSPECTION	CORRECTIVE ACTION
<b>1. OVEN ASSEMBLY DOES NOT HEAT PROPERLY.</b>	Step 1. Check that vent passage is clear.	Clear vent passage. If necessary replace vent cap(s) as described in paragraph 4-11.
	Step 2. Check oven door gasket.	Replace if necessary as described in paragraph 4-12.
	Step 3. Check base insulation.	Replace if necessary as described in paragraph 4-11. If problem still exists, notify direct support maintenance.
<b>2. FOOD STICKS ON GRIDDLE SURFACE.</b>	Inspect condition of griddle surface.	If anodized surface is badly scratched or worn off (over 50% on both surfaces), replace griddle, as described in paragraph 4-13.
<b>3. STEAM TABLE ASSEMBLY DOES NOT HOLD WATER.</b>	Step 1. Check the condition of the drain stopper assembly.	If replacement is necessary, notify direct support maintenance.
	Step 2. Check for water leaking from bottom or sides.	If leak is found and welding is required, notify direct support maintenance.
<b>4. HEATER TANK DOES NOT HOLD WATER.</b>	Step 1. Check to see that the drain valve or drain hose is not leaking.	If leaking, replace the drain hose or drain valve as described in paragraph 4-15.
	Step 2. Check for water leaking from the sides or bottom of the cabinet.	If leak is found and welding is required, notify direct support maintenance.

Table 4-2. Unit Troubleshooting (Cont)

MALFUNCTION	TEST OR INSPECTION	CORRECTIVE ACTION
<b>5. HEATER TANK ASSEMBLY HANDLES OR CATCHES MALFUNCTION.</b>	Check to see if the handle or catches are bent or broken.	If bent or broken, replace the catch or handle as described in paragraph 4-15.
<b>6. MOUNTED CAN OPENER DOES NOT CUT.</b>	Check for dull blades.	Replace blades per paragraph 4-16.
<b>7. LIQUID DISPENSER LEAKS OR DOES NOT KEEP BEVERAGE AT PROPER TEMPERATURE.</b>	Check and inspect the latch assembly, lid gasket, lid assembly, vent assemblies, and faucet assemblies.	Replace faulty items as described in paragraph 4-18.
<b>8. FOOD CONTAINER DOES NOT KEEP FOOD AT PROPER TEMPERATURE.</b>	Check and inspect the hinge assembly, gasket and latch assembly.	Replace defective items as described in paragraph 4-19.
<b>9. STORAGE CABINET DOOR DOES NOT OPEN OR CLOSE PROPERLY.</b>	Check for obstruction, warped door, damaged catch and hook	Notify direct support maintenance.
<b>10. STORAGE CABINET HANDLE IS LOOSE.</b>	Check handle mounting hardware.	Notify direct support maintenance.

## Section V. UNIT MAINTENANCE PROCEDURES

**4-9. GENERAL**

a. This section contains unit maintenance procedures as authorized by the Maintenance Allocation Chart (MAC), Appendix B of this manual. The following topics are included as applicable: a Remove, b. Repair, c. Replace. All maintenance procedures in this section will be performed by one person unless otherwise indicated in the initial setup.

b. Read all warnings, cautions, notes and instructions carefully before operating or working on this unit. Read and understand all warnings listed in the front of this manual.

c. Refer to TM 10-8340-224-13 for maintenance procedures on tent.

d. Refer to TM 10-7360-20413&P for maintenance procedures on M2 burner unit.

**4-10. REPAIR OF STORAGE RACK ASSEMBLY.**INITIAL SETUP

## Tools

General Mechanic's Tool Kit (Item 1, Section III, Appendix B)

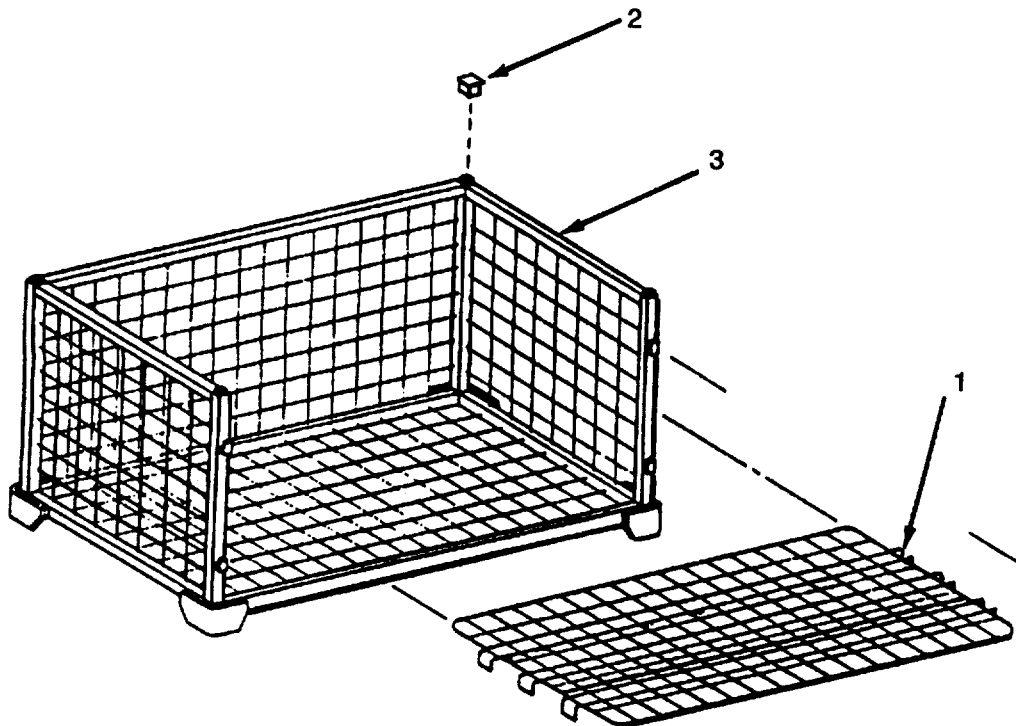
REMOVAL AND REPLACE

1. Remove and replace defective or missing shelf/cover (1).
2. Remove and replace defective or missing tube plug (2).
3. Replace defective storage rack (3).

4-11. REPAIR OF OVEN ASSEMBLY.

INITIAL SET UP

Tools

General Mechanic's Tool Kit (Item 1, Section III, Appendix B)

Materials/Parts

Locknuts

Personnel Required - Two

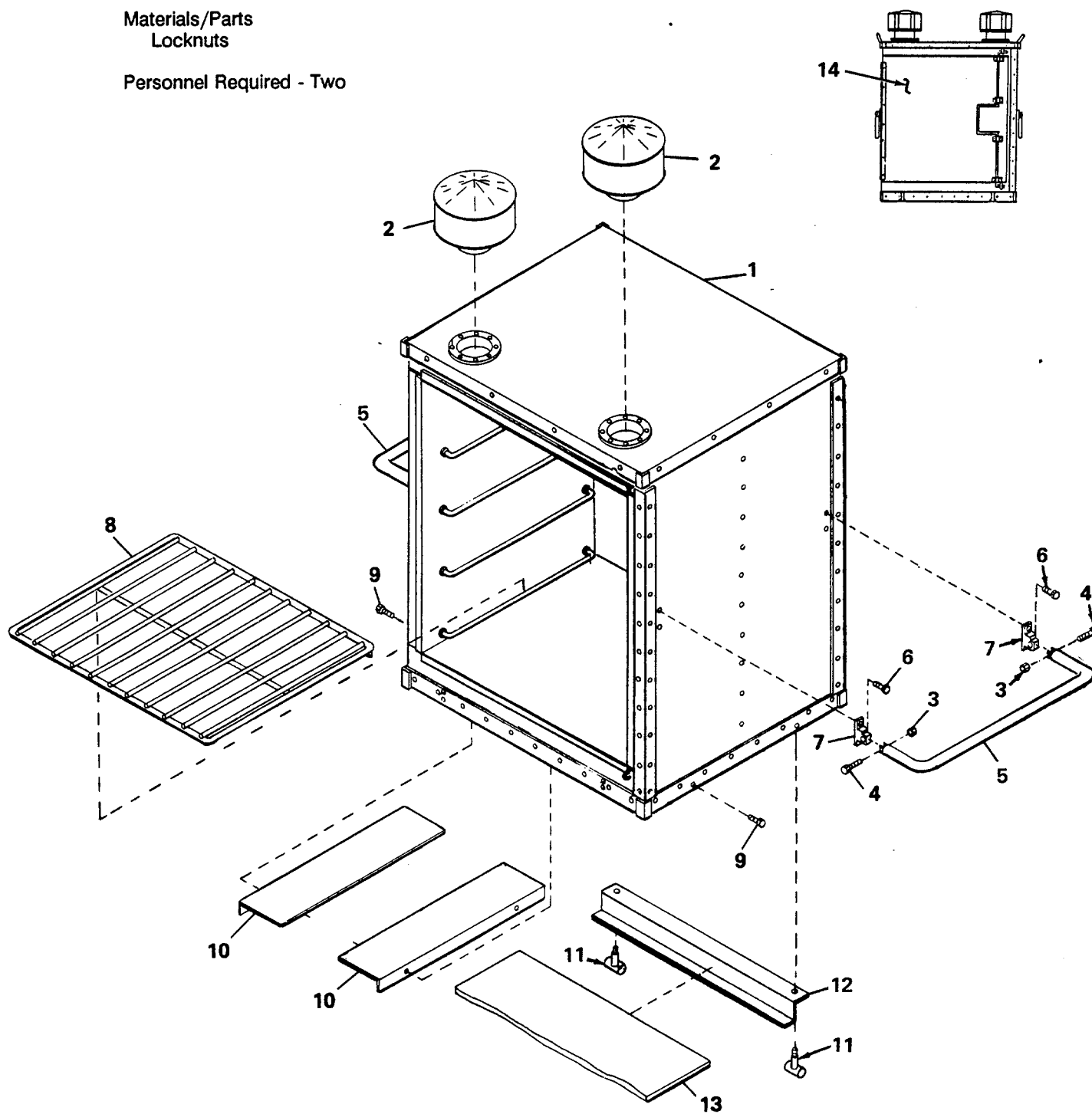

**4-11. REPAIR OF OVEN ASSEMBLY (CONT).****REMOVAL**

1. Pull up and remove vent caps (2) from oven assembly (1).
2. Remove four locknuts (3) and screws (4) to remove two carrying handles (5).
3. Remove eight screws (6) to remove four handle holders (7).
4. Open door (14) and remove oven racks (8).
5. Tilt back the oven assembly so it lays on its back side (oven door (14) up).
6. Remove four screws (9) and deflectors (10).
7. Remove two T-bolts (11) that hold insulation bracket (12).
8. Pull-out the insulation (13) to release it from the lip at the top of the frame.

**REPLACE**

1. Place the top of the insulation (13) under the lip of the frame while carefully pushing up.
2. Install insulation bracket (12) with two T-bolts (11).
3. Install deflectors (10) with four screws (9).
4. Bring the oven assembly into an upright position.
5. Open door to slide-in oven rack (8).
6. Install four handle holders (7) with eight screws (6).
7. Install two carrying handles (5) with four locknuts (3) and screws (4).
8. Push-in two vent caps (2) into position on top of oven assembly (1).

**4-12. REPAIR OF OVEN DOOR ASSEMBLY.****INITIAL SETUP**

## Tools

General Mechanic's Tool Kit (Item 1, Section III, Appendix B)

## Material/Parts

Gasket (Item 1, Appendix G)

Adhesive (Item 1, Appendix E)

## Equipment Condition

Oven door assembly open.

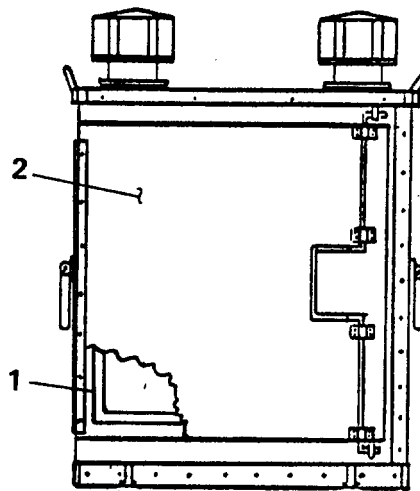
**REMOVAL AND REPLACE**

1. Remove door gasket (1) from inside of oven door assembly (2).
2. Ensure area for new gasket is clean of old gasket material.
3. Measure and cut to size gasket bulk material.
4. Adhere door gasket (1) to inside of oven door assembly (2) with adhesive.
5. Ensure adhesive is thoroughly dry before oven is heated.

4-13. REPAIR OF GRIDDLE ASSEMBLY.

INITIAL SETUP

Tools

General Mechanic's Tool Kit (Item 1, Section III, Appendix B)

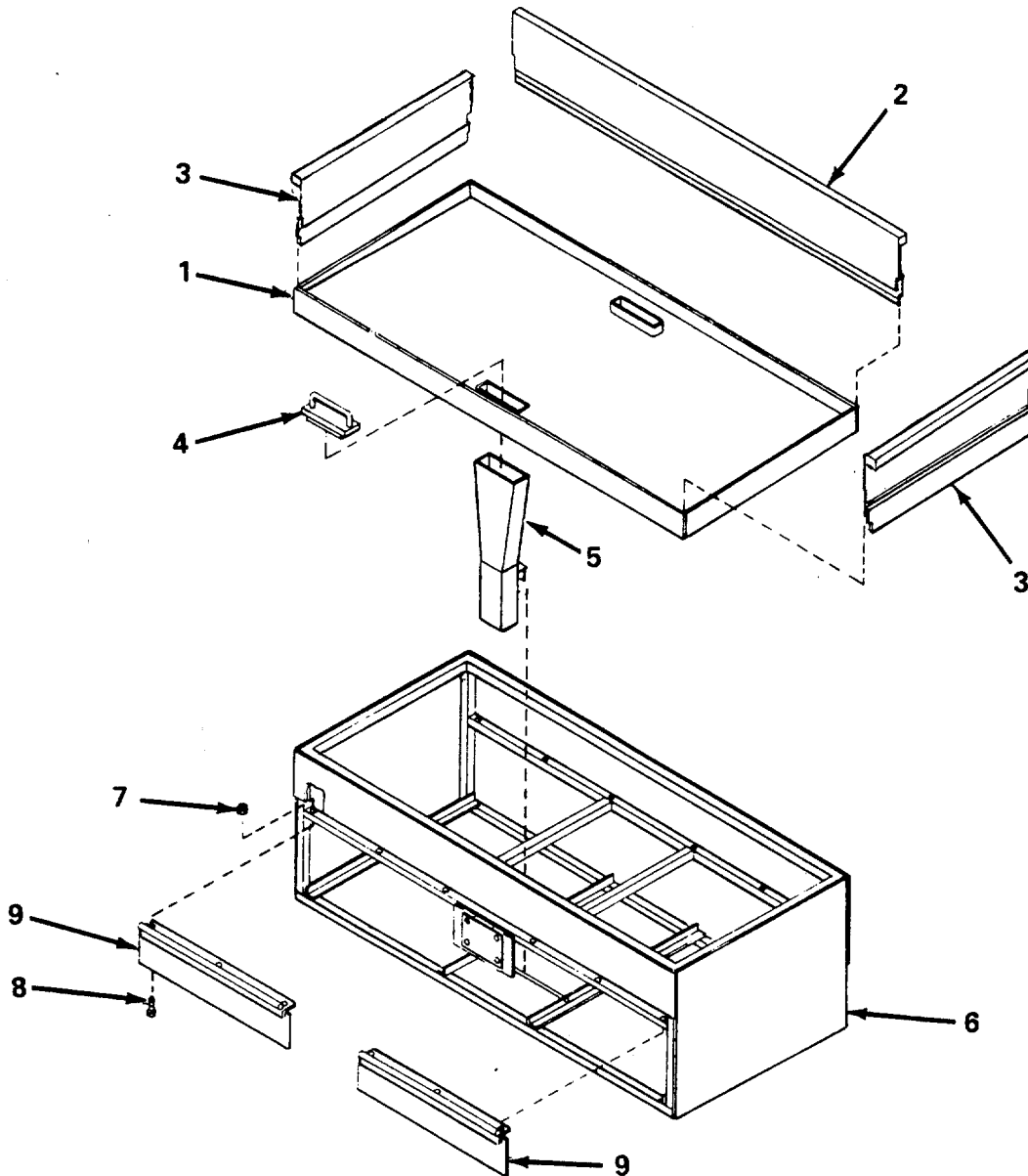



**4-13. REPAIR OF GRIDDLE ASSEMBLY (CONT).****REMOVAL**

1. Pull the long splash guard (2) and short splash guards (3) up and off the griddle (1).
2. Remove the grease slot plug (4).
3. Unhook the grease chute (5) from the center member of the double burner rack (6). Pull the grease chute (5) downward and out of the griddle top grease slot.
4. Lift griddle (1) off of double burner rack (6).
5. Remove six nuts (7) and six screws (8) to remove two heat guards (9).

**REPLACE**

1. Install two heat guards (9) with six nuts (7) and six screws (8).
2. Assemble griddle (1) on to double burner rack (6).
3. Hook on the grease chute (5) to the center member of the double burner rack (6). Push the grease chute (5) upward into griddle top grease slot.
4. Install grease slot plug (4).
5. Install splash guards (2) and (3) onto griddle (1).

**4-14. REPAIR OF STEAM TABLE ASSEMBLY.**

INITIAL SET-UP

Tools

- General Mechanic's Tool Kit (Item 1, Section III, Appendix B)
- Wrench, Adjustable (Item 10, Section III, Appendix B)
- Wrench, Pipe (Item 12, Section III, Appendix B)

Material/Parts

- Sealing Compound (Item 7, Appendix E).

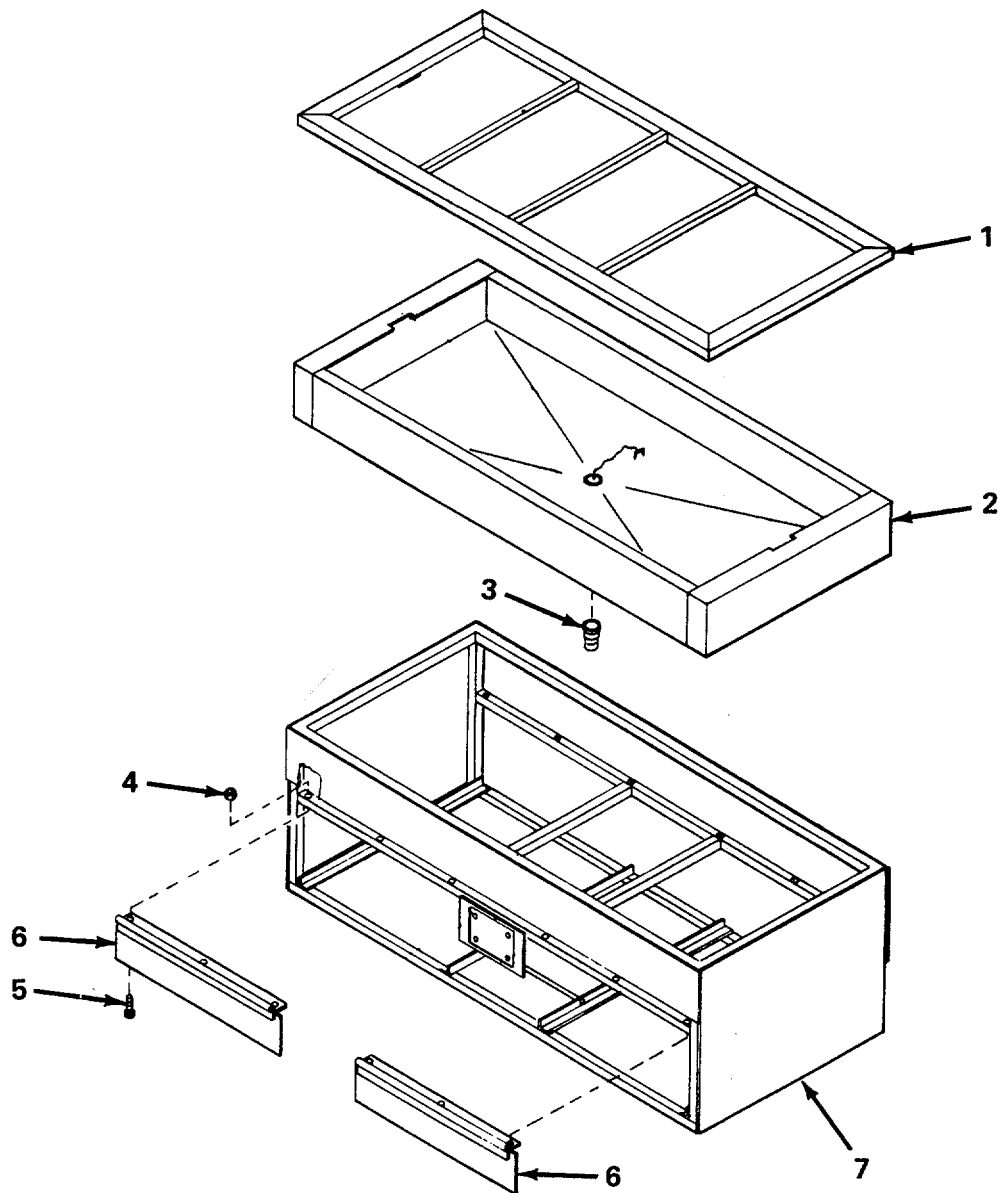

**4-14. REPAIR OF STEAM TABLE ASSEMBLY (CONT).****REMOVAL**

1. Lift top adapter (1) off of double burner rack (7).
2. Lift up and remove steam table body (2).
3. Unscrew half coupling (3) from steam table body (2).
4. Remove six nuts (4) and six screws (5) to remove two heat guards (6).

**REPLACE**

1. Install two heat guards (6) with six nuts (4) and six screws (5).
2. Place sealing compound on half coupling (3) threads.
3. Thread half coupling (3) on to steam table body (2).
4. Install steam table body (2) and top adapter (1) on to double burner rack (7).

**4-15. REPAIR OF HEATER TANK ASSEMBLY.**

INITIAL SET-UP

Tools

General Mechanic's Tool Kit (Item 1, Section III, Appendix B)

Material/Parts

Sealing Compound (Item 7, Appendix E)

Locknuts

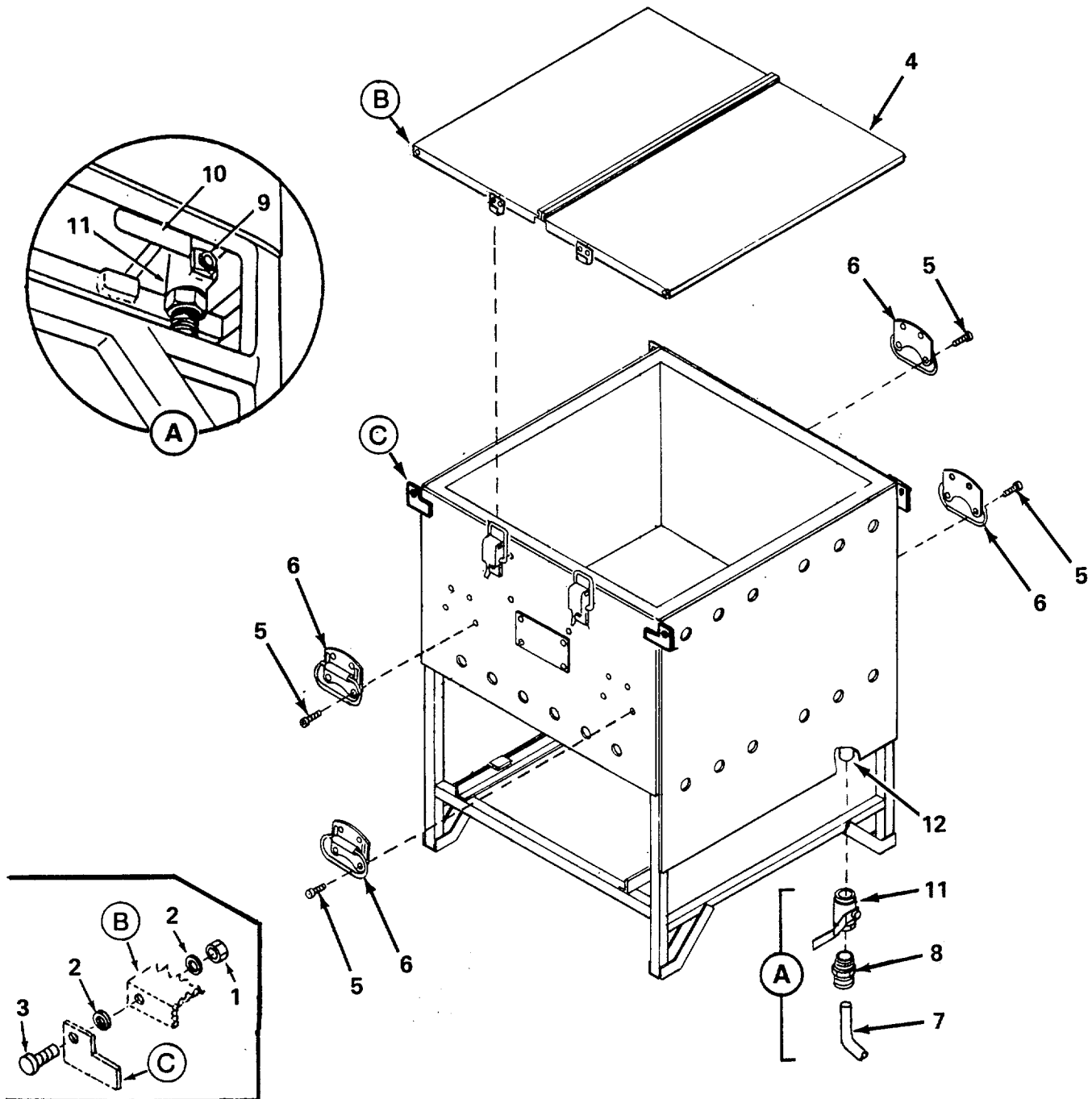

**4-15. REPAIR OF HEATER TANK ASSEMBLY (CONT).****REMOVAL**Cover and Handles

1. Remove four nuts (1), eight flat washers (2), and four screws (3) attaching cover (4).
2. Remove five screws (5) to remove each handle (6).

Ball Valve

1. If connected, unscrew drain hose (7) from pipe-to-hose adapter (8).
2. Remove nut (9) and handle (10) from ball valve (11).
3. Unscrew pipe-to-hose adapter (8) from ball valve (11).
4. Unscrew ball valve (11) from drain pipe (12).

**REPLACE**Cover and Handles

1. Install four nuts (1), eight flat washers (2), and four screws (3), to attach cover (4).
2. Install five screws (5) to attach each handle (6).

Ball Valve

1. Remove nut (9) and handle (10) from new ball valve (11).
2. Place sealing compound on threads to ensure leakproof seal.
3. Thread ball valve (11) on drain pipe (12).
4. Install handle (10) and nut (9) to ball valve (11).
5. Use sealing compound as above, and thread pipe-to-hose adapter (8) to ball valve (11).
6. Thread drain hose (7) on the pipe-to-hose adapter (8).

**4-16. REPAIR OF MOUNTED CAN OPENER.**INITIAL SET-UP

## Tools

General Mechanic's Tool Kit  
(Item 1, Section III, Appendix B)

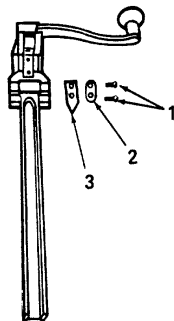
**REMOVAL**

Remove two screws (1),  
I support plate (2) and blade (3).

**REPLACE**

1. Install blade (3) and I support plate (2).
2. Install and tighten two screws (1).

**4-17. REPAIR OF WORK TABLE.****INITIAL SETUP**

## Tools

General Mechanic's Tool Kit (Item 1, Section III, Appendix B)

## Material/Parts

Lockwasher

General Purpose Lubricating Oil (Item 5, Appendix E)

**NOTE**

- If table hinges are bent or difficult to use, repair by straightening hinge link with hand tools.
- Lubricate friction areas, if necessary with general purpose lubricating oil.

**REMOVAL**

1. Remove eight nuts (2) and lockwashers (3).
2. Remove table leg (4) from table top (1).

**REPLACE**

1. Install table leg (4) on table top (1).
2. Install eight lock lockwashers (3) and nuts (2) on studs and tighten.

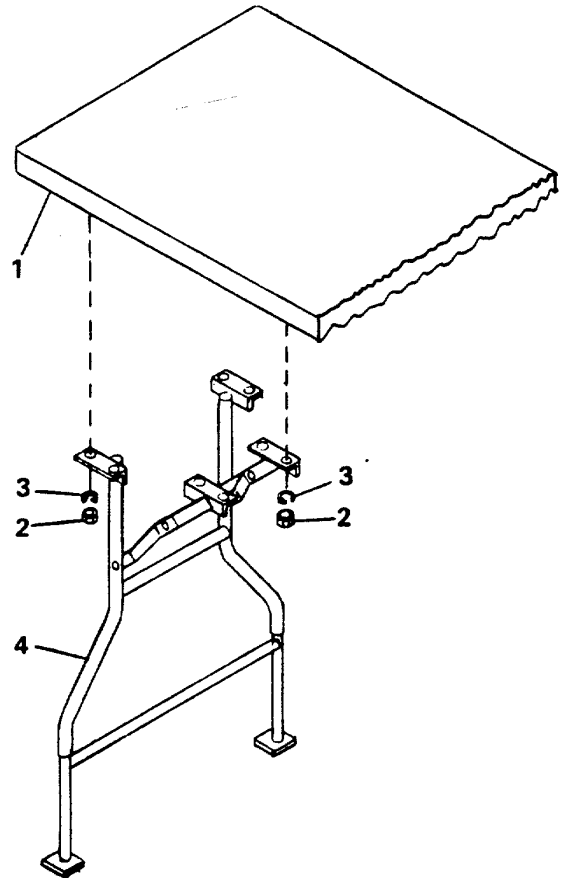

**4-18. REPAIR OF INSULATED LIQUID DISPENSER.**

**INITIAL SETUP**

**Tools**

General Mechanic's Tool Kit (Item 1, Section III, Appendix B)

**a. Vent Cap**

- (1) Remove

Remove vent cap (1) from lid (2).

- (2) Replace

Install vent cap (1) on lid (2).

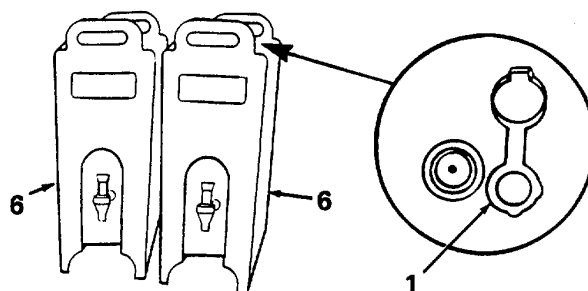

**b. Lid Gasket**

- (1) Remove

Remove gasket (3) from lid (2).

- (2) Replace

Install gasket (3) on lid (2).

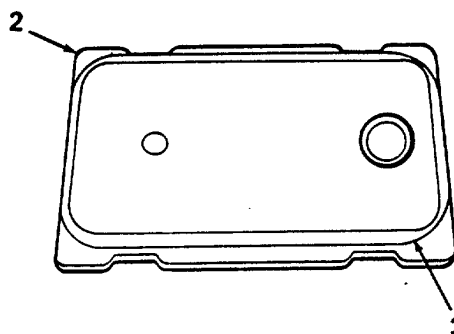

**c. Latch Assembly**

- (1) Remove

- (a) Remove two screws (4).

- (b) Remove latch assembly (5).

- (2) Replace

- (a) Align latch assembly (5) with two holes in insulated liquid dispenser (6).

- (b) Install and tighten two screws (4).

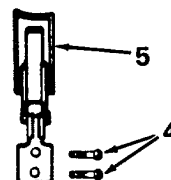

<b>4-18. REPAIR OF INSULATED LIQUID DISPENSER (CONT).</b>
---

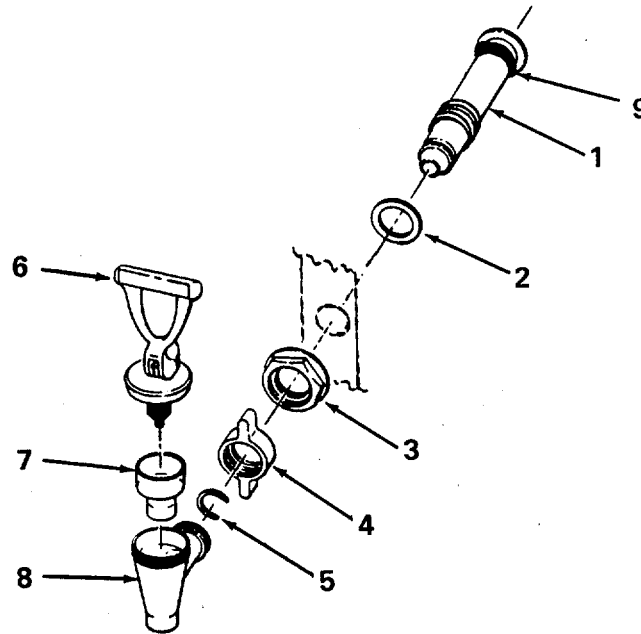
d. Faucet Assembly and Spout Assembly.

<b>REMOVAL</b>
----------------

1. Loosen cap (6) from top of faucet (8) and remove silicone rubber seat cup (7).
2. Loosen wing nut (4) and remove faucet (8) from spout (1).
3. Remove C nut (5) and wing nut (4) from spout (1).
4. Remove hex nut (3), spout (1) and preformed packing (2).

<b>REPLACE</b>
----------------

1. Install spout (1) and preformed packing (2) from the inside through dispenser wall. Ensure gasket (9) is in place.
2. Replace hex nut (3) and tighten.
3. Install wing nut (4) and C nut (5) on spout (1).
4. Install silicone rubber seal cup (7) and install cap (6) on faucet (8) and tighten.
5. Install faucet (8) to spout (1) and tighten wing nut (4).



**4-19. REPAIR OF FOOD CONTAINER.****INITIAL SET-UP**

## Tools

General Mechanic's Tool Kit (Item 1, Section III, Appendix B)

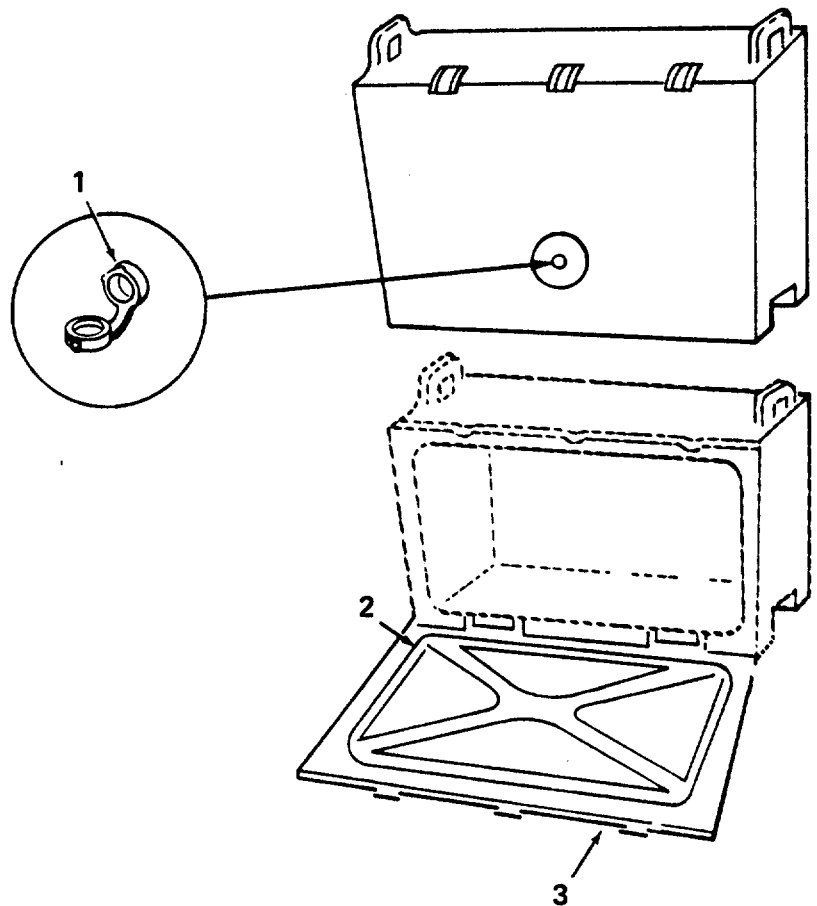
a. Vent Cap

## (1) Removal

Remove vent cap (1) from door (3).

## (2) Replace

Install vent cap (1) on door (3).

b. Door Gasket

## (1) Removal

Remove gasket (2) from door (3).

## (2) Replace

Install gasket (2) on door (3).

**4-19. REPAIR OF FOOD CONTAINER (CONT).****c. Latch Assembly****(1) Removal**

- (a) Remove two screws (1).
- (b) Remove latch assembly (2).

**(2) Replace**

- (a) Align latch assembly (2) with holes in food container (3).
- (b) Install and tighten two screws (1).

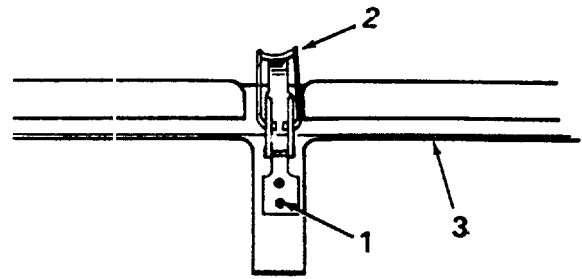
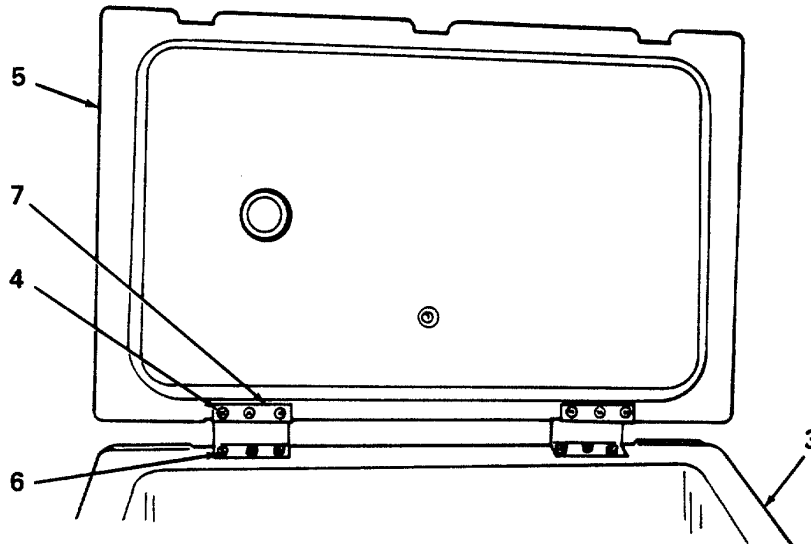
**d. Hinge Assembly****(1) Removal**

- (a) Remove six screws (4) from door (5) and remove door (5).
- (b) Remove six screws (6) from food container (3) and remove hinges (7).

**(2) Replace**

- (a) Align hinges (7) with holes in food container (3).
- (b) Install six screws (6).
- (c) Align hinges (7) with holes in door (5).
- (d) Install six screws (4).
- (e) Adjust door (5) to food container (3) for good fit and tighten screws.

**SECTION VI. PREPARATION FOR STORAGE OR SHIPMENT****4-20. ADMINISTRATIVE STORAGE.**

a. Placement of equipment in administrative storage should be for short periods of time when a shortage of maintenance effort exists. Items should be in mission readiness within 24 hours or within the time factors as determined by the directing authority. During the storage period appropriate maintenance records will be kept.

b. Before placing equipment in administrative storage, Preventive Maintenance Checks and Services (PMCS) should be completed, shortcomings and deficiencies should be corrected, and all Modification Work Orders (MWO's) should be applied.

c. Storage site selection. Inside storage is preferred for items selected for administrative storage. If inside storage is not available, trucks, vans, convex containers and other containers may be used.

**4-21. PREPARATION FOR STORAGE OR SHIPMENT.** Prepare the equipment for movement as described in paragraph 28. Preservation, packaging, and packing of military supplies and equipment are described in TM 38-230-2.

Storage.**NOTE**

Be sure the storage location is on firm, level ground and at a well drained site.

Store the equipment in a building, shed, or under cover. If the equipment is to be stored outside, place on a pallet or planking; place a canvas tarp or waterproof cover over it.

**4-22. PACKING FOR SHIPMENT.** If available, use packing materials and shipping cartons in which the equipment was received, or similar material.



CHAPTER 5

DIRECT SUPPORT MAINTENANCE INSTRUCTIONS

SECTION/PARAGRAPH

GENERAL ..... I  
    Scope of Direct Support Maintenance ..... 3-1  
DIRECT SUPPORT MAINTENANCE PROCEDURES ..... II  
    Rivet Removal ..... 5-2  
    Rivet Replacement ..... 5-3  
    Welding ..... 5-4

SECTION I. GENERAL

**5-1. SCOPE OF DIRECT SUPPORT MAINTENANCE.** Direct support maintenance identified in Appendix B consists of repairing or replacing components that are riveted or welded. Refer to TC 9-510 for information on I metal body repairs. Direct support maintenance of the Tent, Extended Modular is covered in TM 10-8340-224-13.

SECTION II. DIRECT SUPPORT MAINTENANCE PROCEDURES

**5-2. RIVET REMOVAL.** Remove rivets as shown below:

**CAUTION**

When removing rivets, do not increase the size of the original rivet hole so that the original rivet requires replacement with a larger rivet.

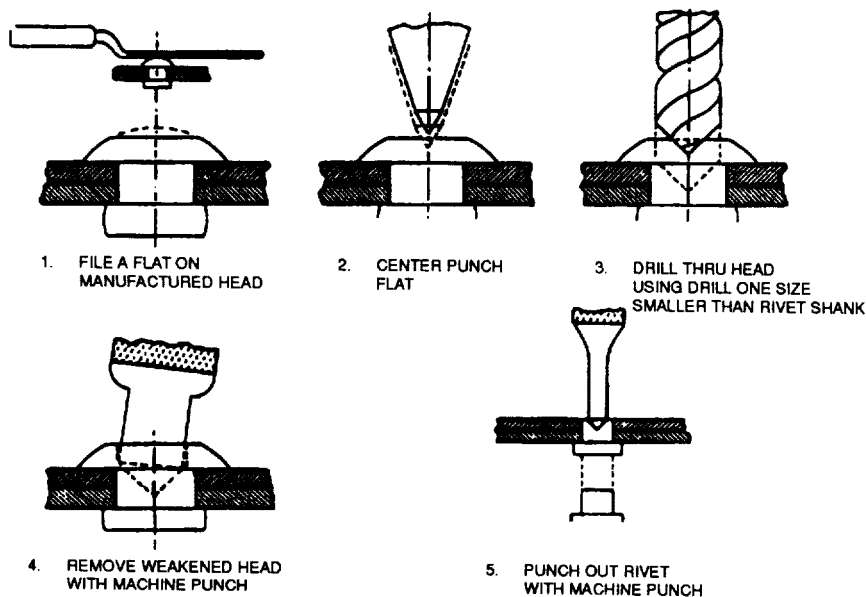

**5.3. RIVET REPLACEMENT.**

a. Procedure.

- (1) Check for evidence of loose or working rivets and mark all of those for replacement.

**NOTE**

A working rivet has movement under structural stress, but has not loosened so much that you can see movement. This condition can sometimes be detected by a dark, greasy residue or damage to paint and primers around rivet heads.

- (2) Where possible, replace rivets with the same type as originally used.

### 5-3. RIVET REPLACEMENT (CONT).

(a) The rivet code designation gives the type of rivet, the material, the diameter in 32nds of an inch, and the length in 16ths of an inch.

(b) The determination of the length of a rivet is an important part of any repair. The length used depends on the grip or combined thickness of material to be riveted plus a minimum allowance of 1/2 diameter for upsetting the shank.

(c) Always use the nearest standard rivet length greater than the calculated sum.

(3) There are specific considerations in laying out the rivet pattern for a repair; these rules apply generally in all instances.

(a) When possible, rivet edge distance, rivet spacing, and distance between rows should be the same as that of the original installation.

(b) When new sections are added, the edge distance measured from the center of the rivet should never be less than two times the diameter of the shank. The distance between rivets or pitch should be at least three times the diameter; the distance between rows should never be less than 1/2 times the diameter.

(c) Mark the rivet pattern on the metal with a soft pencil to avoid scratching.

(4) Rivet holes may be drilled with either a light power drill or a hand drill (standard shank twist drill).

(a) Before drilling, center-punch all rivet locations. The center-punch mark should be large enough to prevent the drill from slipping out of position.

(b) Place drill in center-punch mark. When using a power drill, rotate the bit a few turns by hand before starting motor. While drilling, always hold drill at a 90-degree angle to work.

(c) Avoid excessive pressure; let the drill do the cutting. Never push drill through stock. Remove all burrs with a metal countersink or file.

(d) Transfer holes from drilled part to another part by placing second part over first and using established holes as a guide.

(e) After drilling and before you drive rivets, the metal sheets must be held securely in position to prevent slippage during riveting. When two pieces of metal have been drilled through, use any of several types of available skin fasteners to hold them in alignment.

**5-4. WELDING.** MFK components such as the storage rack assembly, oven assembly, burner and base racks, steam table assembly, heater tank assembly, cooking pot cradle assembly and work tables may require welding. Refer to TM 9-237 for information on welding theory and application.





APPENDIX A

REFERENCES

A-1. SCOPE. This appendix lists all forms, pamphlets, field manuals, technical manuals, Army Regulations, military specifications, and military standards referenced in the manual.

A-2. FORMS

Equipment Inspection and Maintenance Worksheet ..... DA Form 2404  
 Report of Discrepancy ..... SF Form 364  
 Product Quality Deficiency Report ..... SF 368  
 Recommended Changes to Equipment Technical Publications ..... DA Form 2028-2

A-3. FIELD MANUALS

Army Troop Feeding Operations ..... FM 10-23  
 First Aid for Soldiers ..... FM 21-11  
 Unit Field Sanitation Team ..... FM 21-10-1  
 Field Water Supply ..... FM 10-52

A-4. TECHNICAL MANUALS

Operator, Organizational and Direct Support Maintenance Manual Including Repair Parts and Special  
 Tools List for Can, Gasoline, 5-Gallon ..... TM 10-7200-200-13  
 Metal Body Repairs and Related Operations ..... TC 9-510  
 Operator, Organizational and Direct Support Maintenance Manual Including Repair Parts and Special  
 Tools List for Range Outfit, Field Gasoline, Model M59 ..... TM 10-7360-204-13&P  
 Operator, Unit and Direct Support Maintenance Manual Including Repair Parts and Special  
 Tools List for Food Sanitation Center ..... TM 10-7360-211-13&P  
 Operator, Organizational and Direct Support Maintenance Manual Including Repair Parts and  
 Special Tools List for Tent, Extendable, Modular  
 (16 x 20 Utility) (NSN 8340-01-185-2613) ..... TM 10-8340-224-13 E  
 Procedure for Destruction of Equipment to Prevent Enemy Use ..... TM 750-224-3  
 Welding Theory and Application ..... TM 9-237  
 Preservation, Packaging, Packing of Military Supplies and Equipment ..... TM 38-230-2

A-5. MISCELLANEOUS

Consolidated Index of Army Publications and Blank Forms ..... DA PAM 25-30  
 The Army Maintenance Management System (TAMMS) ..... DA PAM 738-750  
 Occupational and Environmental Health Food Service Sanitation ..... TB Med 530



**APPENDIX B****MAINTENANCE ALLOCATION CHART (MAC)****SECTION I. INTRODUCTION****B-1. THE ARMY MAINTENANCE SYSTEM MAC**

This introduction provides a general explanation of all maintenance and repair functions authorized at the two maintenance levels under the Two-Level Maintenance System concept.

This MAC (immediately following the introduction) designates overall authority and responsibility for the performance of maintenance functions on the identified end item or component. The application of the maintenance functions to the end item or component levels, which are shown on the MAC in column (4) as:

Field - includes two columns, Unit Maintenance and Direct Support maintenance. The Unit maintenance column is divided again into two more subcolumns, C for Operator or Crew and O for Unit maintenance.

Sustainment – includes two subcolumns, general support (H) and depot (D).

The tools and test equipment requirements (immediately following the MAC) list the tools and test equipment (both special tools and common tool sets) required for each maintenance function as referenced from the MAC.

The remarks (immediately following the tools and test equipment requirements) contain supplemental instructions and explanatory notes for a particular maintenance function.

**B-2. MAINTENANCE FUNCTIONS**

Maintenance functions will be limited to and are defined as follows:

1. Inspect. To determine the serviceability of an item by comparing its physical, mechanical, and/or electrical characteristics with established standards through examination (e.g., by sight, sound, or feel.) This includes scheduled inspection and gagings and evaluation of cannon tubes.
2. Test. To verify serviceability by measuring the mechanical, pneumatic, hydraulic, or electrical characteristics of an item and comparing those characteristics with prescribed standards on a scheduled basis, i.e., load testing of lift devices and hydrostatic testing of pressure hoses.
3. Service. Operations required periodically to keep an item in proper operating condition; e.g., to clean (includes decontaminate, when required), to preserve, to drain, to paint, or to replenish fuel, lubricants, chemical fluids, or gases. This includes scheduled exercising and purging of recoil mechanisms. The following are examples of service functions:
  - a. Unpack. To remove from packing box for service or when required for the performance of maintenance operations.
  - b. Repack. To return item to packing box after service and other maintenance operations.
  - c. Clean. To rid the item of contamination.

- d. Touch up. To spot paint scratched or blistered surfaces.
  - e. Mark. To restore obliterated identification.
4. Adjust. To maintain or regulate, within prescribed limits, by bringing into proper position, or by setting the operating characteristics to specified parameters.
  5. Align. To adjust specified variable elements of an item to bring about optimum or desired performance
  6. Calibrate. To determine and cause corrections to be made or to be adjusted on instruments of test, measuring, and diagnostic equipment used in precision measurement. Consists of comparisons of two instruments, one of which is a certified standard of known accuracy, to detect and adjust any discrepancy in the accuracy of the instrument being compared.
  7. Remove/install. To remove and install the same item when required to perform service or other maintenance functions. Install may be the act of emplacing, seating, or fixing into position a spare, repair part, or module (component or assembly) in a manner to allow the proper functioning of an equipment or system.
  8. Paint. To prepare and spray color coats of paint so that the ammunition can be identified and protected. The color indicating primary use is applied, preferably, to the entire exterior surface as the background color of the item. Other markings are to be repainted as original so as to retain proper ammunition identification.
  9. Replace. To remove an unserviceable item and install a serviceable counterpart in its place. "Replace" is authorized by the MAC and assigned maintenance level is shown as the third position code of the Source, Maintenance and Recoverability (SMR) code.
  10. Repair. The application of maintenance services, including fault location/troubleshooting, removal/installation, disassembly/assembly procedures and maintenance actions to identify troubles and restore serviceability to an item by correcting specific damage, fault, malfunction, or failure in a part, subassembly, module (component or assembly), end item, or system.

### NOTE

The following definitions are applicable to the "repair" maintenance function: Services. Inspect, test, service, adjust, align, calibrate, and/or replace.

Fault location/troubleshooting. The process of investigating and detecting the cause of equipment malfunctioning; the act of isolating a fault within a system or Unit Under Test (UUT).

Disassembly/assembly. The step- by- step breakdown (taking apart) of a spare/functional group coded item to the level of its least component, that is assigned an SMR code for the level of maintenance under consideration (i.e. identified as maintenance significant).

Actions. Welding, grinding, riveting, straightening, facing, machining, and/or resurfacing.

11. Overhaul. That maintenance effort (service/action) prescribed to restore an item to a completely serviceable/operational condition as required by maintenance standards in appropriate technical publications. Overhaul is normally the highest degree of maintenance performed by the Army. Overhaul does not normally return an item to like new condition.
12. Rebuild. Consists of those services/actions necessary for the restoration of unserviceable equipment to a like new condition in accordance with original manufacturing standards. Rebuild is the highest degree of material maintenance applied to Army equipment. The rebuild operation includes the act of returning to zero those age measurements (e.g., hours/miles.) considered in classifying Army equipment/components.

**B-3. EXPLANATION OF COLUMNS IN THE MAC, SECTION II**

Column (1) Group Number. Column (1) lists Functional Group Code (FGC) numbers, the purpose of which is to identify maintenance significant components, assemblies, subassemblies, and modules with the Next Higher Assembly (NHA).

Column (2) Component/Assembly. Column (2) contains the names of components, assemblies, subassemblies, and modules for which maintenance is authorized.

Column (3) Maintenance Function. Column (3) lists the functions to be performed on the item listed in column (2). (For detailed explanation of these functions refer to "Maintenance Functions" outlined above).

Column (4) Maintenance Level. Column (4) specifies each level of maintenance authorized to perform each function listed in column (3), by indicating work time required (expressed as man-hours in whole hours or decimals) in the appropriate subcolumn. This work time figure represents the active time required to perform that maintenance function at the indicated level of maintenance. If the number or complexity of the tasks within the listed maintenance function varies at different maintenance levels, appropriate work time figures are to be shown for each level. The work time figure represents the average time required to restore an item (assembly, subassembly, component, module, end item, or system) to a serviceable condition under typical field operating conditions. This time includes preparation time (including any necessary disassembly/assembly time), troubleshooting/fault location time, and quality assurance time in addition to the time required to perform the specific tasks identified for the maintenance functions authorized in the MAC. The system designations for the various maintenance levels are as follows:

Field:

- C Operator or Crew maintenance
- O Unit maintenance
- F Direct Support maintenance

Sustainment:

- L Specialized Repair Activity
- H General Support maintenance
- D Depot maintenance

## NOTE

The "L" maintenance level is not included in column (4) of the MAC. Functions to this level of maintenance are identified by work time figure in the "H" column of column (4), and an associated reference code is used in the REMARKS column (6). This code is keyed to the remarks and the SRA complete repair application is explained there.

Column (5) Tools and Equipment Reference Code. Column (5) specifies, by code, those common tool sets (not individual tools), common Test, Measurement and Diagnostic Equipment (TMDE), and special tools, special TMDE and special support equipment required to perform the designated function. Codes are keyed to the entries in the tools and test equipment table.

Column (6) Remarks Code. When applicable, this column contains a letter code, in alphabetic order, which is keyed to the remarks table entries.

### **B-4. EXPLANATION OF COLUMNS IN THE TOOLS AND TEST EQUIPMENT REQUIREMENTS, SECTION III**

Column (1) - Tool or Test Equipment Reference Code. The tool or test equipment reference code correlates with a code used in column (5) of the MAC.

Column (2) - Maintenance Level. The lowest level of maintenance authorized to use the tool or test equipment.

Column (3) - Nomenclature. Name or identification of tool or test equipment.

Column (4) - National Stock Number (NSN). The NSN of the tool or test equipment.

Column (5) - Tool Number. The manufacturer's part number, model number, or type number.

### **B-5. EXPLANATION OF COLUMNS IN REMARKS, SECTION IV**

Column (1) - Remarks Code. The code recorded in Column (6) of the MAC.

Column (2) - Remarks. This column lists information pertinent to the maintenance function being performed as indicated in the MAC.

**SECTION II. MAINTENANCE ALLOCATION CHART  
FOR MODULAR FIELD KITCHEN (MFK).**

(1) GROUP NUMBER	(2) COMPONENT/ ASSEMBLY	(3) MAINTENANCE FUNCTION	(4) MAINTENANCE LEVEL					(5) TOOLS AND EQUIPMENT REFERENCE CODE	(6) REMARKS CODE
			FIELD		SUSTAINMENT				
			UNIT		DIRECT SUPPORT	GENERAL SUPPORT	DEPOT		
			C	O	F	H	D		
00	KITCHEN, MODULAR, FIELD								
01	TENT						5	A	
02	LANTERN, GASOLINE							B	
03	RACK ASSEMBLY, STORAGE	Inspect Service Repair	0.1 0.2	0.5	1.0		1	C D	
04	OVEN ASSEMBLY	Inspect Service Repair	0.1 0.2	0.8	1.0		1, 6	C D, F	
05	RACK, BURNER	Inspect Service Repair	0.1 0.1		1.0		1	C D	
06	RACK, BASE	Inspect Service Repair	0.1 0.1		1.0		1	C D	
07	GRIDDLE, ASSEMBLY								
0701	TOP, GRIDDLE	Inspect Service Repair	0.1 0.2	1.0			1	C D	
0702	RACK, BURNER, DOUBLE	Inspect Service Repair	0.1 0.1	0.8	1.0		1	C D, G	
0703	RACK, BASE, DOUBLE	Inspect Service Repair	0.1 0.1		1.0		1	C D	
08	STEAM TABLE ASSEMBLY								
0801	ADAPTER, TOP	Inspect Service Repair	0.1 0.1		1.0		1	C D	
0802	BODY, STEAM TABLE	Inspect Service Repair	0.1 0.1	0.8	1.0		1, 10, 12	C D	
0803	RACK, BURNER, DOUBLE	Inspect Service Repair	0.1 0.1	0.8	1.0		1	C D, G	
0804	RACK, BASE, DOUBLE	Inspect Service Repair	0.1 0.1		1.0		1	C D	
09	HEATER TANK ASSEMBLY	Inspect Service Repair	0.1 0.2	0.5	1.0		1, 6	C D, F	

**SECTION II. MAINTENANCE ALLOCATION CHART  
FOR MODULAR FIELD KITCHEN (MFK)—continued.**

(1) GROUP NUMBER	(2) COMPONENT/ ASSEMBLY	(3) MAINTENANCE FUNCTION	(4) MAINTENANCE LEVEL					(5) TOOLS AND EQUIPMENT REFERENCE CODE	(6) REMARKS CODE
			FIELD		SUSTAINMENT				
			UNIT		DIRECT SUPPORT	GENERAL SUPPORT	DEPOT		
			C	O	F	H	D		
10	COOKING POT CRADLE ASSEMBLY								
1001	CRADLE, COOKING POT	Inspect Service Repair	0.1 0.1			1.0		1, 6	C D, F
1002	RACK, BURNER	Inspect Service Repair	0.1 0.1			1.0		1	C D
1003	RACK, BASE	Inspect Service Repair	0.1 0.1			1.0		1	C D
11	BURNER UNIT, M2A							1, 2, 3, 4, 7, 8, 9, 11	E
12	OPENER, CAN, MOUNTED	Inspect Service Repair	0.1 0.1	0.2				1	C D
13	TABLE, FOLDING LEG	Inspect Service Repair	0.1 0.2	0.5		1.0		1	C D
14	DISPENSER, LIQUID	Inspect Service Repair	0.1 0.3	0.3				1	C
15	FOOD CONTAINER, INSULATED	Inspect Service Repair	0.1 0.3	0.5				1	C
16	STORAGE CABINET	Inspect Service Repair	0.1 0.2			1.0		1	C D
17	UTENSILS	Inspect Replace	0.1	0.1					H H
18	MISCELLANEOUS ASSEMBLIES BAG, DRINKING WATER STORAGE CAN, GASOLINE CAN, WATER								J  K K



**SECTION III. TOOL AND TEST EQUIPMENT  
FOR MODULAR FIELD KITCHEN (MFK).**

(1) TOOL OR TEST EQUIPMENT REFERENCE CODE	(2) MAINTENANCE LEVEL	(3) NOMENCLATURE	(4) NATIONAL STOCK NUMBER	(5) TOOL NUMBER
1	O	Tool Kit, General Mechanic's: Automotive	5180-00-177-7033	
2	C	Brush, Wire	7920-00-291-5815	
3	C	Cleaner, Burner Slot	5120-00-379-2490	
4	C	Pump, Inflating	4320-00-852-9036	
5	O	Repair Kit, Tentage	8340-00-262-5767	
6	F	Riveter, Blind, Hand	5120-00-017-2849	
7	C	Screwdriver, Cross Tip	5120-00-234-8913	
8	C	Screwdriver, Flat Tip	5120-00-222-8852	
9	C	Wrench, Adjustable	5120-00-240-5328	
10	O	Wrench, Adjustable	5120-00-449-8084	
11	C	Wrench Assembly (Combination)	5120-00-303-7737	
12	O	Wrench, Pipe	5120-00-277-1462	

**SECTION IV. REMARKS  
FOR MODULAR FIELD KITCHEN (MFK).**

(1) REMARKS CODE	(2) REMARKS
A	Refer to TM 10-8340-244-13 for Tent Maintenance Instructions.
B	Refer to FM 10-23 for Lantern Maintenance Instructions.
C	Service includes cleaning.
D	Weld and straighten at Direct Support Level.
E	Refer to TM 7360-204-13&P for Burner Maintenance Instructions.
F	Rivet at Direct Support Level.
G	Includes replacement of Heat Guards.
H	Inspect includes ensuring full compliment of utensils. Replace includes restocking missing items.
J	Refer to FM 10-23 and FM 21-10-1.
K	Refer to TM 10-7200-200-13.



## APPENDIX C

## COMPONENTS OF END ITEM AND BASIC ISSUE ITEMS LIST

## Section I. INTRODUCTION

**C-1 SCOPE.** This appendix lists Components of End Item (COEI) and Basic Issue Items (BII) for the MFK to help inventory items required for safe and efficient operation.

**C-2 GENERAL.** The Components of End Item List (COEI) is divided into the following sections:

a. Section II. Components of End Item. This listing is for informational purposes only, and is not authority to requisition replacements. These items are part of the end item, but are removed and separately packaged for transportation or shipment. As part of the end item, these items must be with the end item whenever it is issued or transferred between property accounts. Illustrations are furnished to assist you in identifying the items.

b. Section III. Basic Issue Items. These are the minimum essential items required to place the MFK in operation, to operate it, and to perform emergency repairs. Although shipped separately packed, BII must accompany the MFK during operation and whenever it is transferred between accountable officers. The accompanying illustrations will assist with hard-to-identify items. This manual is the authority to requisition replacement BII based on Modified Table of Organization and Equipment (MTOE) authorization of your MFK.

**C-3 EXPLANATION OF COLUMNS.** The following provides an explanation of columns found in the tabular listings:

a. Column (1) - Illustration Number (Illus Number). Indicates the illustration number of MFK components and accessories.

b. Column (2) - National Stock Number (NSN). Indicates the NSN assigned to the item and will be used for requisitioning purposes.

c. Column (3) - Description. CAGEC and Part Number. Indicates the Federal item name and, if required, a minimum description to identify and locate the item. The last line for each item indicates the CAGEC (in parenthesis) followed by the part number. If item needed differs for different models of this equipment, the model is shown under the "Usable On" heading in this column.

d. Column (4) - Unit of Measure (U/M). Indicates the measure used in performing the actual operational/maintenance function. This measure is expressed by a two-character alphabetical abbreviation (e.g., ea, in, pr).

e. Column (5) - Quantity Required (Qty Rqd). Indicates the quantity of the item authorized to be used with/on the equipment.

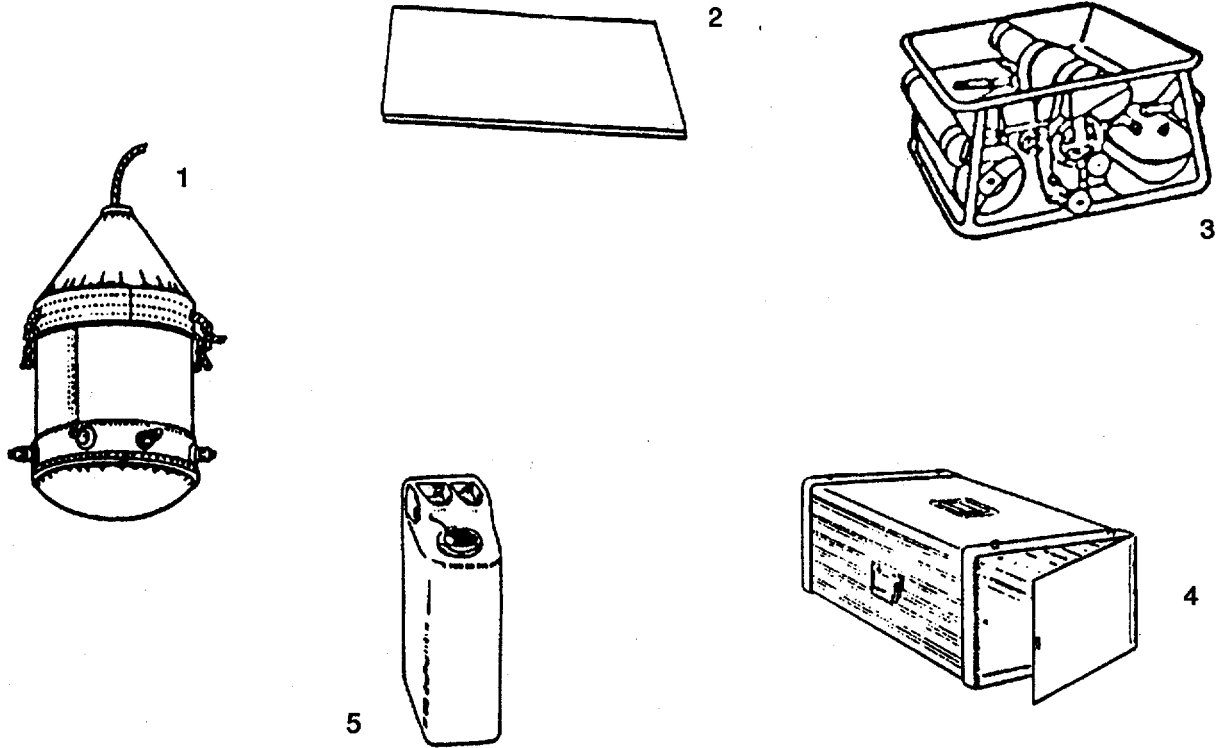

**Section II. COMPONENTS OF END ITEM**

(1) Illus Number	(2) National Stock Number	(3) Description, CAGEC, and Part Number	Usable on Code	(4) U/M	(5) Qty Rqr
1	4610-00-268-9890	Bag, water sterilization (81349) MIL-B-273		EA	1
2	7330-00-078-5706	Board, food, chopping (58536) A-A-391		EA	2
3	7310-01-113-9172	Burner Unit, gasoline (81349) MIL-B-40098		EA	6
4	7125-01-372-0102	Cabinet, Storage (81337) 5-13-4160		EA	2
5	7240-01-337-5269	Can. gasoline, military (81349) MIL-C-53109		EA	5

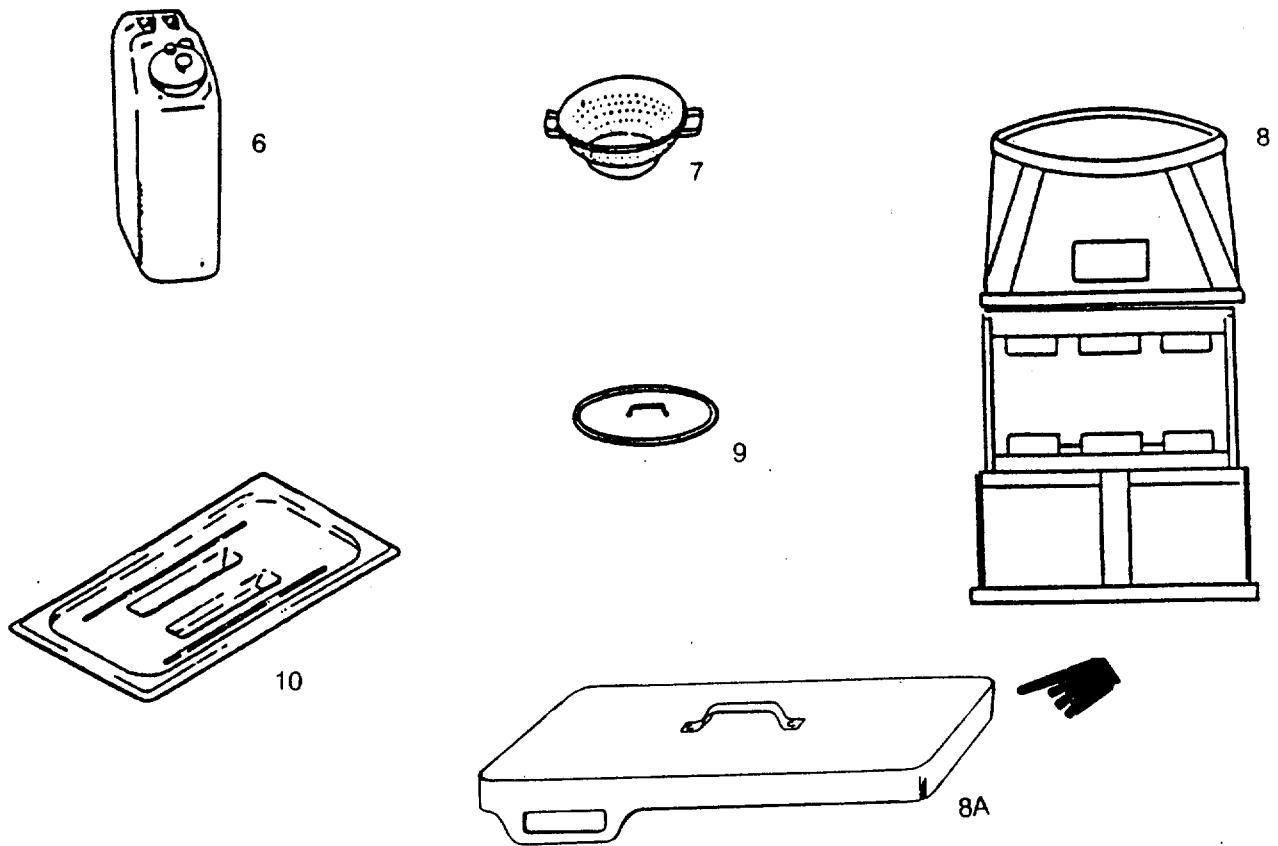

**Section II. COMPONENTS OF END ITEM**

(1) Illus Number	(2) National Stock Number	(3) Description, CAGEC, and Part Number	Usable on Code	(4) U/M	(5) Qty Rqr
6	7240-00-089-3827	Can, water, military (81349) MIL-C43613		EA	5
7	7330-00-266-7453	Colander, SS, 16-quart (80049) 6921793900		EA	1
8	7330-01-248-9964	Cooking Pot Cradle Assembly (81337) 5-13-3991		EA	2
8A	7330-00-263-8516	Cover, Baking & Roasting Pan (80244) MIL-P-17471 M2		EA	5
9	7330-00-250-6300	Cover, cooking pot (81349) MIL-P-1735		EA	4
10	7310-01-235-0922	Cover, pan, food serving (21669) MP-C-30-H		EA	36

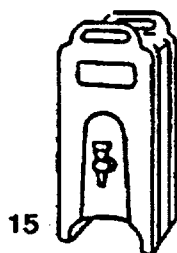
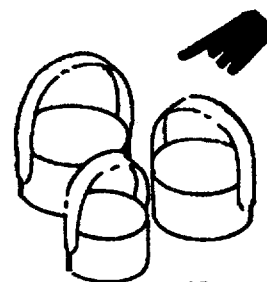
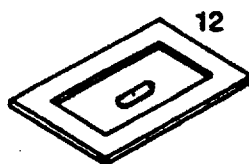
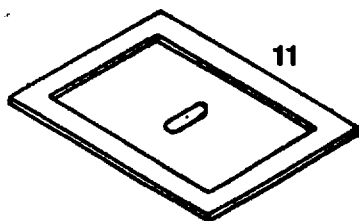

**Section II. COMPONENTS OF END ITEM**

(1) Illus Number	(2) National Stock Number	(3) Description, CAGEC, and Part Number	Usable on Code	(4) U/M	(5) Qty Rqr
11	7310-00-834-0480	Cover, steam table (56023) FC-120		EA	6
12	7310-01-107-1281	Cover, steam table (56023) FC-280		EA	6
13	7330-00-543-7097	Cutter Set, cookie (58536) A-A-50171		EA	1
14	7330-00-272-2489	Dipper, Kitchen (58536) A-A-1077		EA	2
15	7310-01-245-6937	Dispenser, liquid, insulated, 5-gallon (21669) 500LDC-G		EA	17

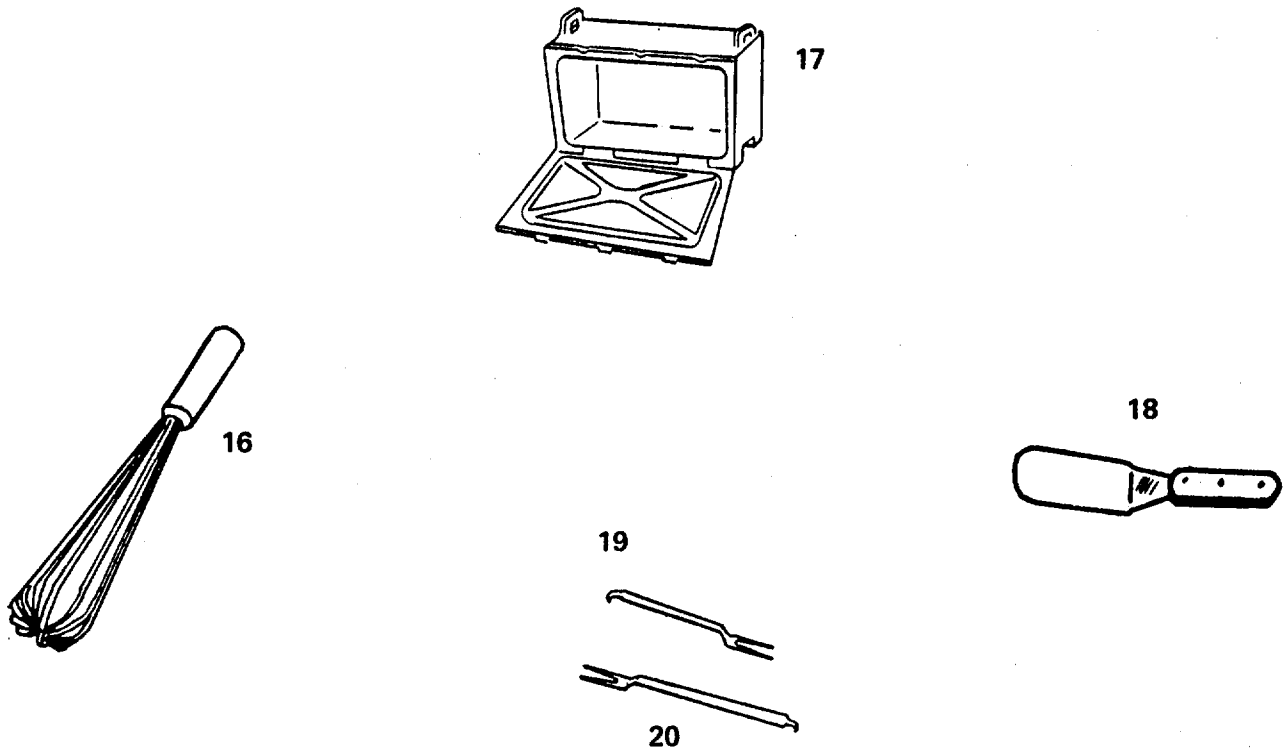

**Section II. COMPONENTS OF END ITEM**

(1) Illus Number	(2) National Stock Number	(3) Description, CAGEC, and Part Number	Usable on Code	(4) U/M	(5) Qty Rqr
16	7330-00-815-1458	Egg whip (58536) A-A-394		EA	1
17	7330-01-234-2163	Food container, insulated (21669) 200MPC1-G		EA	6
18	7330-00-256-2158	Food turner (80244) MIL-U-10815, TY4SZ2		EA	3
19	7340-00-223-7791	Fork, food preparation (80244) MIL-U-10815 TY1SZ1		EA	3
20	7340-00-223-7792	Fork, food preparation (80244) MIL-U-10815 TY1SZ2		EA	3

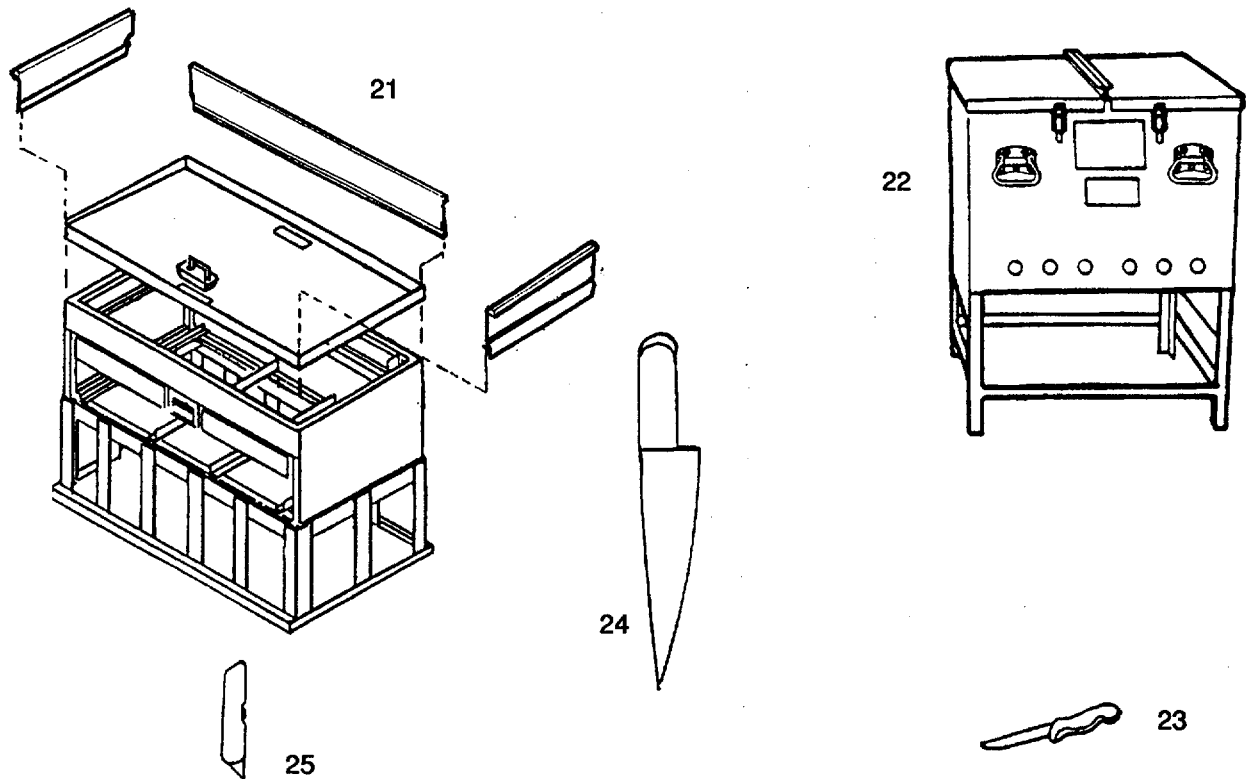

Section II. COMPONENTS OF END ITEM - CONT.

(1) Illus Number	(2) National Stock Number	(3) Description, CAGEC, and Part Number	Usable on Code	(4) U/M	(5) Qty Rqr
21	7310-01-388-6591	Griddle Assembly (81337) 5-13A210		EA	1
22	7360-01-248-6041	Heater Tank Assembly (81337) 5-13-3721		EA	1
23	7340-00-197-1271	Knife, boning (4Y739) 6447M		EA	2
24	7340-00-488-7950	Knife, cook's (80244) GGG-C-746 TY20GRD		EA	2
25	5110-00-892-5071	Knife, craftsman's (80244) GGG-K-494TY2		EA	2



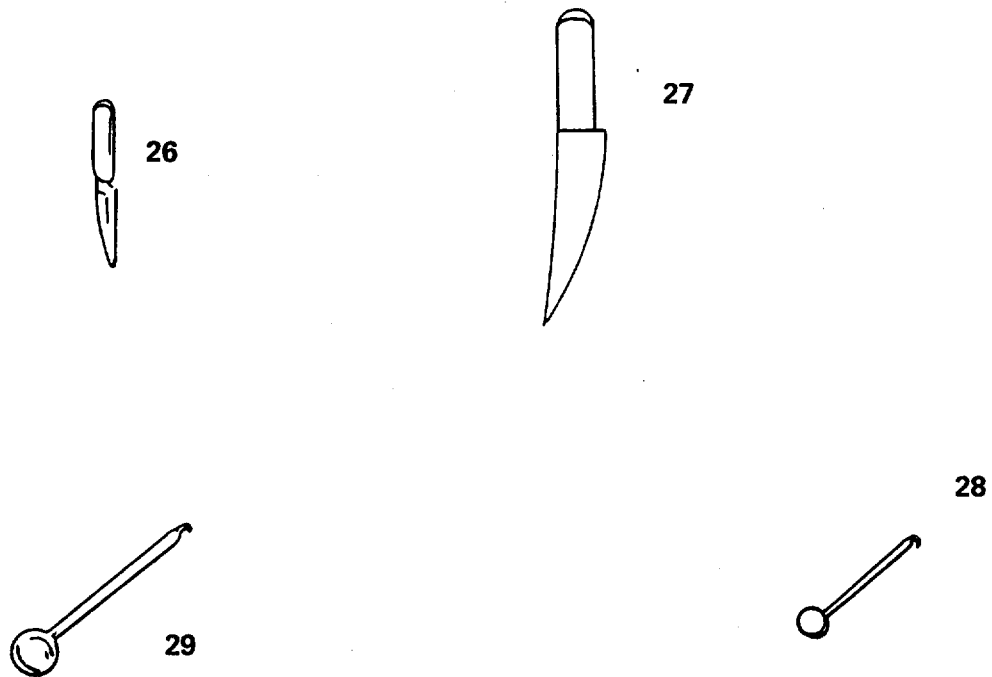

**Section II. COMPONENTS OF END ITEM - CONT.**

(1) Illus Number	(2) National Stock Number	(3) Description, CAGEC, and Part Number	Usable on Code	(4) U/M	(5) Qty Rqr
26	7340-00-488-7939	Knife, paring (80244) GGG-C-746 TY5GRD		EA	2
27	7340-00-406-6531	Knife, slicing (80244) GGG-C-746 TY6GRD		EA	2
28	7330-00-254-4793	Ladle, kitchen, 2 ounce (58536) A-A-1956		EA	2
28	7330-00-248-1153	Ladle, kitchen, 8 ounce (58536) A-A-1956		EA	2

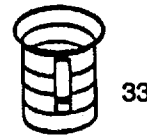
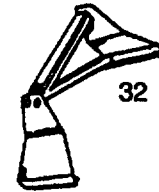
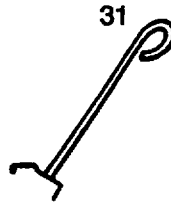

**Section II. COMPONENTS OF END ITEM**

(1) Illus Number	(2) National Stock Number	(3) Description, CAGEC, and Part Number	(4) U/M	(5) Qty Rqr
30	6260-00-837-0996	Lantern, gasoline (58536) A-A-52078	EA	2
31	7330-01-234-2164	Lifter, tray pack (81337) 5-13-3961	EA	2
32	7330-01-224-0914	Lifter, tray pack serving (81337) 5-13-3859	EA	2
33	7330-00-205-3096	Measure, liquid, 2 quart (58536) A-A-1751	EA	2
34	7330-00-272-4876	Measuring Set, spoon (58536) A-A-1954	EA	2

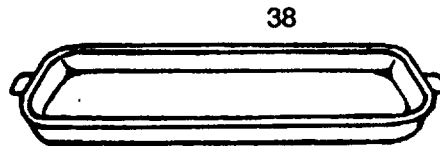
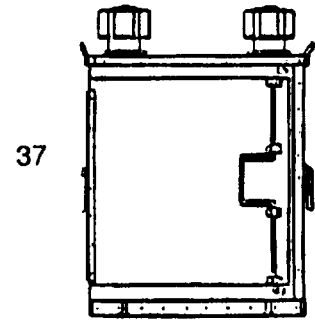
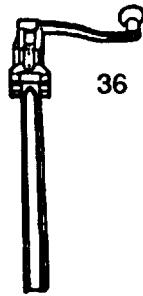

SECTION II. COMPONENTS OF END ITEM - CONT.

(1) ILLUS NUMBER	(2) NATIONAL STOCK NUMBER	(3) DESCRIPTION CAGEC AND PART NUMBER	USABLE ON CODE	(4) U/M	(5) QTY RQR
35	7330-01-245-0201	Opener, can, hand (81337) 5-13-3971		EA	2
36	7330-01-236-3155	Opener, can, mounted (81337) 5-13-3969		EA	2
37	7310-01-388-6606	Oven Assembly (81337) 5-13-4100		EA	2
38	7330-00-272-2589	Pan, baking and roasting (81349) MIL-P-12851		EA	10
39		Item 39 has been deleted			

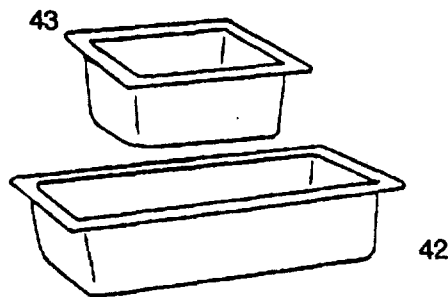
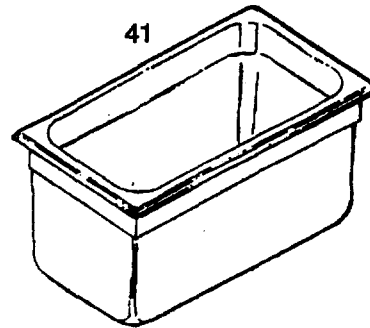
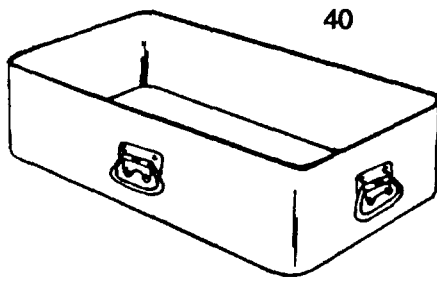

Section II. COMPONENTS OF END ITEM-CONT.

(1) ILLUS NUMBER	(2) NATIONAL STOCK NUMBER	(3) DESCRIPTION CAGEC AND PART NUMBER	USABLE ON CODE	(4) U/M	(5) QTY RQD
40	7330-00-485-7376	Pan, baking and roasting, (81349), MIL-P-1747		EA	5
41	7310-01-234-2189	Pan, food serving and storage (21669) MP36		EA	36
42	7310-00-238-5164	Pan, steam table (56023)124		EA	3
43	7310-00-576-4614	Pan, steam table (56023) 224		EA	6
44	7330-00-238-8316	Peeler, potato, hand (85812) W8079		EA	2

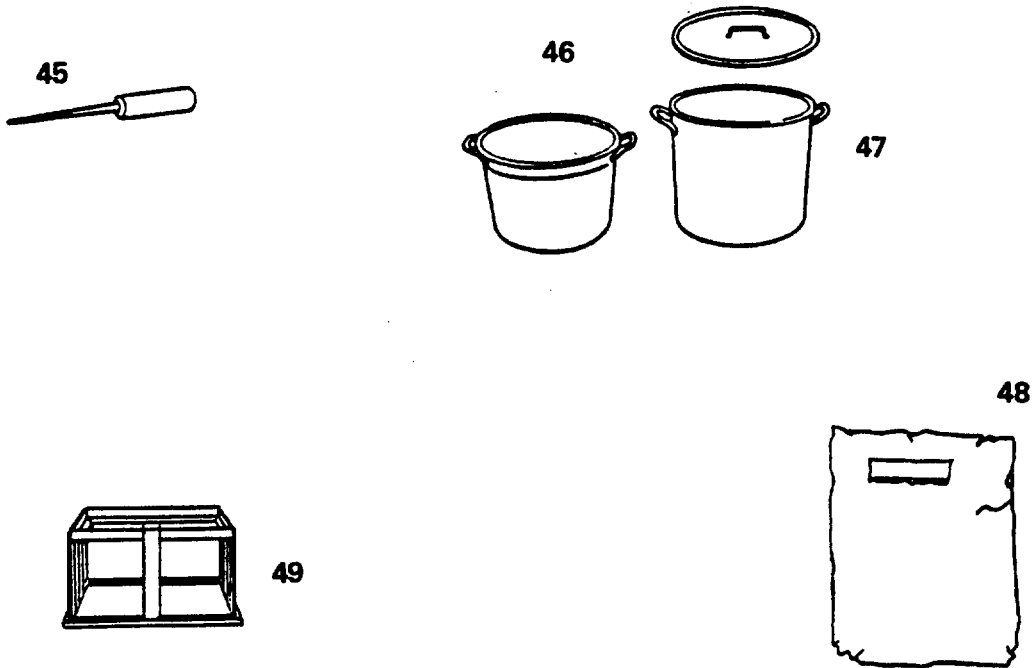

**SECTION II. COMPONENTS OF END ITEM - CONT.**

(1) Illus Number	(2) National Stock Number	(3) Description, CAGEC, and Part Number	Usable on Code	(4) U/M	(5) Qty Rqr
45	7330-00-257-4822	Pick, ice (58536) A-A-31		EA	1
46	7330-00-292-2306	Pot, cooking, w/o cover, 10-gallon (80244) MIL-P-1735 SZ1		EA	2
47	7330-00-292-2307	Pot, cooking, w/ cover, 15-gallon (80244) MIL-P-1735, SZ2		EA	2
48	7330-00-37-4439	Pot holder (97074) PANHANDLER		EA	4
49	7360-01-250-3652	Rack, base (81337) 5-13-3868		EA	2



50

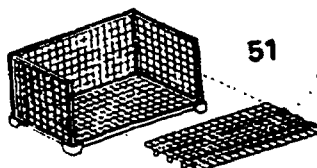

51



52



54

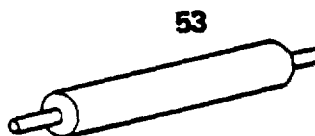

53

**SECTION II. COMPONENTS OF END ITEM - CONT.**

(1) Illus Number	(2) National Stock Number	(3) Description, CAGEC, and Part Number	(4) U/M	(5) Qty Rqr
50	7360-01-250-3649	Rack, burner (81337) 5-13-3875	EA	2
51	7125-01-334-3159	Rack Assembly, storage/drying (81337) 5-13-4050	EA	3
52	7360-00-274-7088	Roll, cutlery (81349) MIL-R-1982	EA	1
53	7330-00-153-9749	Rolling pin (58536) A-A-2368	EA	1
54	7330-00-205-1950	Scraper, baker's (81349) MIL-S-17531	EA	1

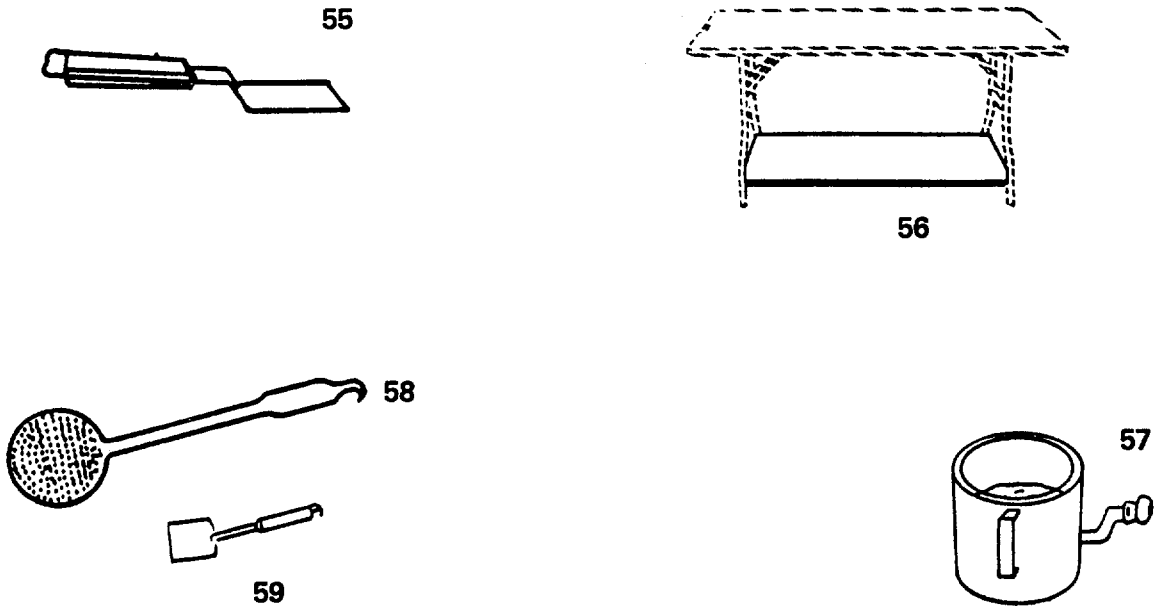

**SECTION II. COMPONENTS OF END ITEM - CONT.**

(1) Illus Number	(2) National Stock Number	(3) Description, CAGEC, and Part Number	Usable on Code	(4) U/M	(5) Qty Rqr
55	7340-00-272-9586	Server, pie and cake (80244) GGG-C-746, TY21 GRD		EA	1
56	5340-01-333-8486	Shelf (81337) 5-13-4257		EA	2
57	7330-00-184-0089	Sifter, flour, hand (58536) A-A-467		EA	1
58	7330-00-680-2635	Skimmer, kitchen (58536) A-A-1072		EA	2
59	7330-00-849-5194	Spatula (19099) NO REF		EA	2

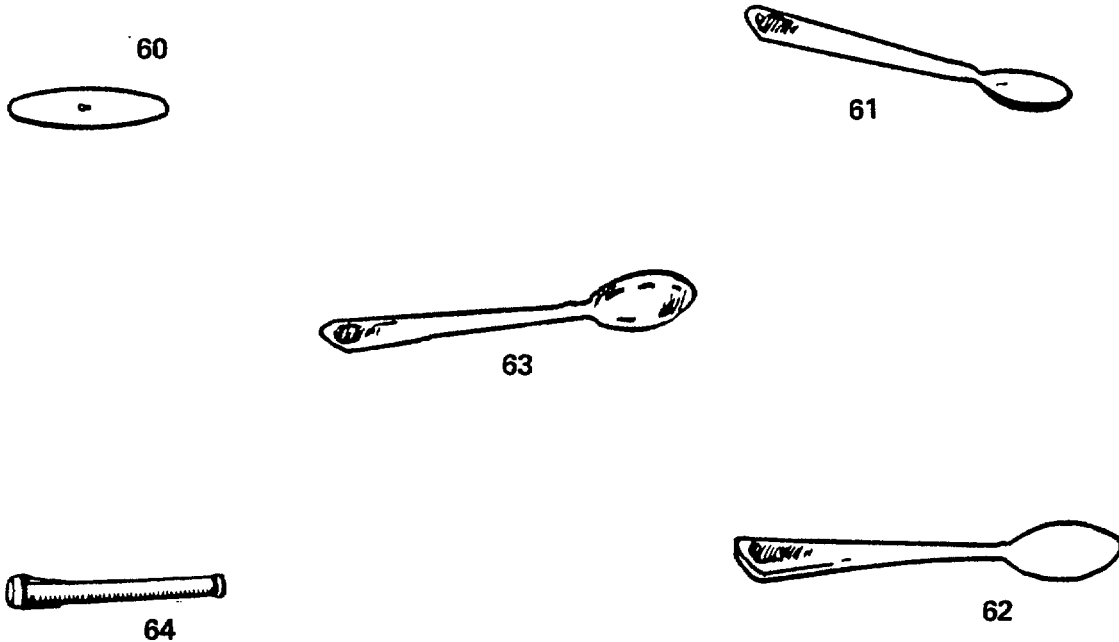

**SECTION II. COMPONENTS OF END ITEM - CONT.**

(1) Illus Number	(2) National Stock Number	(3) Description, CAGEC, and Part Number	Usable on Code	(4) U/M	(5) Qty Rqr
60	7330-00-379-2544	Splash plate (81349) 2-9-120PT224		EA	2
61	7340-00-240-7080	Spoon, food service, basting, 15-inch (58536) A-A-1082		EA	4
62	7340-00-223-7800	Spoon, food service, basting, 21-inch (80244) MIL-U-10815 TY2SZ2		EA	4
63	7340-00-205-1421	Spoon, service, slotted, 15-inch (58536) A-A-1082		EA	8
64	7240-00-177-6154	Spout, can, flexible (09647) 838A7511		EA	1



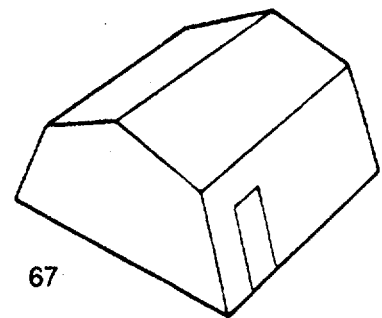
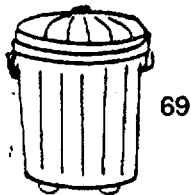
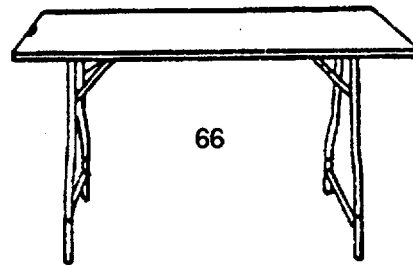
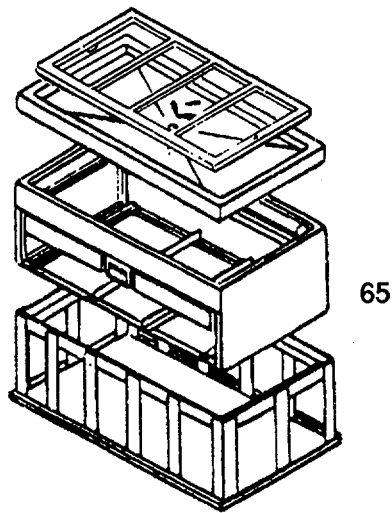

SECTION II. COMPONENTS OF END ITEM - CONT.

(1) Illus Number	(2) National Stock Number	(3) Description, CAGEC, and Part Number	Usable on Code	(4) U/M	(5) Qty Rqr
65	7310-01-388-6578	Steam Table Assembly (81337) 5-134212		EA	1
66	7105-01-333-8493	Table, Folding Leg (81337)134242		EA	2
67	8340-01-185-2613	Tent, extendible, modular 16 by 20 foot Utility (81349) MIL-T44271		EA	1
68	7330-00-616-0997	Tongs, food serving, ss, 12-inch (64067)7330-00616-0997		EA	3
69	7240-00-151-6629	Waste Receptacle (58536)A-A-295		EA	2

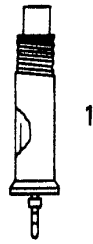

**SECTION II. COMPONENTS OF END ITEM - CONT.**

(1) Illus Number	(2) National Stock Number	(3) Description, CAGEC, and Part Number	(4) U/M	(5) Qty Rqr
1	7310-00-999-2552	<p style="text-align: center;"><u>ON BOARD SPARES</u></p> Preheater generator (81337) 5-11-1232 PIECE 5-10	EA	6

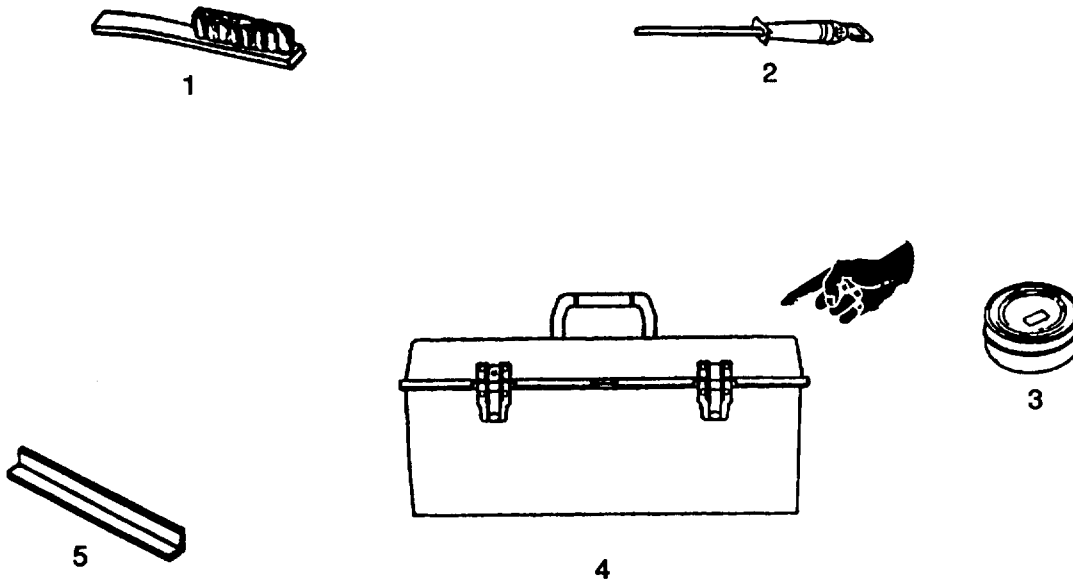

Section III. BASIC ISSUE ITEMS

(1) ILLUS NUMBER	(2) NATIONAL STOCK NUMBER	(3) DESCRIPTION CAGEC AND PART NUMBER	(4) USABLE ON CODE U/M	(5) QTY RQD
1	7920-00-291-5815	Brush, wire, scratch (83421) 7920-00-291-5815	EA	1
2	7330-00-550-7592	Butcher's steel (80244) GGG-C-746 TY12GRC	EA	1
3	8110-01-390-7839	Can, slip cover top (2A394) S10S	EA	1
4	7310-01-411-2271	Chest, tool, gasoline (59562) G7220	EA	1
5	5120-00-379-2490	Cleaner, burner, slot 81349) MIL-C-1429	EA	1

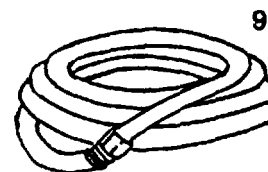
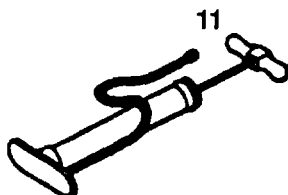
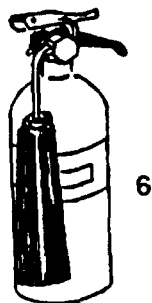

Section III. BASIC ISSUE ITEMS-Cont.

(1) ILLUS NUMBER	(2) NATIONAL STOCK NUMBER	(3) DESCRIPTION CAGEC AND PART NUMBER	USABLE ON CODE	(4) U/M	(5) QTY RQD
6	4210-01-149-1356	Extinguisher, fire (19207)12255633-1		EA	3
7	6545-00-919-6650	First aid kit, general purpose (81923) 9-196650		EA	1
8	5120-00-692-5485	Hammer, hand, 16 ounce (58536) A-A-1307		EA	1
9	4720-00-729-5334	Hose assembly, nonmetallic (81348) L-H-750TY2GRA		EA	1
10	5120-00-223-7397	Pliers, slip joint (56161) 10510983		EA	1
11	4320-00-652-9036	Pump, inflating, manual (89346) 52161 R91		EA	1

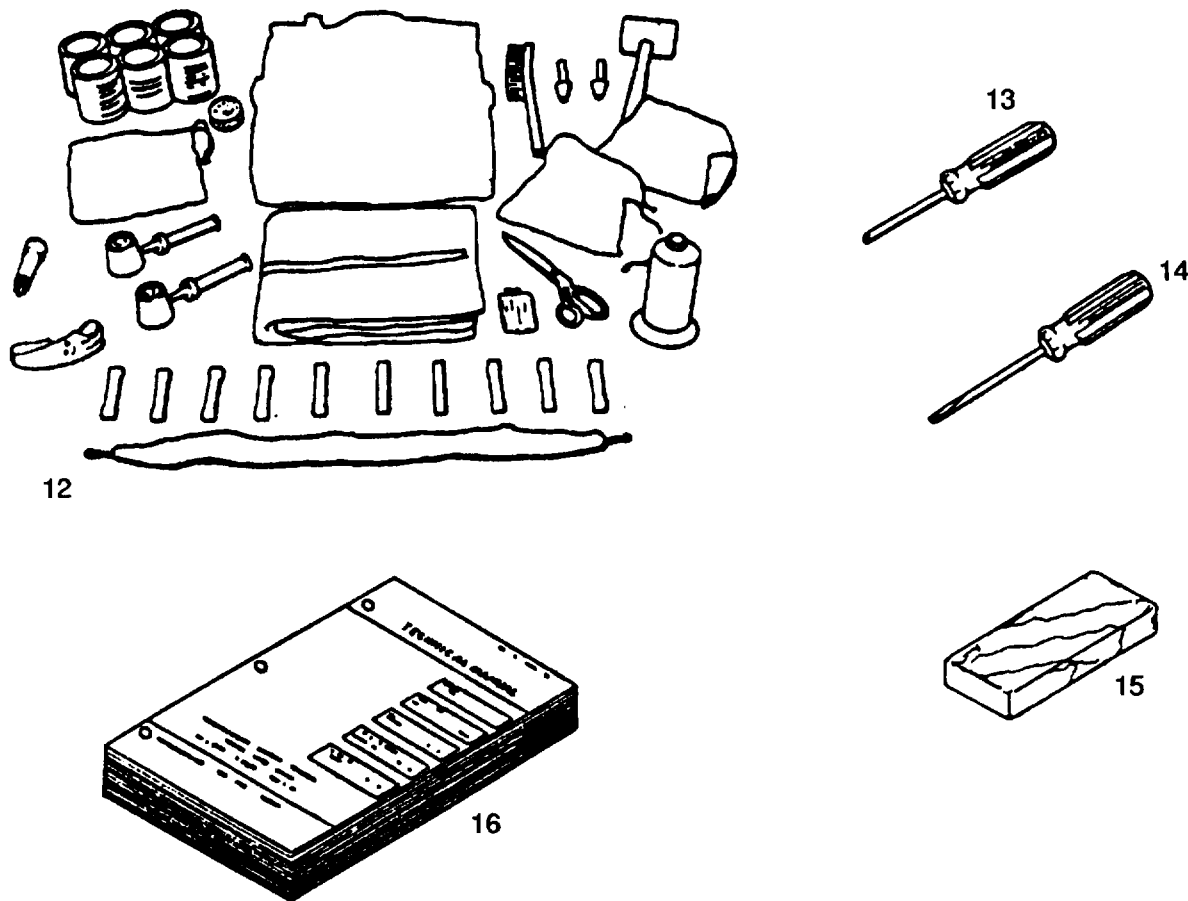

Section III. BASIC ISSUE ITEMS- Cont.

(1) ILLUS NUMBER	(2) NATIONAL STOCK NUMBER	(3) DESCRIPTION CAGEC AND PART NUMBER	USABLE ON CODE	(4) U/M	(5) QTY RQD
12	8340-00-262-5767	Repair kit, tentage (81349) MIL-C-3372		EA	1
13	5120-00-234-8913	Screwdriver, cross tip, 4 inches exposed length of blade, No. 2 blade point (19207) 11655777-12		EA	1
14	5120-00-222-8852	Screwdriver, flat tip, 4 inches exposed length of blade, (77948) 225498		EA	1
15	5345-00-198-8040	Stone, sharpening (70752) C69M		EA	1
16		Technical Manual TM 10-7360-204-13&P		EA	1

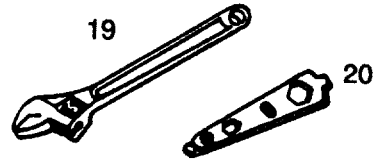
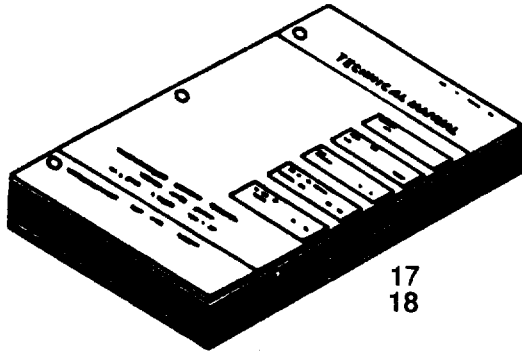

Section III. BASIC ISSUE ITEMS- Cont.

(1) ILLUS NUMBER	(2) NATIONAL STOCK NUMBER	(3) DESCRIPTION CAGEC AND PART NUMBER	(4) USABLE ON CODE U/M	(5) QTY RQD
17		Technical Manual TM 10-7360-208-13&P	EA	1
18		Technical Manual TM 10-8340-224-13	EA	1
19	5120-00-240-5328	Wrench, adjustable (39428) 5385A13	EA	1
20	5120-00-303-7737	Wrench assembly (combination) (80309) 520-950	EA	1

APPENDIX D

ADDITIONAL AUTHORIZATION UST

Section I. INTRODUCTION

**D-1 SCOPE.** This appendix lists additional items authorized for the support of the MFK.

**D-2 GENERAL.** This list identifies items that do not have to accompany the MFK and that do not have to be turned in with it. These items are all authorized to you by CTA, MTOE, TDA, or JTA.

**D-3 EXPLANATION OF USTING.** National Stock Numbers, descriptions, and quantities are provided to help you identify and request the additional items you require to support this equipment. The items are listed in alphabetical sequence by item name under the type document (i.e., CTA, MTOE, TDA, or JTA) which authorizes the item(s) to you. If the item you require differs between serial numbers of the same model, effective serial numbers are shown in the last line of the description. If item required differs for different models of this equipment, the model is shown under the 'Usable on' heading in the description column.

SECTION II. ADDITIONAL AUTHORIZATION UST

(1) NATIONAL STOCK NUMBER	(2) DESCRIPTION QTY		(3)	(4)
	CAGEC & PART NUMBER	USABLE ON CODE	U/M	AUTH
	<u>CTA AUTHORIZED ITEMS</u>			
8415-00-634-5023	APRON, UTILITY (81348) ZZA605		EA	6
8340-01-186-3025	FLOOR, TENT (81349) MIL-T-44243		EA	2
	GLOVE, NITRILE (30716) A1810		PR	8
4520-00-927-4214	HEATER, SPACE (81349) MIL-H-13514		EA	1
8340-01-211-9638,	LNER, TENT (81349) MIL-T-44222		EA	2





## Appendix E

## EXPENDABLE/DURABLE SUPPLIES AND MATERIALS LIST

## Section I. INTRODUCTION

**E-1. SCOPE.** This appendix lists expendable supplies and materials you will need to operate and maintain the MFK. This listing is for informational purposes only and is not authority to requisition the listed items. These items are authorized to you by CTA 50-970, Expendable/Durable Items (except Medical Class 5, Repair Parts, and Heraldic items), or CTA 8-100, Army Medical Department Expendable/Durable Items.

**E-2. EXPLANATION OF COLUMNS.**

a. Column (1) - Item Number. This number is assigned to the entry in the listing and is referenced in the narrative instructions to identify the material (e.g., use cleaning compound, item 5, Appendix E).

b. Column (2) - Level. This column identifies the lowest level of maintenance that requires the listed item.

C - Operator/Crew

c. Column (3) - National Stock Number. This is the NSN assigned to the item; use it to request or requisition the item.

d. Column (4) - Description. Identifies the Federal item name and, if required, a description to identify the item. The last line for each item indicates the Commercial and Government Entity Code (CAGEC) in parenthesis, followed by the part number.

e. Column (5) - Unit of Measure U/M. Indicates the measure used in performing the actual maintenance function. This measure is expressed by a two-character alphabetical abbreviation (e.g., ea, in, pr). If the unit of measure differs from the unit of issue, requisition the lowest unit of issue that will satisfy your requirements.

## Section II. EXPENDABLE/DURABLE SUPPLIES AND MATERIALS LIST

(1) Item Number	(2) Level	(3) National Stock Number	(4) Description	(5) U/M
1	O	8040-01-372-5071	ADHESIVE (ORC50) 77E	OZ
2	C	8030-00-087-6630	ANTISEIZE THREAD COMPOUND (81349) MIL-T-83483	OZ
3	C	8135-00-226-3124	BARRIER MATERIAL (81349) MIL-B-121	RO
4	C	6850-00-664-5685	DRY CLEANING SOLVENT (58536) A-A-711 TY1	GL
5	C	9150-00-273-2389	LUBRICATING OIL, GENERAL PURPOSE (81348) W-L-800	OZ
6	C	7920-00-659-9175	PAD, SCOURING (80244) L-P-0050 TY1SZ1	EA
7	O	8030-00-201-0996	SEALING COMPOUND (81348) TT-S-1732	OZ

**Appendix F. UNIT AND DIRECT SUPPORT  
MAINTENANCE REPAIR PARTS AND SPECIAL TOOLS LIST**

**Section I. INTRODUCTION**

**F-1 SCOPE.** This RPSTL lists and authorizes spares and repair parts; special tools; special test, measurement, and diagnostic equipment (TMDE); and other special support equipment required for performance of unit and direct support maintenance of the Modular Field Kitchen. It authorizes the requisitioning, issue, and disposition of spares, repair parts and special tools as indicated by the source, maintenance and recoverability (SMR) codes.

**F-2 GENERAL.** In addition to this section, Introduction, this Repair Parts and Special Tools List is divided into the following sections:

**a. Section II. Repair Parts List.** A list of spares and repair parts authorized by this RPSTL for use in the performance of maintenance. This list also includes parts which must be removed for replacement of the authorized parts. Parts lists are composed of functional groups in ascending alphanumeric sequence, with the parts in each group listed in ascending figure and item number sequence. Bulk materials are listed in item name sequence. Repair parts kits are listed separately in their own functional group within Section II. Repair parts for repairable special tools are also listed in this section. Items are shown in the associated illustration(s)/figure(s).

**b. Section II. Special Tools List.** A list of special tools, special TMDE, and other special support equipment authorized by this RPSTL (as indicated by Basis of Issue (BOI) information in DESCRIPTION AND USABLE ON CODE column) for the performance of maintenance.

**c. Section IV. Cross--references Indexes.** A list, in National Item Identification Number (NIIN) sequence, of all National stock numbered items appearing in the listing, followed by a list in alphanumeric sequence of all part numbers appearing in the listings. National stock numbers and part numbers are cross referenced to each illustration figure and item number appearance. The figure and item number index lists figure and item number in alphanumeric sequence and cross references NSN, CAGEC and part number.

**F-3 EXPLANATION OF COLUMNS (SECTIONS II AND 111).**

**a. ITEM NO. (Column (1)).** Indicates the number used to identify items called out in the illustration.

**b. SMR Code (Column (2)).** The Source, Maintenance, and Recoverability (SMR) code is a 5-position code containing supply/requisitioning information, maintenance category authorization criteria, and disposition instruction, as shown in the following breakout:

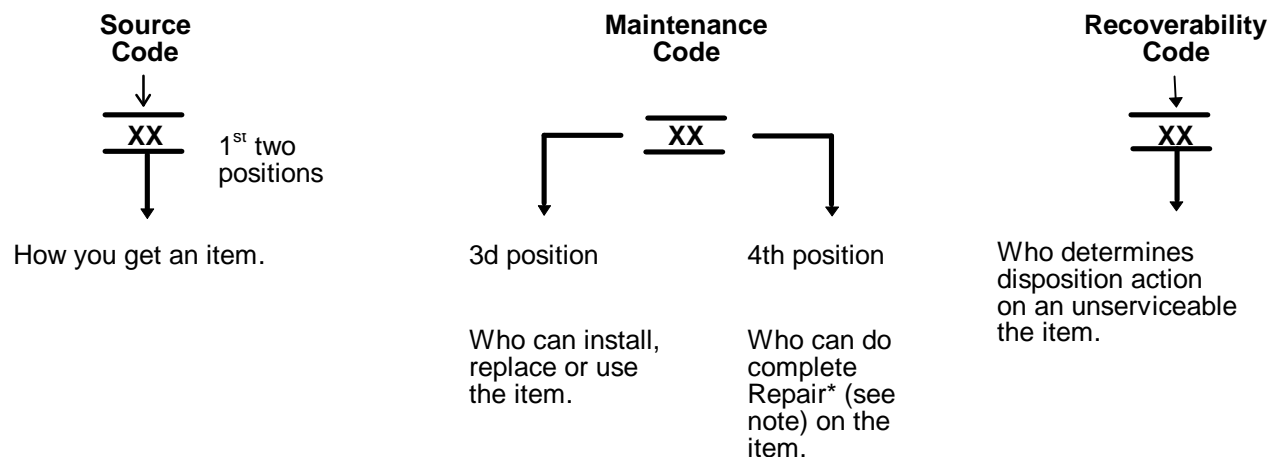

\*Complete Repair: Maintenance capacity, capability, and authority to perform all corrective maintenance tasks of the "Repair" function in a use/user environment in order to restore serviceability to a failed item.

(1) Source Code. The source code tells you how to get an item needed for maintenance, repair, or overhaul of an end item/equipment. Explanations of source codes follows:

Code	Explanation
PA PB PC** PD PE PF PG	<p>Stocked items; use the applicable NSN to requested requisition items with these source codes. They are authorized to the category indicated by the code entered in the 3rd position of the SMR code.</p> <p>NOTE: Items coded PC are subject to deterioration.</p>
KD KF KB	<p>Items with these codes are not to be requested/requisitioned individually. They are part of a kit which is authorized to the maintenance category indicated in the 3rd position of the SMR code. The complete kit must be requisitioned and applied.</p>
MO - (Made at org/AVUM Level) MP - (Made at DS/AVUM Level) MH - (Made at GS Level) ML - (Made at Specialized Repair Activity (SRA)) MD - (Made at Depot)	<p>Items with these codes are not to be requested/requisitioned individually. They must be made from bulk material which is identified by the part number in the DESCRIPTION and USABLE ON CODE (UOC) column and listed in the Bulk Material group of the repair parts list in this RPSTL. If the item is authorized to you by the 3rd position code of the SMR code, but the source code indicates it is made at a higher level, order the item from the higher level of maintenance.</p>
AO - (Assembled by org/AVUM Level) AF - (Assembled by DS/AVIM Level) AH - (Assembled by GS Category) AL - (Assembled by SRA) AD - (Assembled by Depot)	<p>Items with these codes are not to be requested/requisitioned individually. The parts that make up the assembled item must be requisitioned or fabricated and assembled at the level of maintenance indicated by the source code. If the 3rd position code of the SMR code authorizes you to replace the item, but the source code indicates the items are assembled at a higher level, order the item from the higher level of maintenance.</p>
XA -	Do not requisition "XA"-coded item. Order its next higher assembly. (Also, refer to the NOTE below.)
XB -	If an "XB" item is not available from salvage, order it using the CAGEC and part number given.
XC -	Installation drawing, diagram, instruction sheet, field service drawing, that is identified by Reciprocating Compressor manufacturer's part number.
XD -	Item is not stocked. Order an "XD"-coded item through normal supply channels using the CAGEC and part number given if no NSN is available.

**NOTE**

Cannibalization or controlled exchange, when authorized, may be used as a source of supply for items with the above source codes, except for those source coded "XA" or those aircraft support items restricted by requirements of AR 750-1.

**(2) Maintenance Code.** Maintenance codes tells you the level(s) of maintenance authorized to USE and REPAIR support items. The maintenance codes are entered in the third and fourth positions of the SMR code as follows:

**(a).** The maintenance code entered in the third position tells you the lowest maintenance level authorized to remove, replace, and use an item. The maintenance code entered in the third position will indicate authorization to one of the following levels of maintenance.

<b>Code</b>	<b>Application/Explanation</b>
C -	Crew or operator maintenance done with unit or aviation unit maintenance.
O -	Unit or aviation unit category can remove, replace, and use the item.
F -	Direct support or aviation intermediate level can remove, replace, and use the item.
H -	General support level can remove, replace, and use the item.
L -	Specialized repair activity can remove, replace, and use the item.
D -	Depot level can remove, replace, and use the item.

**(b).** The maintenance code entered in the fourth position tells whether or not the item is to be repaired and identifies the lowest maintenance level with the capability to do complete repair (i.e., perform all authorized repair functions.) NOTE: Some limited repair may be done on the item at a lower level of maintenance, if authorized by the Maintenance Allocation Chart (MAC) and SMR codes. This position will contain one of the following maintenance codes.

<b>Code</b>	<b>Application/Explanation</b>
O -	Unit or (aviation unit) is the lowest level that can do complete repair of the item.
F -	Direct support or aviation intermediate is the lowest level that can do complete repair of the item.
H -	General Support is the lowest level that can do complete repair of the item.
L -	Specialized repair activity is the lowest level that can do complete repair of the item.
D -	Depot is the lowest level that can do complete repair of the item.
Z -	Nonrepairable. No repair is authorized.
B -	No repair is authorized. (No parts or special tools are authorized for the maintenance of a "B" coded Item). However, the item may be reconditioned by adjusting, lubricating, etc., at the user level.

**(3) Recoverability Code.** Recoverability codes are assigned to items to indicate the disposition action on unserviceable items. The recoverability code is entered in the fifth position of the SMR Code as follows:

**Recoverability  
Codes**

**Application/Explanation**

- Z - Nonrepairable item. When unserviceable, condemn and dispose of the item at the level of maintenance shown in 3d position of SMR Code.
- O - Repairable item. When not economically repairable, condemn and dispose of the item unit or aviation unit level
- F - Repairable item. When uneconomically repairable, condemn and dispose of the item at the direct support or aviation intermediate level
- H - Repairable item. When uneconomically repairable, condemn and dispose of the item at the general support level.
- D - Repairable item. When beyond lower level repair capability, return to depot. Condemnation and disposal of item not authorized below depot level.
- L - Repairable item. Condemnation and disposal not authorized below specialized repair activity (SRA).
- A- Item requires special handling or condemnation procedures because of specific reasons (e.g., precious metal content, high dollar value, critical material, or hazardous material). Refer to appropriate manuals/directives for specific instructions.

**c. CAGEC (Column (3)).** The Commercial and Government Entity Code (CAGEC) is a 5digit numeric code which is used to identify the manufacturer, distributor, or Government agency, etc., that supplies the item.

**d. PART NUMBER (Column (4)).** Indicates the primary number used by the manufacturer, (individual, company, firm, corporation, or Government activity), which controls the design and characteristics of the item by means of its engineering drawings, specifications standards, and inspection requirements to identify an item or range of items.

**NOTE**

When you use an NSN to requisition an item, the item you receive may have a different part number from the part ordered.

**e. DESCRIPTION AND USABLE ON CODE (UOC) (Column (5)).** This column includes the following information:

- (1) The Federal item name and, when required, a minimum description to identify the item.
- (2) The physical security classification of the item is indicated by the parenthetical entry, e.g., PhySec C1 - Confidential, PhySec C1 (S) - Secret, PhySec C1 (T) -Top Secret.
- (3) Items that are included in kits and sets are listed below the name of the kit or set.
- (4) Spare/repair parts that make up an assembled item are listed immediately following the assembled item line entry.
- (5) Part numbers for bulk materials are referenced in this column in the line item entry for the item to be manufactured/fabricated.
- (6) When the item is not used with all serial numbers of the same model, the effective serial numbers are shown on the last line(s) of the description (before UOC).

(7) The usable on code, when applicable (see paragraph 5, Special Information).

(8) In the Special Tools List section, the basis of issue (BOI) appears as the last line(s) in the entry for each special tool, special TMDE, and other special support equipment. When density of equipments supported exceeds density spread indicated in the basis of issue, the total authorization is increased proportionately.

(9) The statement "END OF FIGURE" appears just below the last item description in Column 5 for a given figure in both Section II and Section III.

(10) The indenture, shown as dots appearing before the repair part, indicates that the item is a repair part of the next higher assembly.

**f. QTY (Column (6)).** The QTY (quantity per figure column) indicates the quantity of the item used in the breakout shown on the illustration figure, which is prepared for a functional group, subfunctional group, or an assembly. "AV" appearing in this column in lieu of a quantity indicates that the quantity is variable and may vary from application to application.

**F-4 EXPLANATION OF COLUMNS (SECTION IV).**

**a. NATIONAL STOCK NUMBER (NSN) INDEX**

**(1) STOCK NUMBER column.** This column lists the NSN by National item identification number (NIIN) sequence. The NIIN consists of the last nine digits of the NSN, i.e.

NSN
<hr style="width: 100%; border: 0.5px solid black;"/>
5305-01-574-1 467
NIIN

When using this column to locate an item, ignore the first 4 digits of the NSN. However, the complete NSN should be used when ordering items by stock number.

**(2) FIG. column.** This column lists the number of the figure where the item is identified/located. The figures are in numerical order in Section II and Section III.

**(3) ITEM column.** The item number identifies the item associated with the figure listed in the adjacent FIG. column. This item is also identified by the NSN listed on the same line.

**b. PART NUMBER INDEX.** Part numbers in this index are listed by part number in ascending alphanumeric sequence (i.e., vertical arrangement of letter and number combination which places the first letter or digit of each group in order A through Z, followed by the numbers 0 through 9 and each following letter or digit in like order).

**(1) CAGEC column.** The Commercial and Government Entity Code (CAGEC) is a 5-digit numeric code used to identify the manufacturer, distributor, or Government agency, etc., that supplies the item.

**(2) PART NUMBER column.** Indicates the primary number used by the manufacturer (individual, firm, corporation, or Government activity), which controls the design and characteristics of the item by means of its engineering drawings, specifications standards, and inspection requirements to identify an item or range of items.

**(3) STOCK NUMBER column.** This column lists the NSN for the associated part number and manufacturer identified in the PART NUMBER and CAGEC columns to the left.

**(4) FIG. column.** This column lists the number of the figure where the item is identified/located in Sections II and III.

**(5) ITEM column.** The item number is that number assigned to the item as it appears in the figure referenced in adjacent figure number column.

**c. FIGURE AND ITEM NUMBER INDEX**

**(1) FIG. column.** This column lists the number of the figure where the item is identified/located in Section II and III.

**(2) ITEM column.** The item number is that number assigned to the item as it appears in the figure referenced in the adjacent figure number column.

**(3) STOCK NUMBER column.** This column lists the NSN for the item.

**(4) CAGEC column.** The Commercial and Government Entity Code (CAGEC) is a 5digit numeric code used to identify the manufacturer, distributor, or Government agency, etc., that supplies the item.

**(5) PART NUMBER column.** Indicates the primary number used by the manufacturer (individual, firm, corporation, or Government activity), which controls the design and characteristics of the item by means of its engineering drawings, specifications standards, and inspection requirements to identify an item or range of items.

**F-5 SPECIAL INFORMATION.**

**a. USABLE ON CODE.** The usable on code appears in the lower corner of the Description column heading. Usable on codes are shown as "UOC" in the Description Column justified left) on the last line applicable item description nomenclature. Uncoded items are applicable to all models.

**b. ASSOCIATED PUBUCATIONS.** The publications listed below pertains to the Modular Field Kitchen and its components.

Publication	Short Title
Not Applicable	

**F-6 HOW TO LOCATE REPAIR PARTS.**

**a. When National Stock Number or Part Number is NOT Known.**

**(1) First.** Using the table of contents, determine the assembly group or subassembly group to which the item belongs. This is necessary since figures are prepared for assembly groups and subassembly groups, and listings are divided into the same groups.

**(2) Second.** Find the figure covering the assembly group or subassembly group to which the item belongs.

**(3) Third.** Identify the item on the figure and note the item number.

**(4) Fourth.** Refer to the Repair Parts List for the figure to find the part number for the item number noted on the figure.

**(5) Fifth.** Refer to the Part Number Index to find the NSN, if assigned.



**b. When National Stock Number or Part Number Is Known.**

**(1) First.** Using the Index of National Stock Numbers and Part Numbers, find the pertinent National Stock Number or Part Number. The NSN index is in National Item Identification Number (NIIN) sequence (see c-4a.(1)). The part numbers in the Part Number index are listed in ascending alphanumeric sequence (see paragraph c-4.b). Both indexes cross-reference you to the illustration figure and item number of the item you are looking for.

**(2) Second.** After finding the figure and item number, verify that the item is the one you are looking for, then locate the item number in the repair parts list for the figure.

**F-7. ABBREVIATIONS.** Abbreviations used in this manual are listed in MIL-STD-1 2.

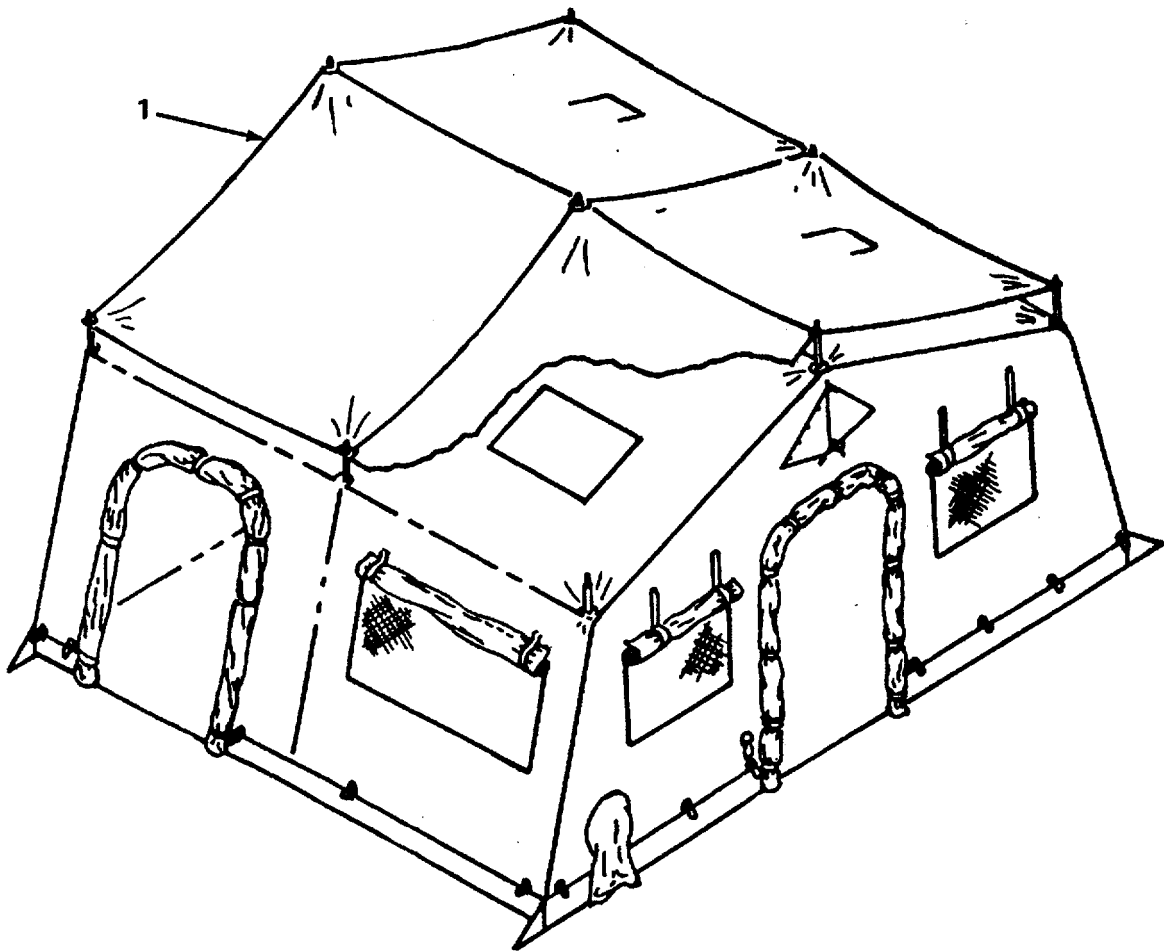

Figure F-1. Tent

SECTION II		TM10-7360-208-13&P C01			
(1)	(2)	(3)	(4)	(5)	(6)
ITEM NO	SMR CODE	CAGEC	PART NUMBER	DESCRIPTION AND USABLE ON CODES (UOG)	QTY
				GROUP 01 TENT	
				FIG. F-1 TENT	
*	1	PAOFF	81349 MIL-T-44271	TENT.....	1

END OF FIGURE

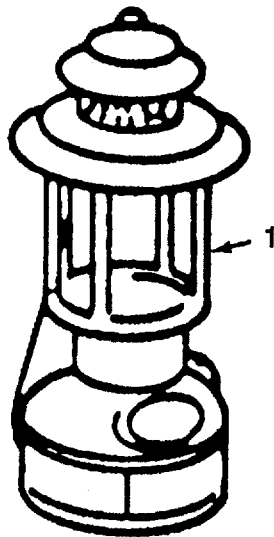

Figure F-2. Lantern, Gasoline

SECTION II

TM10-7360-208-13&P

(1) ITEM NO	(2) SMR CODE	(3) CAGEC	(4) PART NUMBER	(5) DESCRIPTION AND USABLE ON CODES (UOG)	(6) QTY
				GROUP 02 LATERN, GASOLINE	
				FIG. F-2 LATERN, GASOLINE	
1	PAOZZ	58536	A-A-52078	LANTERN, GASOLINE.....	3

END OF FIGURE

1  
|  
2 thru 4

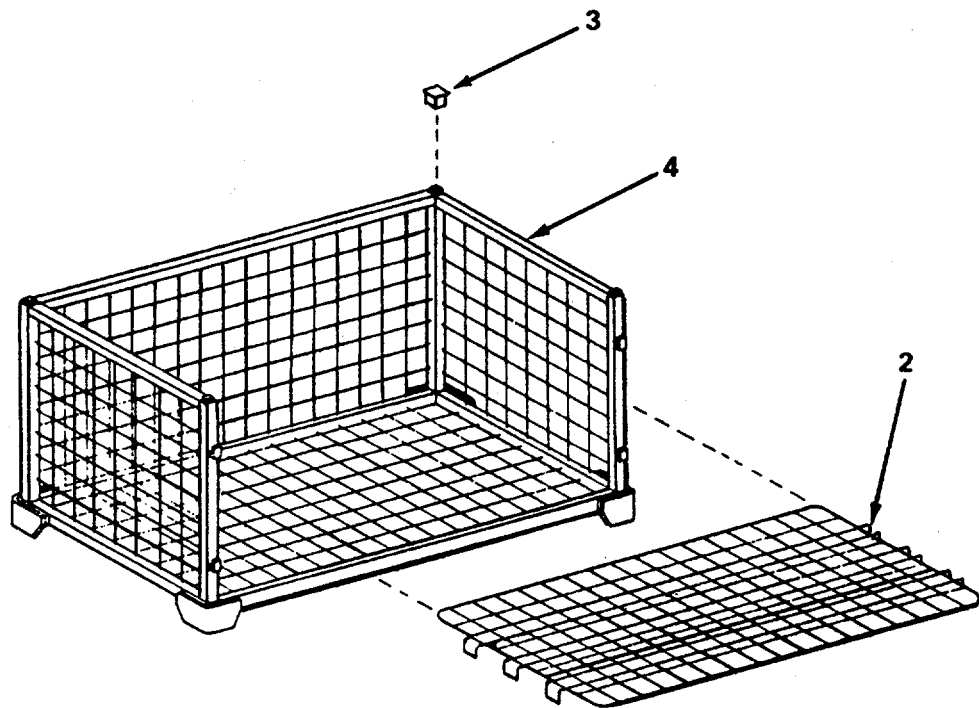

Figure F-3. Storage Rack Assembly

SECTION II  
 (1) (2) (3) TM10-7360-208-13&P C01 (4) (5) (6)  
 ITEM SMR  
 NO CODE CAGEC PART NUMBER DESCRIPTION AND USABLE ON CODES (UOG) QTY

GROUP 03 RACK ASSEMBLY, STORAGE

FIG. F-3 STRORAGE RACK ASSEMBLY

* 1	PBOFF	81337	5-13-4050	STORAGE RACK ASSEMB GE .....	1
* 2	PBOFF	81337	5-13-4053	.SHELF,STORAGE AND D.....	1
* 3	PBOZZ	99017	FP-166	.PLUG,PROTECTIVE,DUS.....	8
* 4	PBOFF	81337	5-13-4051	.RACK,STORAGE,KITCHE .....	1

END OF FIGURE





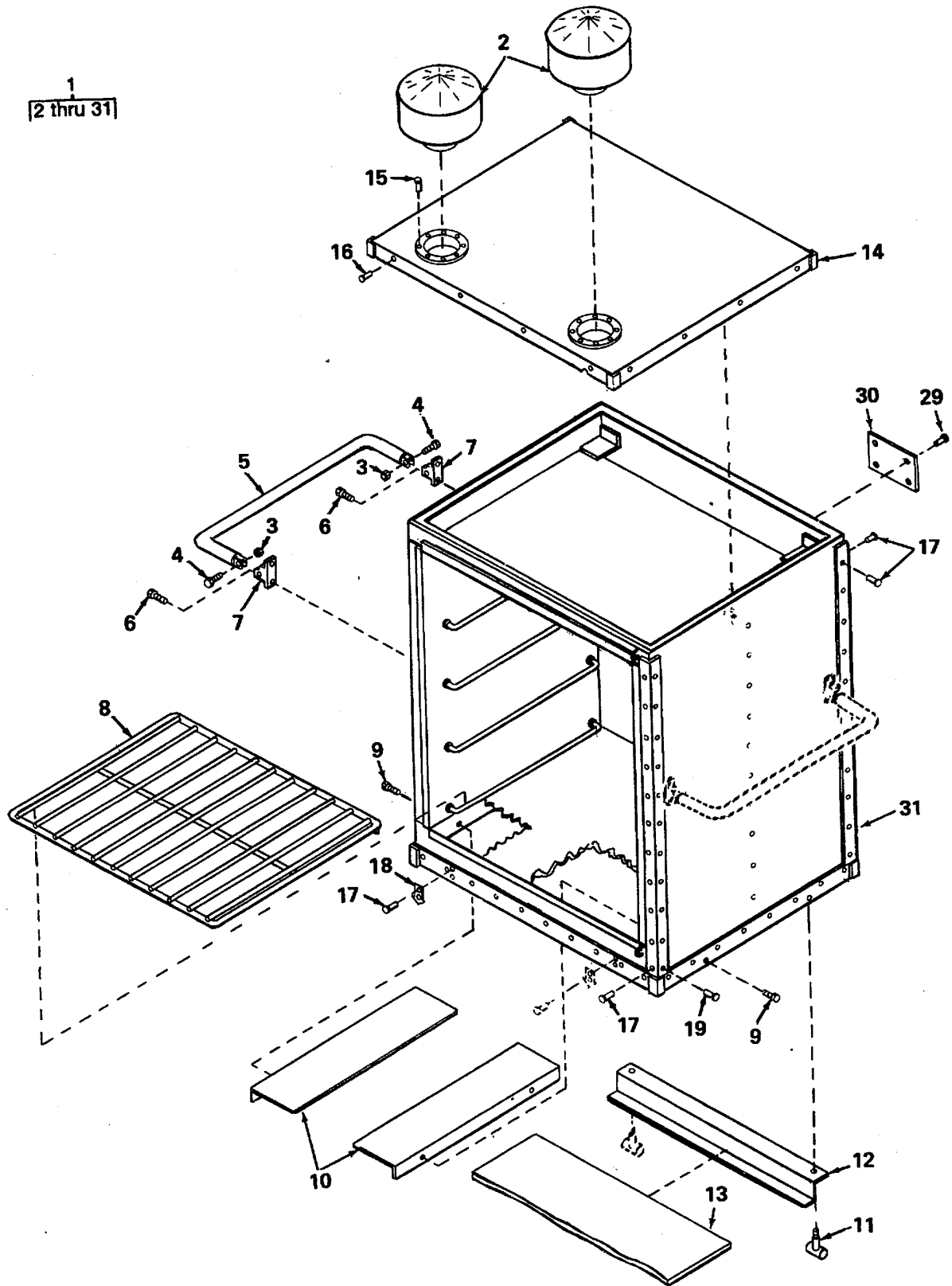

Figure F-4. Oven Assembly (Sheet 1 of 2)

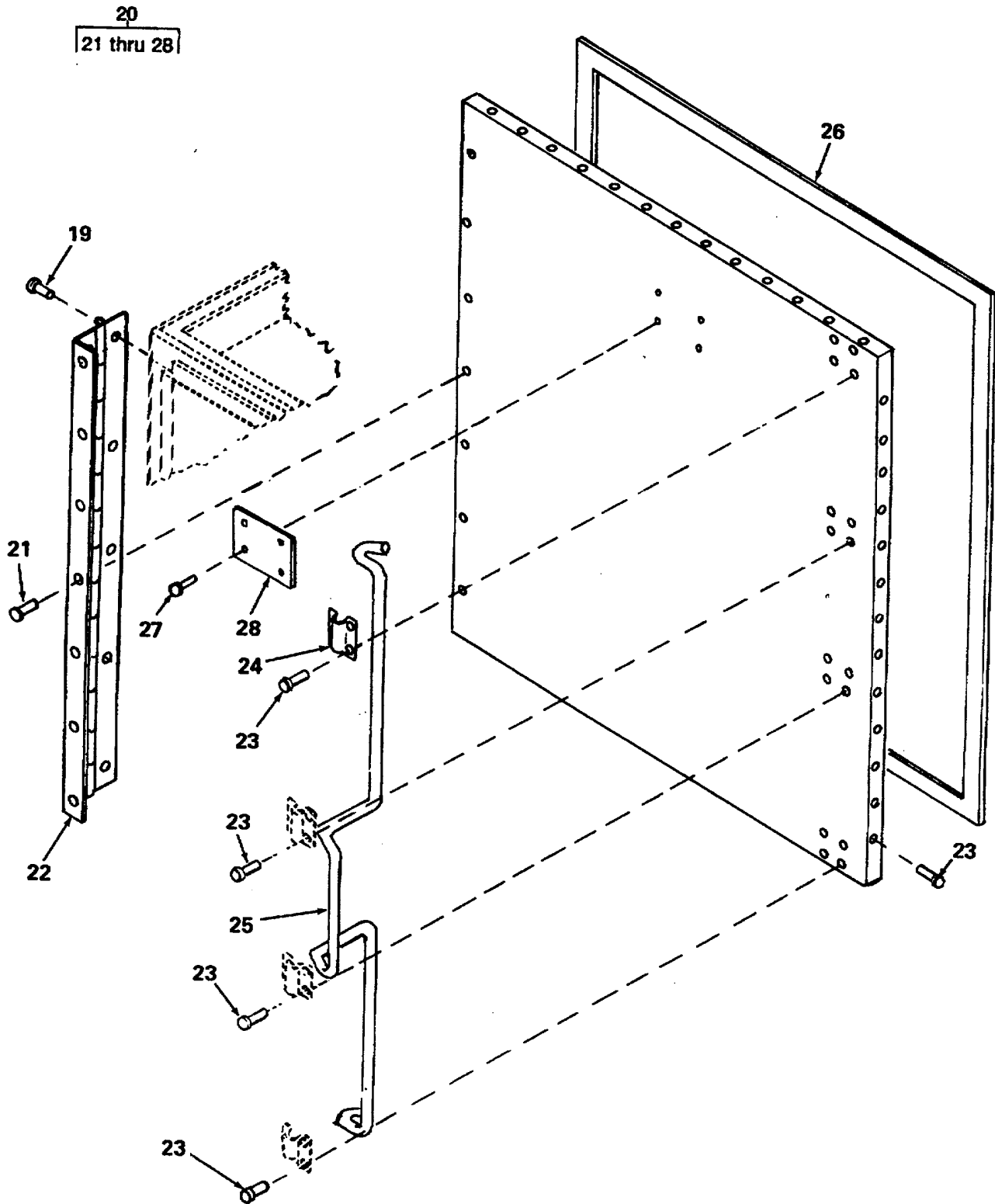

Figure F-4. Oven Assembly (Sheet 2 of 2)

## SECTION II

TM10-7360-208-13&amp;P C01

(1) ITEM NO	(2) SMR CODE	(3) CAGEC	(4) PART NUMBER	(5) DESCRIPTION AND USABLE ON CODES (UOG)	(6) QTY
GROUP 04 OVEN ASSEMBLY					
FIG. F-4 OVEN ASSEMBLY					
*	1	PBOFF	81337 5-13-4100	OVEN ASSEMBLY .....	2
*	2	PAOZZ	81337 5-13-4110	.CAP,FILLER OPENING .....	2
*	3	PAOZZ	96906 MS51922-2	.NUT,SELF- LOCKING,HE .....	4
*	4	PAOZZ	96906 MS35307-310	.SCREW,CAP,HEXAGON H.....	4
*	5	PAOZZ	81337 5-13-4108	.HANDLE,BOW,BOW .....	2
*	6	PAOZZ	96906 MS35307-306	.SCREW,CAP,HEXAGON H.....	8
*	7	XDOZZ	81337 5-13-4171	.HOLDER,HANDLE .....	2
*	8	PAOZF	81337 5-13-4101	.RACK,OVEN .....	4
*	9	PAOZZ	96906 MS51957-30	.SCREW,MACHINE.....	4
*	10	XDOZZ	81337 5-13-4174	.DEFLECTOR.....	2
*	11	XDOZZ	81337 5-13-4165	.T-BOLT .....	2
*	12	XDOZZ	81337 5-13-4117	.BRACKETINSULATION .....	1
*	13	MOOZZ	81337 5-13-4100-24	.INSULATION MAKE FROM..... CAGEC(75165)TYPE126 CERAFORM BOARD, 0.50 THK,CUT TO 19-13/16 X 23-7/8 IN .....	1
*	14	XDFFF	81337 5-13-4106	.OVEN TOP ASSEMBLY .....	1
*	15	PAFZZ	81349 M24243/1-B402	..RIVET,BLIND .....	16
*	16	PAFZZ	81349 M24243/1-B404	..RIVET,BLIND .....	16
*	17	PAFZZ	81349 M24243/1-B404	..RIVET BLIND .....	92
*	18	XDFZZ	81337 5-13-4172	.MARKER.....	2
*	19	PAFZZ	81349 M24243/1-B606	..RIVET,BLIND .....	37
*	20	XDFFF	81337 5-13-4104	.DOOR ASSEM BLY,OVEN.....	1
*	21	PAFZZ	81349 M24243/1-A606	..RIVET,BLIND .....	10
*	22	XAFZZ	81337 5-13-4186	..HINGE .....	1
*	23	PAFZZ	81349 M24243/1-B404	..RIVET,BLIND .....	61
*	24	XDFZZ	81337 5-13-4169	..BRACKET,HANDLE .....	4
*	25	XDFZZ	81337 5-13-4170	..HANDLE,LOCKING .....	1
*	26	MOOZZ	81337 5-13-4141	..GASKET,DOOR MAKE FROM P/N GW604-..... 1/4 X 1 INCH 10 FT REQUIRED (USED ON FIRST PRODUCTION OVEN DOORS ONLY.) .....	1
*	27	PAFZZ	81349 M24243/1-B403	..RIVET,BLIND .....	4
*	28	PAFZZ	81337 5-13-3773	..SIGN .....	1
*	29	PAFZZ	81349 M24243/1-B403	..RIVET,BLIND .....	4
*	30	PAFZZ	81337 5-13-3773	..SIGN .....	1
*	31	XAFZZ	32682 5-13-4100CABINET	..CABINET,OVEN.....	1

END OF FIGURE

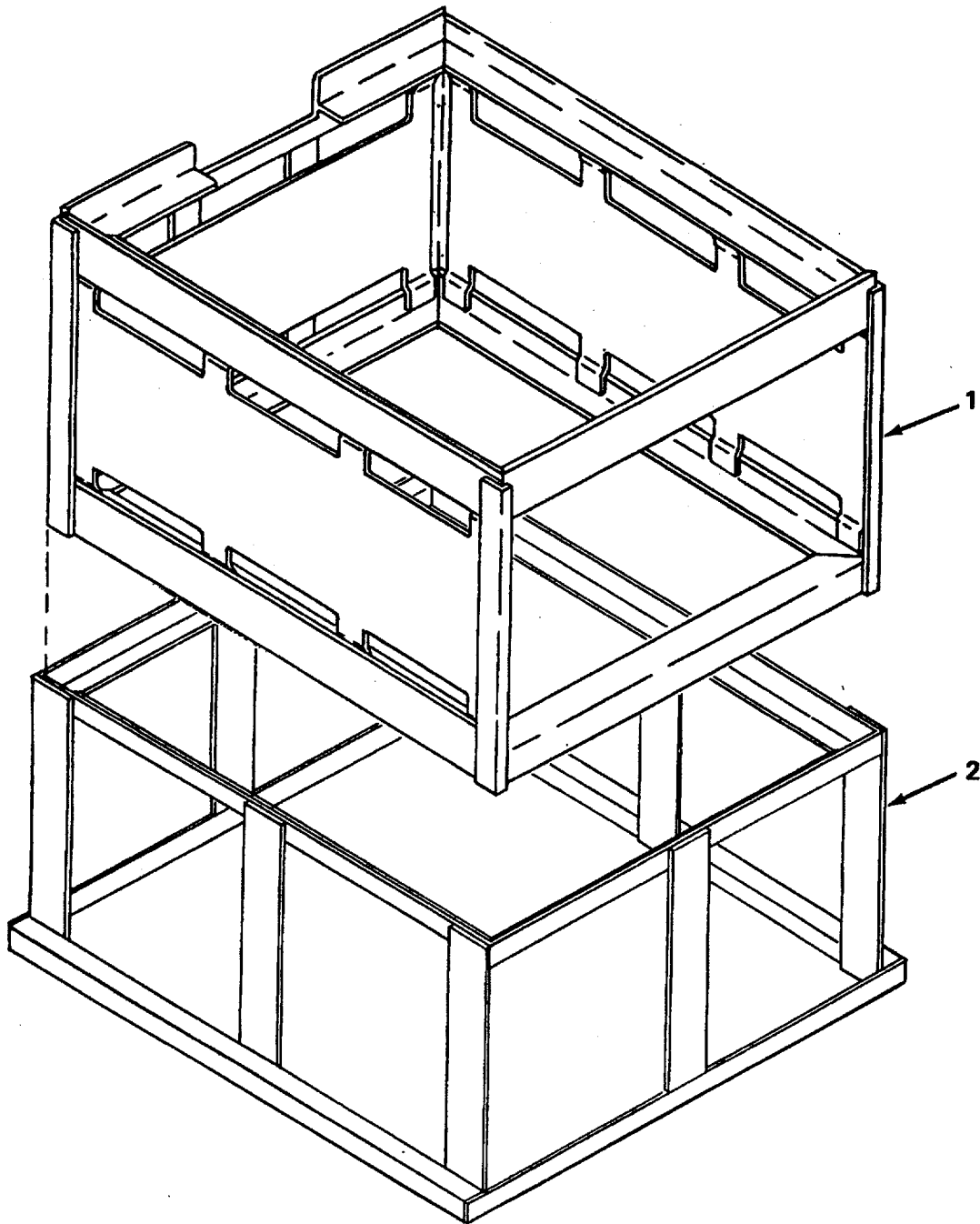

Figure F-5. Rack, Burner and Rack, Base

SECTION II  
 (1) (2) (3) TM10-7360-208-13&P C01 (6)  
 ITEM SMR  
 NO CODE CAGEC PART NUMBER DESCRIPTION AND USABLE ON CODES (UOG) QTY

GROUPS 05 AND 06 RACKS, BURNER AND BASE

FIG. F-5 RACK, BURNER AND RACK BASE

*	1	PBOFF	81337	5-13-3875	RACK, BURNER.....	2
*	2	PBOFF	81337	5-13-3868	RACK, BASE.....	2

END OF FIGURE

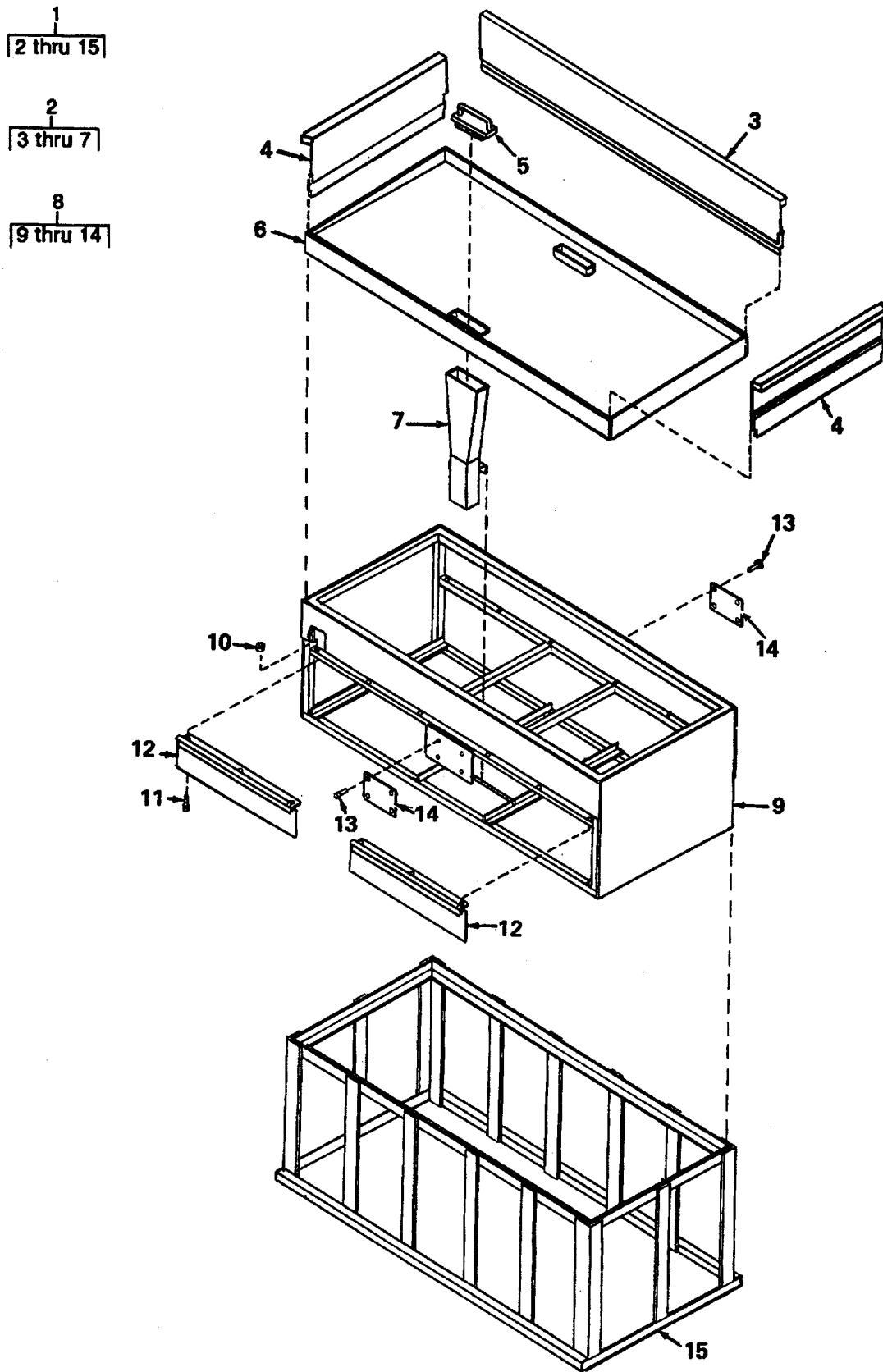

Figure F-6. Griddle Assembly

## SECTION II

TM10-7360-208-13&amp;P C01

(1) ITEM NO	(2) SMR CODE	(3) CAGEC	(4) PART NUMBER	(5) DESCRIPTION AND USABLE ON CODES (UOG)	(6) QTY
GROUP 07 GRIDDLE ASSEMBLY					
FIG. F-6 GRIDDLE ASSEMBLY					
*	1	PBOFF	81337 5-13-4210	GRIDDLE,SELF HEATIN.....	1
*	2	XDOOO	81337 5-13-4235	.GRIDDLE TOP ASSY.....	1
*	3	PBOZZ	81337 5-13-4238	..GUARD,SPL ASH,LONG .....	1
*	4	PBOZZ	81337 5-13-4237	..GUARD,SPLASH ,SHORT .....	2
*	5	PBOZZ	81337 5-13-4239	..PLUG,PROTECTIVE,DUS.....	1
*	6	PBOZZ	81337 5-13-4211	..GRIDDLE .....	1
*	7	PBOZZ	81337 5-13-4236	..CHUTE,GREASE .....	1
*	8	PBOFF	81337 5-13-4218	.RACK,BURNER,DOUBLE .....	1
*	9	XAFZZ	81337 5-13-4219	..FRAME ASSEMBLY.....	1
*	10	PAOZZ	96906 MS51972-1	...NUT,PLAIN,HEXAGON. ....	6
*	11	PAOZZ	96906 MS35308-310	...SCREW,CAP,HEXAGON H.....	6
*	12	XDOZZ	81337 5-13-4228	...GUARD,HEAT .....	2
*	13	PAFZZ	81349 M24243/1-B402	...RIVETR, BLIND.....	8
*	14	PAFZZ	81337 5-13-3773	...SIGN .....	2
*	15	PBOFF	81337 5-13-4230	RACK,BASE,DOUBLE BURNER.....	1

END OF FIGURE

1  
2 thru 13

6  
7 thru 12

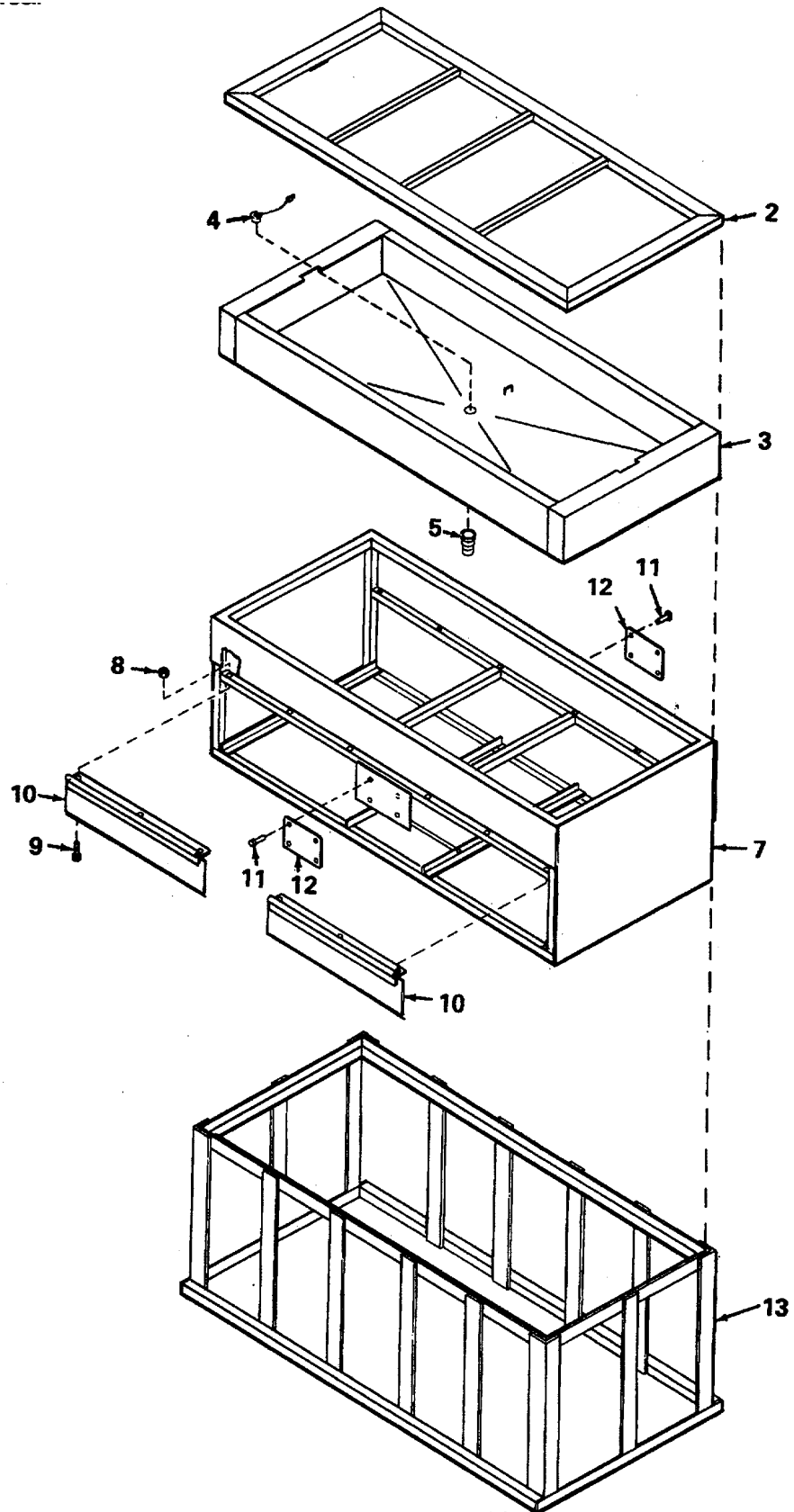

Figure F-7. Steam Table Assembly



## SECTION II

TM10-7360-208-13&amp;P C01

(1) ITEM NO	(2) SMR CODE	(3) CAGEC	(4) PART NUMBER	(5) DESCRIPTION AND USABLE ON CODES (UOG)	(6) QTY
-------------------	--------------------	--------------	-----------------------	--	------------

## GROUP 08 STEAM TABLE ASSEMBLY

## FIG. F-7 STEAM TABLE ASSEMBLY

*	1	PBOFF	81337 5-13-4212	STEAM TABLE Y .....	1
*	2	XDOFF	81337 5-13-4254	.ADAPTER, TOP .....	1
*	3	XDOFF	81337 5-13-4213	.BODY, STEAM TABLE .....	1
*	4	PBFZZ	81337 5-13-3744	..PLUG, PROTECTIVE, DUS.....	1
*	5	XDOZZ	96906 MS27020-8	..COUPLING HALF .....	1
*	6	PBOFF	81337 5-13-4218	.RACK, BURNER, DOUBLE .....	1
*	7	XAFZZ	81337 5-13-4219	..FRAME ASSEMBLY .....	1
*	8	PAOZZ	96906 MS51972-1	...NUT, PLAIN, HEXAGON .....	6
*	9	PAOZZ	96906 MS35308-310	...SCREW, CAP, HEXAGON H.....	6
*	10	XDOZZ	81337 5-13-4228	...GUARD, HEAT .....	2
*	11	PAFZZ	81349 M24243/1-B402	...RIVET, BLIND .....	8
*	12	PAFZZ	81337 5-13-3773	...SIGN .....	2
*	13	PBOFF	81337 5-13-4230	.RACK, BASE, DOUBLE BU.....	1

END OF FIGURE

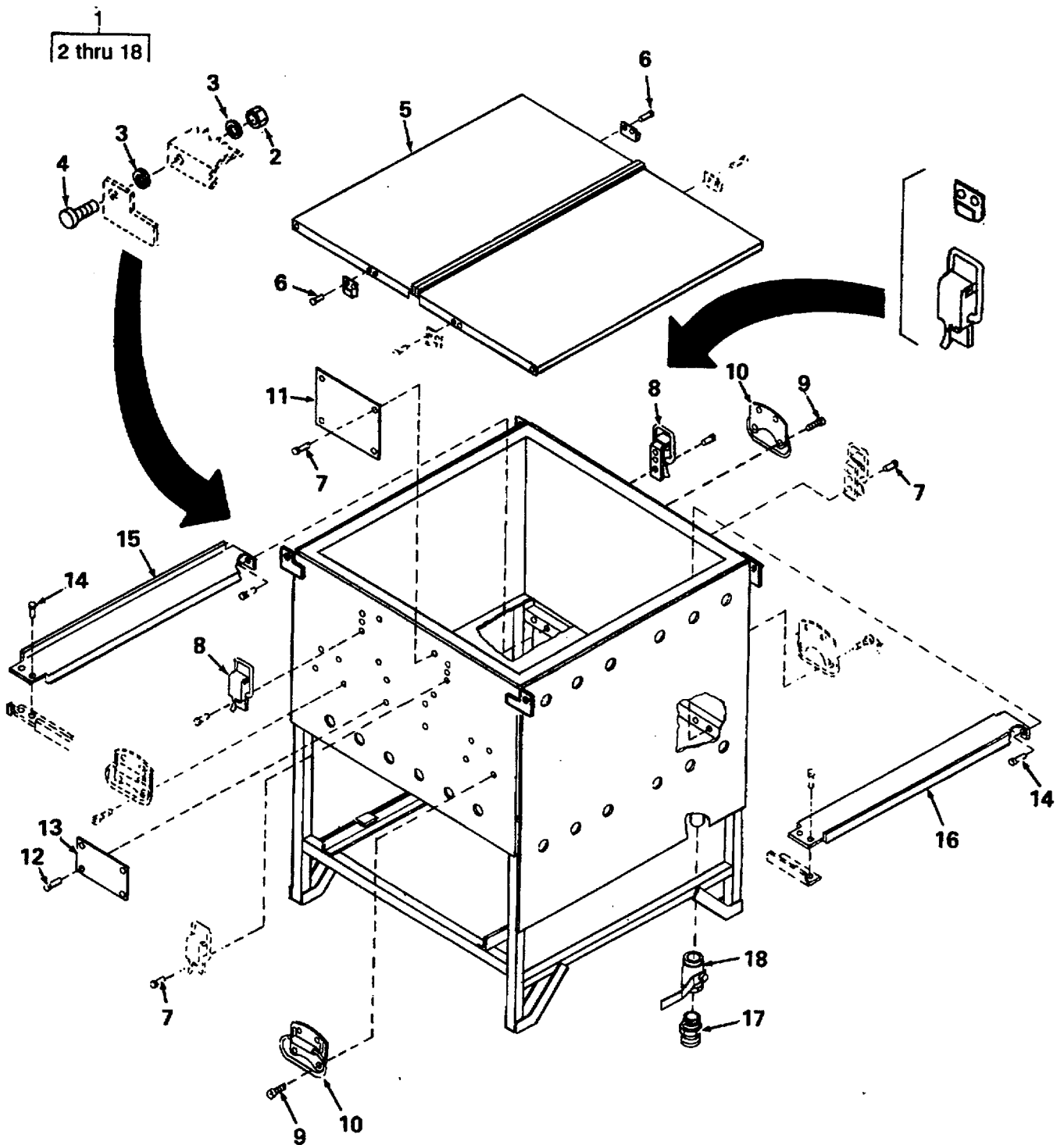

Figure F-8. Heater Tank Assembly

## SECTION II

TM10-7360-208-13&amp;P C01

(1) ITEM NO	(2) SMR CODE	(3) CAGEC	(4) PART NUMBER	(5) DESCRIPTION AND USABLE ON CODES (UOG)	(6) QTY
GROUP 09 HEATER TANK ASSEMBLY					
FIG. F-8 HEATER TANK ASSEMBLY					
*	1	PBOFF	81337 5-13-3721	TANK ASSEMBLY, HEATE .....	1
*	2	PAOZZ	96906 MS17830-4C	.NUT, SELF-LOCKING, HE .....	4
*	3	PAOZZ	88044 AN960-C416	.WASHER, FLAT .....	8
*	4	PAOZZ	96906 MS35307-306	.SCREW, CAP, HEXAGON H.....	4
*	5	PBFFF	81337 5-13-3732	.COVER, TANK, TRAY-PAC .....	2
*	6	PAFZA	96906 MS20426A6-5	.RIVET, SOLID .....	8
*	7	PAFZZ	96906 MS20604-B6W4	.RIVET, BLIND .....	12
*	8	PAFZZ	14608 641-US2G	.CATCH, FRICTION .....	4
*	9	PAOZA	96906 MS24628-64	.SCREW, TAPPING .....	8
*	10	PAOZZ	96906 MS35791-2	.HANDLE, BAIL .....	4
*	11	PAFZZ	81337 5-13-3771	.PLATE, INSTRUCTION .....	1
*	12	PAFZZ	81349 M24243/1-B403	.RIVET, BLIND .....	16
*	13	PAFZZ	81337 5-13-3773	.SIGN .....	2
*	14	PAFZZ	96906 MS24662-173	.RIVET, BLIND .....	8
*	15	XDFZZ	81337 5-13-3769	.REFLECTOR, HEAT, LH .....	1
*	16	XDFZZ	81337 5-13-3733	.REFLECTOR, HEAT, RH .....	1
*	17	PAOZZ	81337 5-13-3753	.ADAPTER, STRAIGHT, PI E .....	1
*	18	PAOZZ	98991 4211T3-4	.VALVE, BALL .....	1

END OF FIGURE

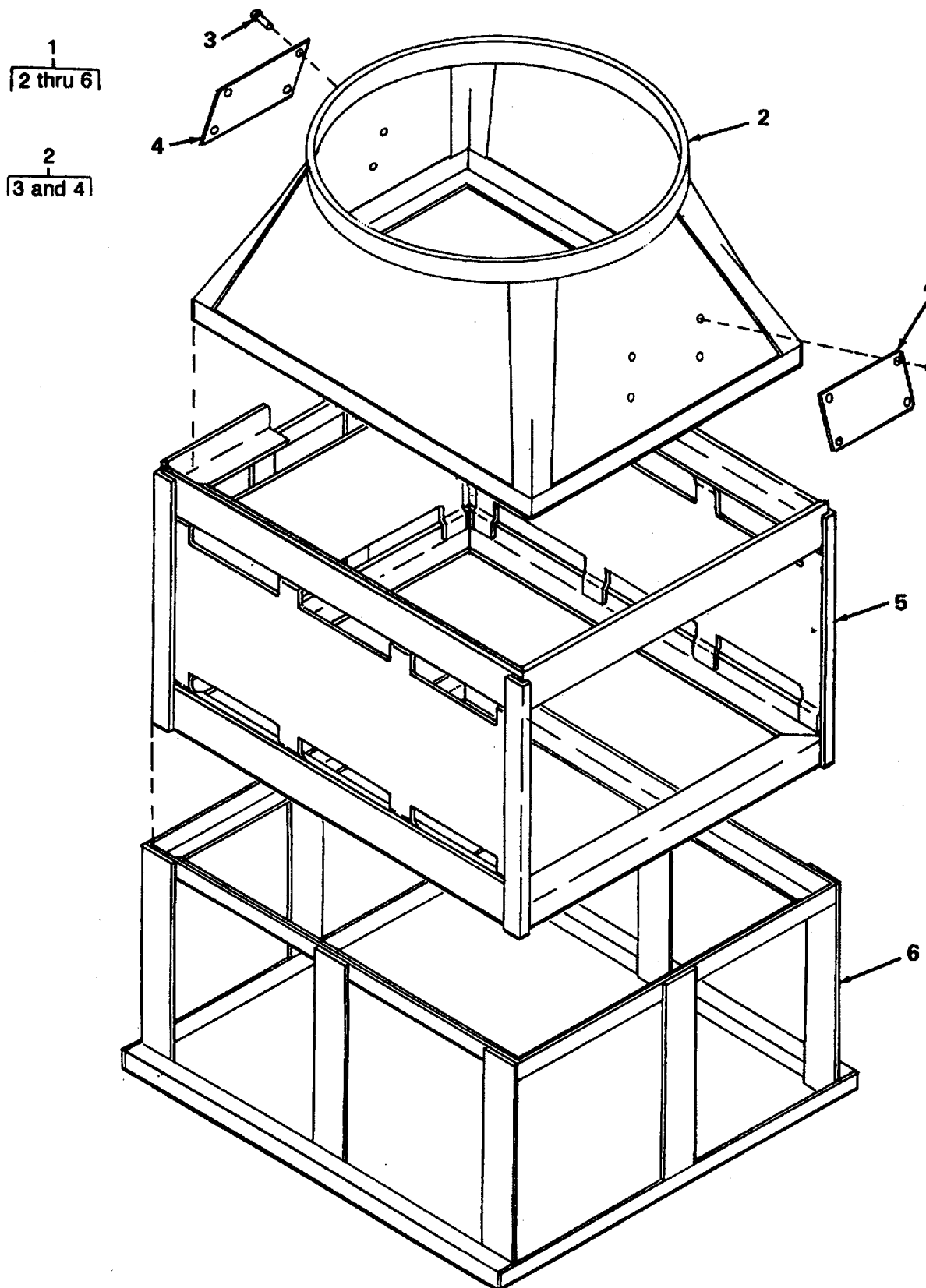

Figure F-9. Cooking Pot Cradle Assembly

SECTION II		TM10-7360-208-13&P C01			
(1)	(2)	(3)	(4)	(5)	(6)
ITEM NO	SMR CODE	CAGEC	PART NUMBER	DESCRIPTION AND USABLE ON CODES (UOG)	QTY
GROUP 10 COOKING POT CRADLE ASSEMBLY					
FIG. F-9 COOKING POT CRADLE ASSEMBLY					
*	1	PBOFF	81337	5-13-3991	CRADLE ASSEMBLY,COO ASSEMBLY ..... 2
*	2	PBOFF	81337	5-13-3886	.CRADLE,COOKING POT ..... 1
*	3	PAFZZ	81349	M24243/6-A401H	..RIVET,BLIND ..... 8
*	4	PAFZZ	81337	5-13-3773	..SIGN ..... 2
*	5	PBOFF	81337	5-13-3875	.RACK,BURNER..... 1
*	6	PBOFF	81337	5-13-3868	.RACK,BASE..... 1

END OF FIGURE

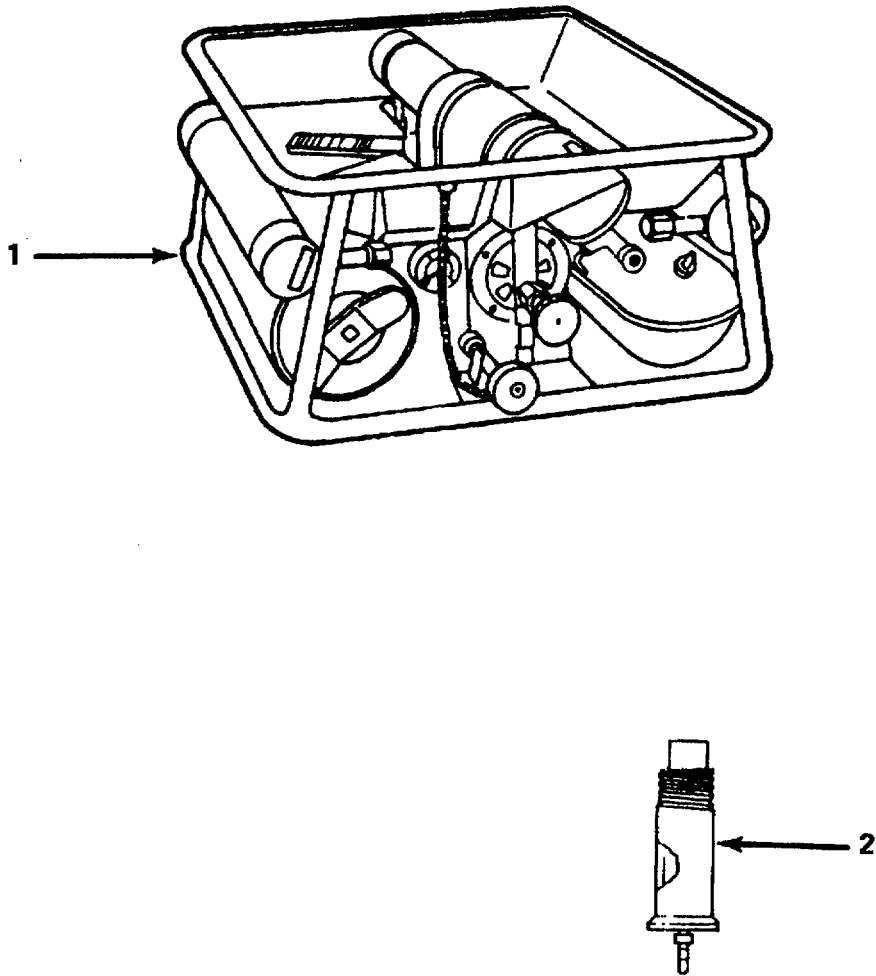

Figure F-10. M2 Burner Unit and Preheater Generator

SECTION II  
 (1) (2) (3) TM10-7360-208-13&P C01 (6)  
 ITEM SMR (4) (5)  
 NO CODE CAGEC PART NUMBER DESCRIPTION AND USABLE ON CODES (UOG) QTY

GROUP 11 BURNER UNIT, M2A

FIG. F-10 M2 BURNER UNIT AND  
 PRE-HEATER GENERATOR

*	1	PAOOO	81349	MIL-B-40098	BURNER UNIT,GASOLIN E .....	6
*	2	PAOZZ	81337	5-11-1232 5-10	PIECE PREHEATER,GENERATOR .....	6

END OF FIGURE

1  
[2 thru 4]

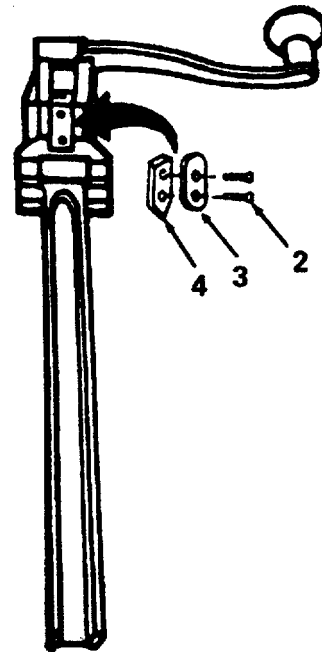

Figure F-11. Opener, Can, Mounted



SECTION II  
 (1) (2) (3) TM10-7360-208-13&P C01 (4) (5) (6)  
 ITEM SMR CAGEC PART DESCRIPTION AND USABLE ON CODES (UOG) QTY  
 NO CODE NUMBER

GROUP 12 OPENER, CAN, MOUNTED

FIG. F-11 OPENER, CAN, MOUNTED

*	1	PAOOO	81337	5-13-3969	OPENER,CAN,MOUNTED .....	2
*	2	PAOZZ	96906	MS51957-62	.SCREW,M ACHI NE .....	2
*	3	PAOZZ	83190	I SUPPORT PLATE	.I SUPPORT PLATE .....	1
*	4	PAOZZ	83190	K004	.BLADE,MOUNTED CAN O R .....	1

END OF FIGURE

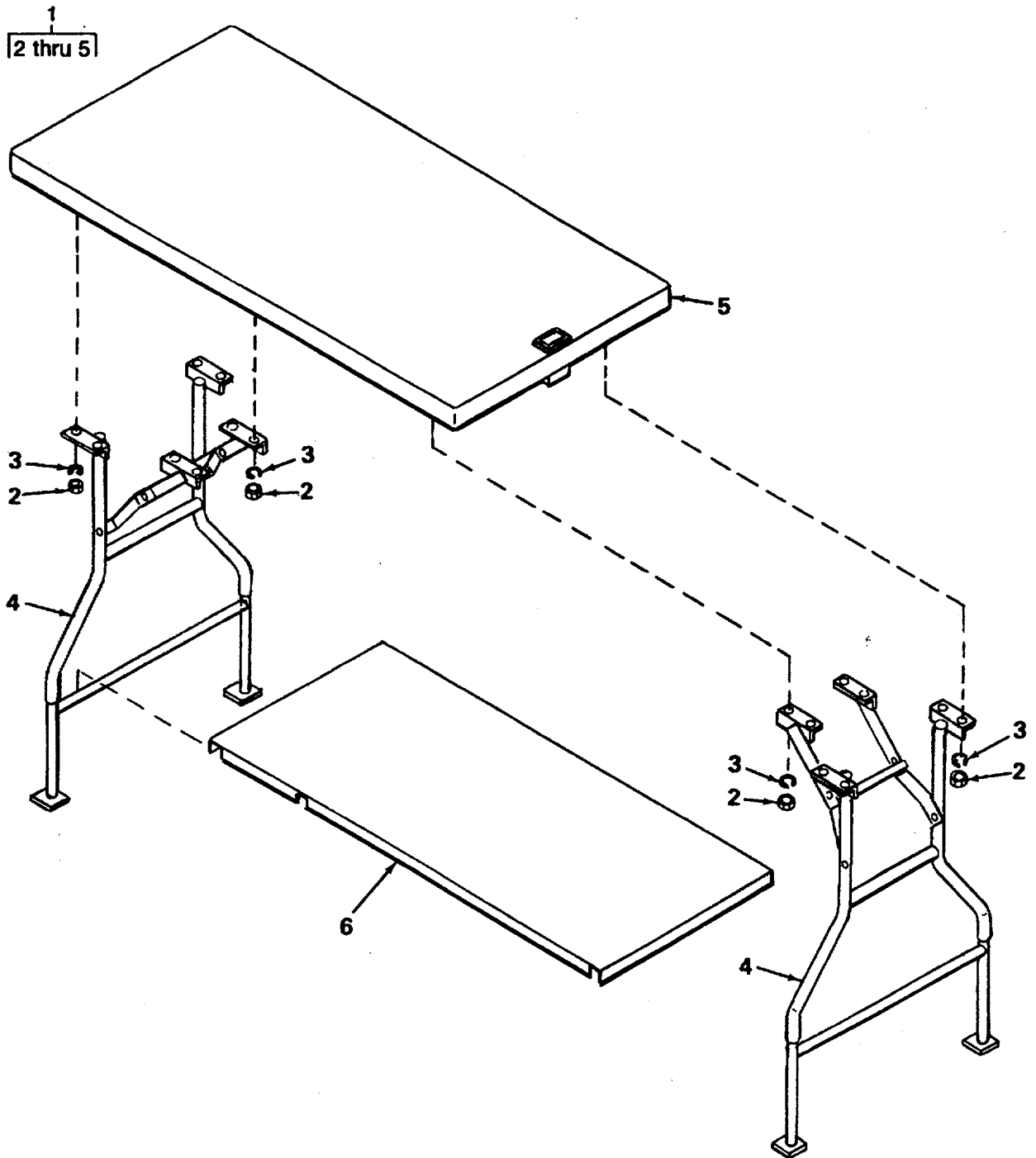

Figure F-12. Table, Folding Leg and Shelf

## SECTION II

TM10-7360-208-13&amp;PC01

(1) ITEM NO	(2) SMR CODE	(3) CAGEC	(4) PART NUMBER	(5) DESCRIPTION AND USABLE ON CODES(UOC)	(6) QTY
				GROUP 13 TABLE, FOLDING LEG	
				FIG. F-12 TABLE, FOLDING LEG AND SHELF	
* 1	PBOFF	81337	5-13-4242	TABLE,FOLDING LEGS .....	2
* 2	PAOZZ	96906	MS51971-1	.NUT,PLAIN, HEXAGON .....	16
* 3	PAOZZ	96906	MS35335-61	.WASHER,LOCK .....	16
* 4	PBOFF	81337	5-13-4245-1	.LEG ADAPTER ASSEMBL .....	2
* 5	XAOZZ	81337	5-13-4243	.TOP, TABLE .....	1
* 6	PBOZZ	81337	5-13-4257	COVER,ACCESS .....	2

END OF FIGURE

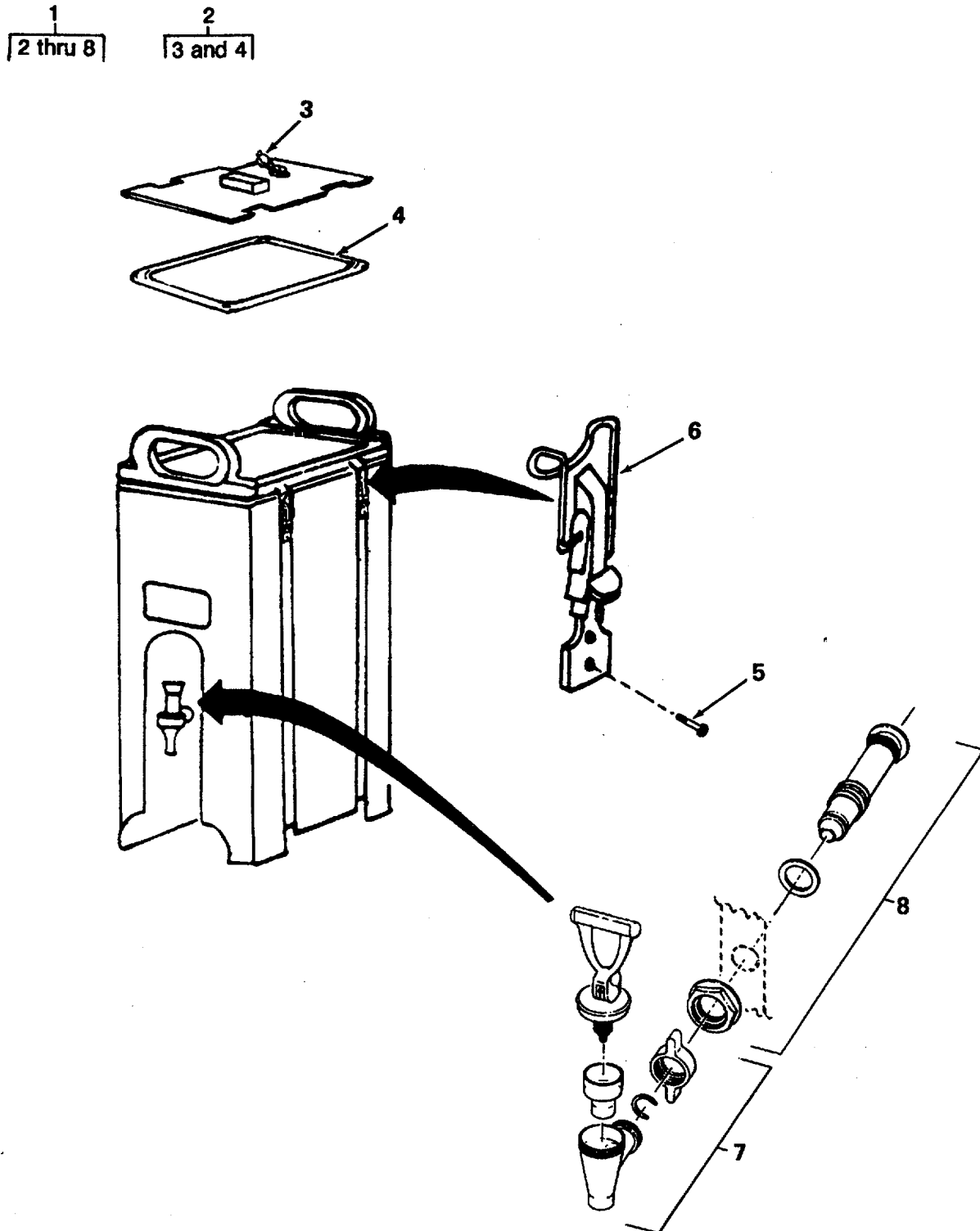

Figure F-13. Dispenser, Liquid, Insulated

## SECTION II

TM 10-7360-208-13&amp;P

C01

(1) ITEM NO	(2) SMR CODE	(3) CAGEC	(4) PART NUMBER	(5) DESCRIPTION AND USABLE ON CODES(UOC)	(6) QTY
				GROUP 14 DISPENSER, LIQUID	
				FIG. F-13 DISPENSER, LIQUID, INSULATED	
* 1	PAOOZ	21669	500LCD-G	DISPENSER,LIQUID,IN SULATED .....	17
* 2	PAOOO	21669	63226-G	.LID ASSEMBLY,LIQUID .....	1
* 3	PAOZZ	21669	14200	..CAP,VENT,DISPENSER .....	1
* 4	PAOZZ	21669	12101	..GASKET .....	1
* 5	PAOZZ	96906	MS51861-25C	.SCREW,TAPPING D .....	8
* 6	PAOZZ	21669	60028	.CATCH,FLUSH .....	4
* 7	PAOZZ	21669	46002	.FAUCET ASSEMBLY, POR .....	1
* 8	PAOZZ	21669	64003	.SPOUT ASSEMBLY,DISP .....	1

END OF FIGURE

1  
2 thru 8

6  
7 and 8

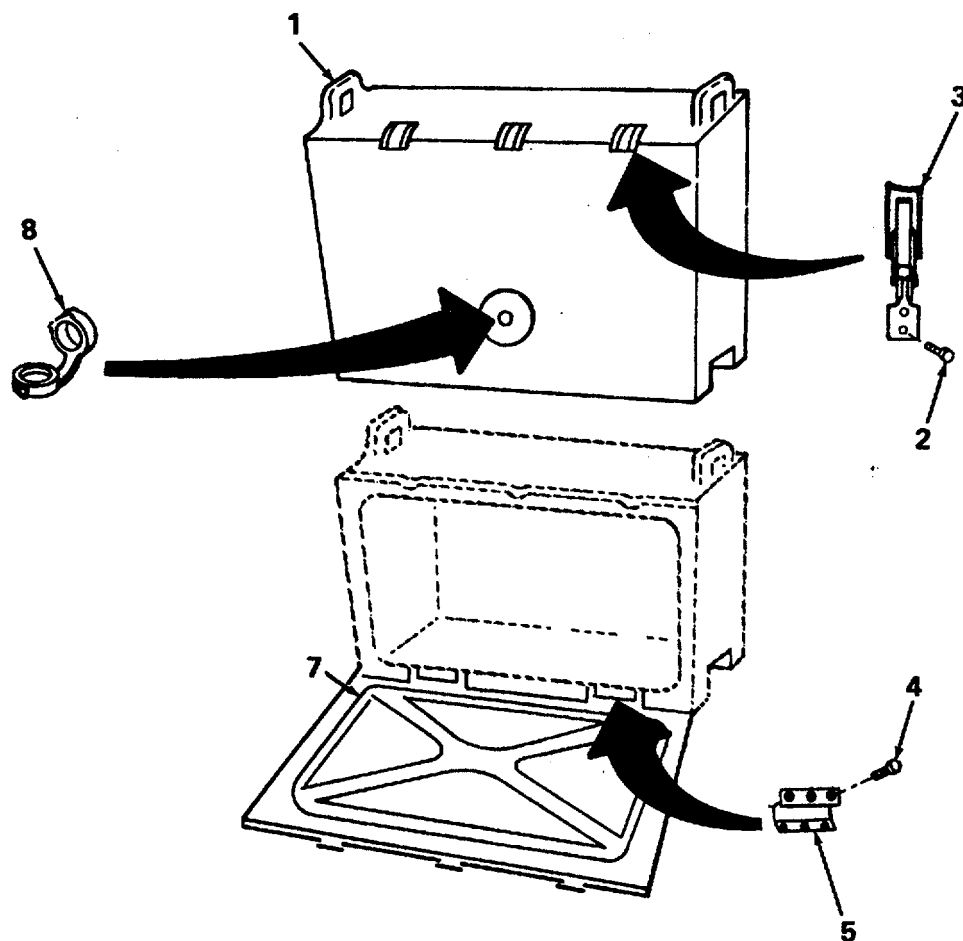

Figure F-14. Food Container, Insulated

## SECTION II

TM 10-7360-208-13&amp;P

C01

(1) ITEM NO	(2) SMR CODE	(3) CAGEC	(4) PART NUMBER	(5) DESCRIPTION AND USABLE ON CODES(UOC)	(6) QTY
				GROUP 15 FOOD CONTAINER, INSULATED	
				FIG. F-14 FOOD CONTAINER, INSULATED	
* 1	PAOOO	21669	200MPC1-G	FOOD CONTAINER,INSULATED .....	6
* 2	PAOZZ	96906	MS51861-26C	.SCREW,TAPPING D .....	6
* 3	PAOZZ	21669	60029	.CATCH,FLUSH .....	3
* 4	PAOZZ	96906	MS51958-61	.SCREW,MACHINE .....	12
* 5	PAOZZ	21669	60012	.HINGE,BUTT .....	2
* 6	PAOOO	21669	63416-G	.DOOR,FOOD CONTAINER. ....	1
* 7	PAOZZ	21669	12109	..GASKET .....	1
* 8	PAOZZ	21669	14200	..CAP,VENT ,DISPENSER, .....	1

END OF FIGURE

1  
2 thru 7

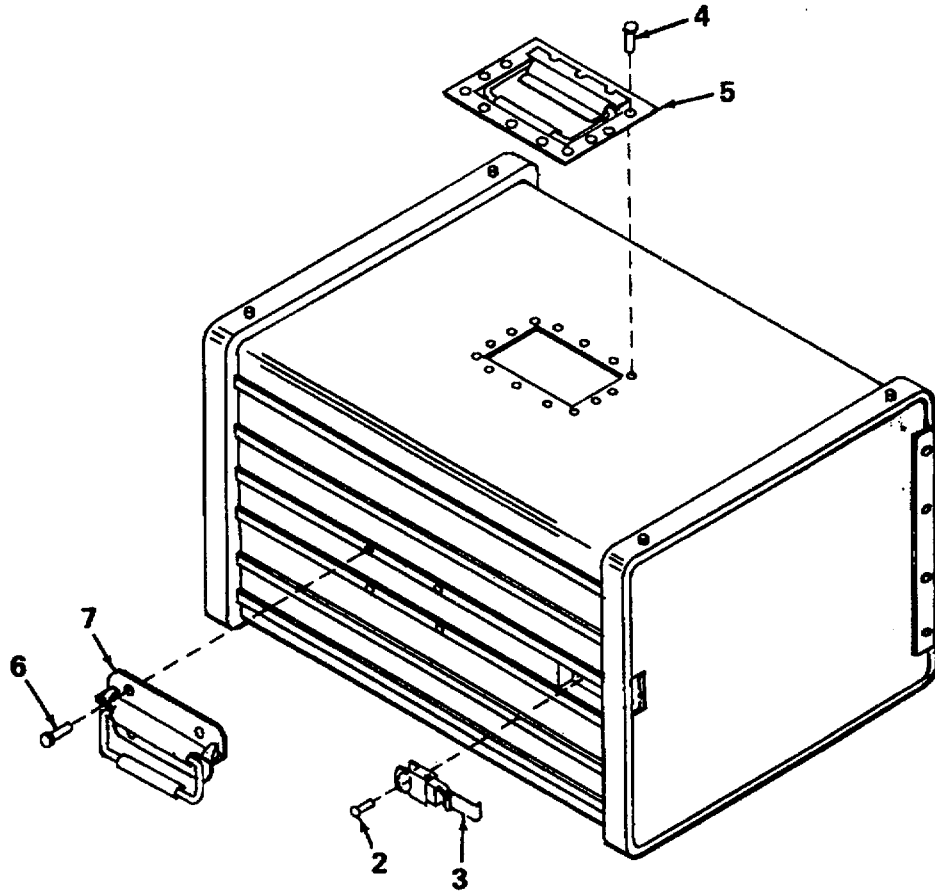

Figure F-15. Storage Cabinet



## SECTION II

TM 10-7360-208-13&amp;P C01

(1) ITEM NO	(2) SMR CODE	(3) CAGEC	(4) PART NUMBER	(5) DESCRIPTION AND USABLE ON CODES(UOC)	(6) QTY
-------------------	--------------------	--------------	-----------------------	---	------------

## GROUP 16 STORAGE CABINET

## FIG. F-15 STORAGE CABINET

* 1	PBOFF	81337	5-13-4160	CABINET,STORAGE .....	2
* 2	PAFZZ	96906	MS20426A4-4C	RIVETSOLID .....	3
* 3	PAFZZ	98003	3HC-83314-42-6	LATCH GUIDE,SNAPSLI .....	1
* 4	PAFZZ	96906	MS20470AD4-5C	RIVET,SOLID .....	14
* 5	XDFZZ	98003	H560-LS-2-RG	HANDLE, TOP .....	1
* 6	PAFZZ	96906	MS20470A6-SC	.RIVET,SOLID .....	10
* 7	XDFZZ	98003	HA956-LS-2-RG	HANDLE,SIDE .....	2

END OF FIGURE

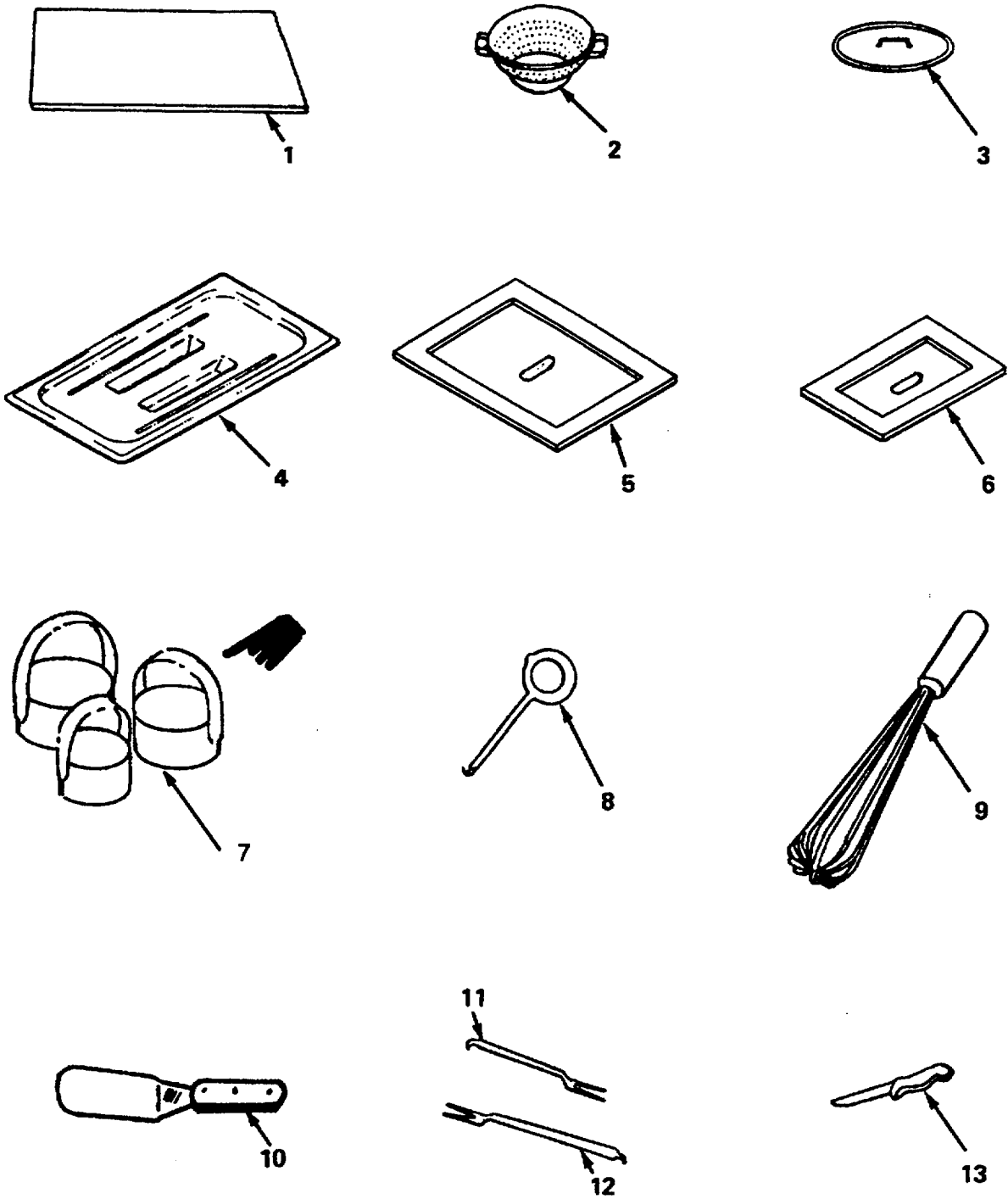

Figure F-16. Utensils (Sheet 1 of 5)

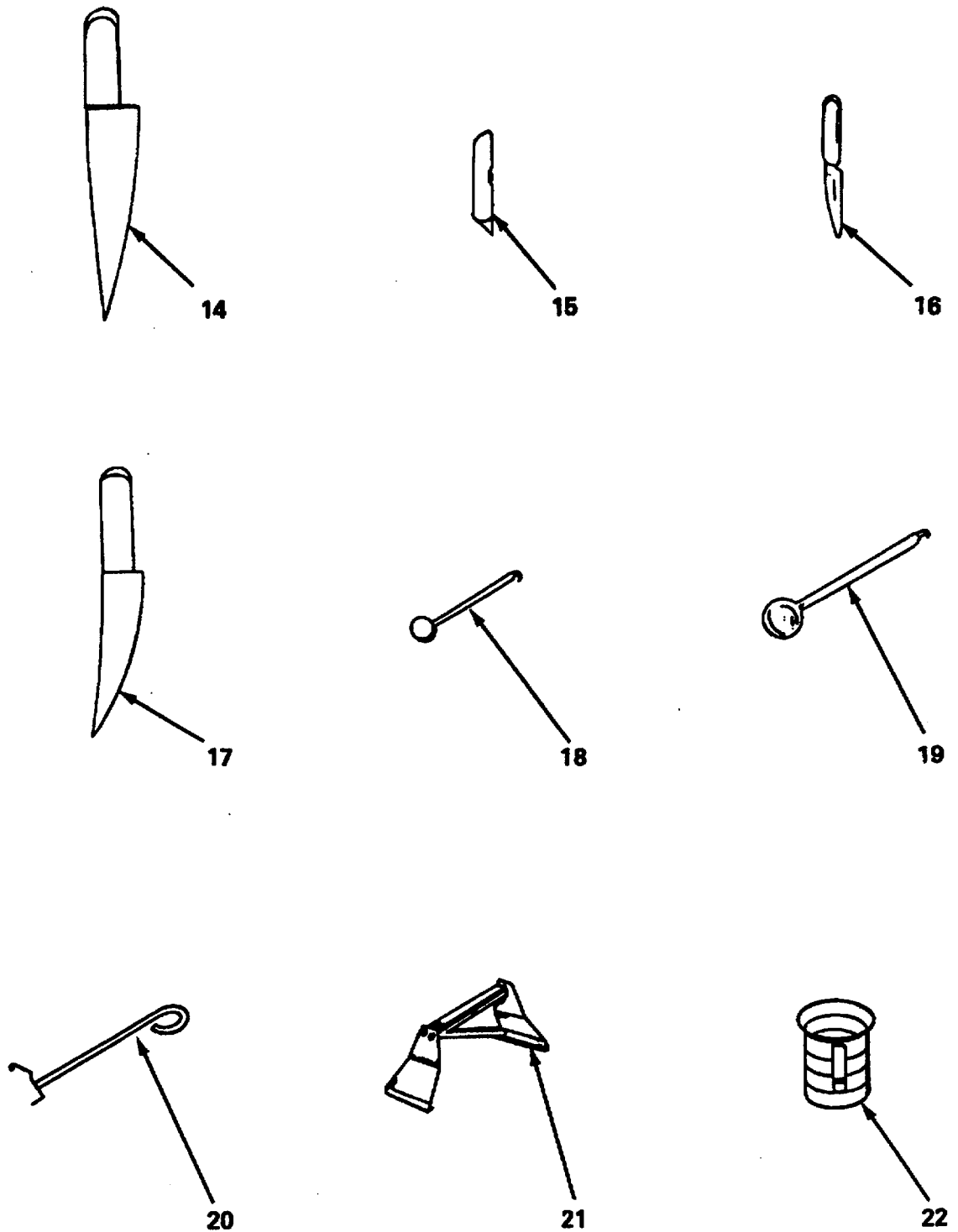

Figure F-16. Utensils (sheet 2 of 5)

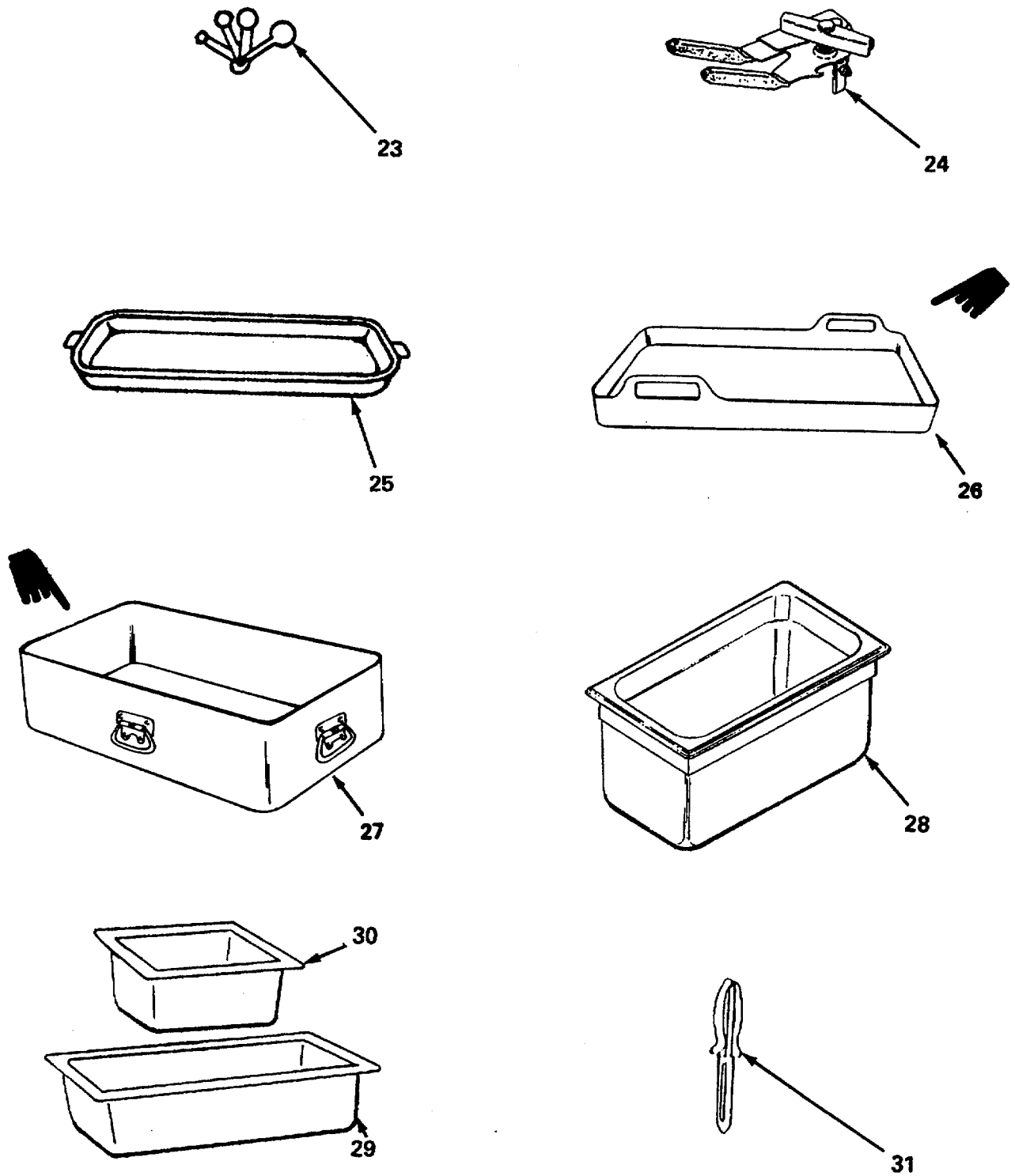

Figure F-16. Utensils (Sheet 3 of 5)

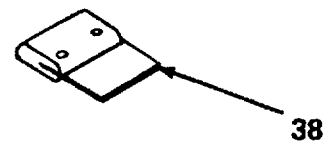
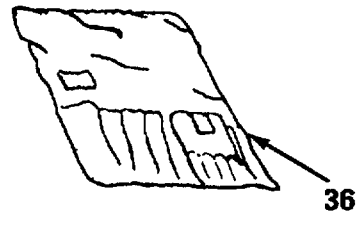
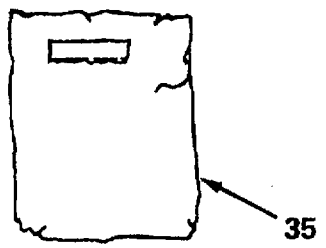
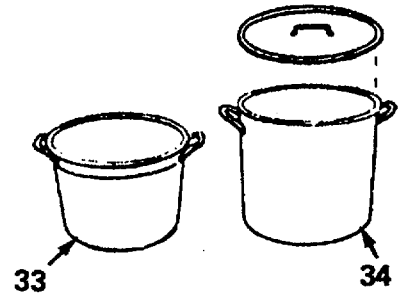
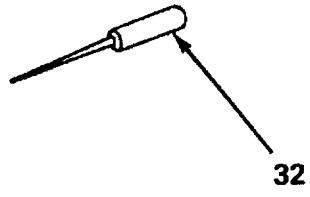

Figure F-16. Utensils (Sheet 4 of 5)

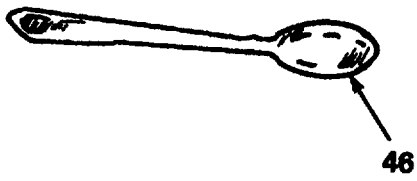
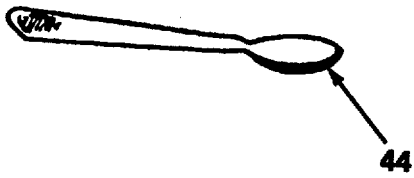
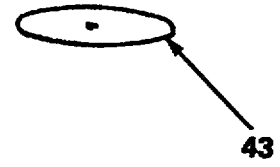
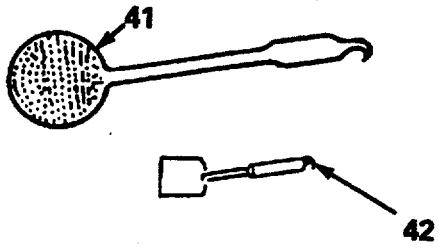

Figure F-16. Utensils (Sheet 5 of 5)

## SECTION II

TM 10-7360-208-13&amp;P

C01

(1) ITEM NO	(2) SMR CODE	(3) CAGEC	(4) PART NUMBER	(5) DESCRIPTION AND USABLE ON CODES(UOC)	(6) QTY
				GROUP 17 UTENSILS	
				FIG. F-16 UTENSILS	
	XAOZZ	19099	NO NUMBER	UTENSILS .....	1
* 1	PAOZZ	58536	A-A-391	.BOARD,FOOD CHOPPING .....	2
* 2	PAOZZ	80049	6921793900	.COLANDER .....	1
* 3	PAOZZ	81349	MIL-P-1735	.COVER,COOKING POT,R .....	4
* 4	PAOZZ	21669	MP-C-30-H	.COVER,PAN,FOOD SERVING AND .....	36
				STORAGE,RECTANGULAR.....	
* 5	PAOZZ	56023	FC-120	.COVER,STEAM TABLE P. ....	6
* 6	PAOZZ	56023	FC-280	.COVER,STEAM TABLE P S .....	6
* 7	PAOZZ	58536	A-A--50171	.CUTTER SET,COOKIE.....	1
* 8	PAOZZ	58536	A-A-1077	.DIPPER,KITCHEN.....	2
* 9	PAOZZ	58536	A-A-394	.EGG WHIP .....	1
* 10	PAOZZ	80244	MIL-U-10815 TY4S Z2	.FOOD TURNER.....	3
* 11	PAOZZ	80244	MIL-U-10815 TY1S Z1	.FORK,FOOD PREPARATION .....	3
* 12	PAOZZ	80244	MIL-U-10815 TYLS Z2	.FORK,FOOD PREPARATION .....	3
* 13	PAOZZ	4Y739	6447M	.KNIFE,BONING .....	2
* 14	PAOZZ	80244	GGG-C-746 TY20GR D	.KNIFE,COOKS .....	2
* 15	PAOZZ	80244	GGG-K-494TY2	.KNIFE,CRAFTSMANS .....	2
* 16	PAOZZ	80244	GGG-C-746 TYSGRD	.KNIFE,PARING.....	2
* 17	PAOZZ	80244	GGG-C-746 TY6GRD	.KNIFE,SLICING .....	1
* 18	PAOZZ	58536	A-A-1956	.LADLE,KITCHEN .....	2
* 19	PAOZZ	58536	A-A-1956	.LADLE,KITCHEN .....	2
* 20	PAOZZ	81337	5-13-3961	.LIFTER,TRAY-PACK .....	2
* 21	PAOZZ	81337	5-13-3859	.LIFTER,TRAY-PACK,SERVING .....	2
* 22	PAOZZ	58536	A-A-1751	.MEASURE,LIQUID ART .....	2
* 23	PAOZZ	58536	A-A-1954	.MEASURING SET,SPOON .....	2
* 24	PAOZZ	81337	5-13-3971	.OPENER,CAN,HAND .....	2
* 25	PAOZZ	81349	MIL-P-12851	.PAN,BAKING AND ROASTING .....	10
* 26	PAOZO	80244	MIL-P-1747TM2	.COVER,BAKING AND ROASTING PAN.....	5
* 27	PAOZZ	81349	MIL-P-1747	.PAN,BAKING AND ROASTING .....	5
* 28	PAOZZ	21669	MP36	.PAN,FOOD SERVING AND STORAGE.....	36
* 29	PAOZZ	56023	124	.PAN,STEAM TABLE .....	3
* 30	PAOZZ	56023	224	.PAN,STEAM TAB LE .....	6
* 31	PAOZZ	85812	W8079	.PEELER,POTATO,HAND .....	2
* 32	PAOZZ	58536	A-A-631	.PICK,ICE .....	1
* 33	PAOZZ	80244	MIL-P-1735 SZ1	.POT,COOKING .....	2
* 34	PAOZZ	80244	MIL-P-1735 SZ2	.POT,COOKING .....	2
* 35	PAOZZ	97074	PANHANDLER	.POT HOLDER.....	4
* 36	PAOZZ	81349	MIL-R-1982	.ROLL,CUTLERY.....	1
* 37	PAOZZ	58536	A-A-2368	.ROLLING PIN.....	1
* 38	PAOZZ	58536	A-A-52068	.SCRAPER,BAKER'S .....	1
* 39	PAOZZ	80244	GGG-C-746 TY21GR D	.SERVER,PIE AND CAKE .....	1
* 40	PAOZZ	58536	A-A-467	.SIFTER,FLO UR,HAND.....	1
* 41	PAOZZ	58536	A-A-1072	.SKIMMER,KITCHEN.....	2

## SECTION II

TM 10-7360-208-13&amp;P

C01

(1) ITEM NO	(2) SMR CODE	(3) CAGEC	(4) PART NUMBER	(5) DESCRIPTION AND USABLE ON CODES(UOC)	(6) QTY
* 42	PAOZZ	19099	NO REF	.SPATULA .....	2
* 43	PAOZZ	81337	2-9-120PT224	.SPLASH PLATE,COOKING .....	2
* 44	PAOZZ	58536	A-A-1082	.SPOON,FOOD SERVICE .....	4
* 45	PAOZZ	80244	MIL-U-10815 TY2S Z2	.SPOON,FOOD SERVICE .....	4
* 46	PAOZZ	58536	A-A-1082	.SPOON,FOOD SERVICE .....	8
* 47	PAOZZ	09647	838A7511	.SPOUT,CAN,FLEXIBLE.....	1
* 48	PAOZZ	64067	7330-00-616-0997	.TONGS,FOOD SERVING.....	3
* 49	PAOZZ	58536	A-A-295	.WASTE RECEPTACLE .....	2

END OF FIGURE





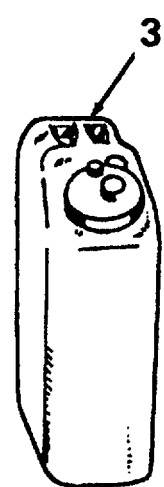
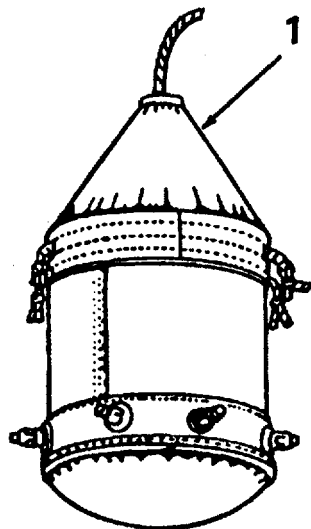

SECTION II

(1) ITEM NO	(2) SMR CODE	(3) CAGEC	(4) PART NUMBER	(5) DESCRIPTION AND USABLE ON CODES(UOC)	(6) QTY
GROUP 18 MISCELLANEOUS ASSEMBLIES					
BAG, DRINKING WATER STORAGE					
CAN, GASOLINE CAN AND WATER					
CAN					
FIG. F-17 BAG, DRINKING WATER STORAGE,					
GASOLINE CAN AND WATER CAN					
1	PAOZZ	81349	MILB273	BAG, WATER STERILIZATION .....	1
2	PAOZZ	81349	MIL-C-53109	CAN, GASOLINE, MILITARY .....	5
3	PAOZZ	81349	MIL-C-43613	CAN, WATER, MILITARY .....	5

END OF FIGURE

SECTION II

(1) ITEM NO	(2) SMR CODE	(3) CAGEC	(4) PART NUMBER	(5) DESCRIPTION AND USABLE ON CODES(UOC)	(6) QTY
GROUP 19 BULK FIG. BULK					
1	PAOZZ	75165	TYPE126CERA- FORM, 0.050THK, 24X481N	INSULATION BLANKET, CUT TO ..... 19-13/16X23-7/81NCH .....	V
2	PAOZZ	81851	GW604-1/4X11 INCH	GASKET (USED ON FIRST PRODUCTION OVEN DOORS ONLY) .....	V

END OF FIGURE

**SECTION III**  
**NOT APPLICABLE**



## CROSS-REFERENCE INDEXES

NATIONAL STOCK NUMBER INDEX					
STOCK NUMBER	FIG.	ITEM	STOCK NUMBER	FIG.	ITEM
5305-00-021-3668	F-4	4	5320-00-510-7823	F-4	15
5305-00-050-9228	F-11	2		F-6	13
5305-00-054-6654	F-4	9		F-7	11
5305-00-059-3657	F-14	4	5310-00-527-3634	F-12	3
7330-00-078-5706	F-16	1	5310-00-531-9515	F-8	3
7240-00-089-7312	F-17	3	7330-00-543-7097	F-16	7
5305-00-147-3232	F-14	2	5305-00-562-2750	F-8	9
7240-00-151-6629	F-16	49	7310-00-576-4614	F-16	30
7330-00-153-9749	F-16	37	7330-00-680-2635	F-16	41
6260-00-170-0430	F-2	1	5340-00-682-1502	F-8	10
7240-00-177-6154	F-16	47	5320-00-685-0273	F-8	6
7330-00-184-0089	F-16	40	5305-00-702-4523	F-4	6
7340-00-197-1271	F-16	13		F-8	4
7340-00-205-1421	F-16	46	7330-00-815-1458	F-16	9
7330-00-205-1950	F-16	38	7310-00-834-4480	F-16	5
7330-00-205-3096	F-16	22	7330-00-849-5194	F-16	42
7340-00-223-7791	F-16	11	5110-00-892-5071	F-16	15
7340-00-223-7792	F-16	12	4820-00-902-2829	F-8	18
7340-00-223-7800	F-16	45	5310-00-903-5966	F-12	2
7310-00-238-5164	F-16	29	5320-00-904-4136	F-4	27
7330-00-238-8316	F-16	31		F-4	29
7340-00-240-7080	F-16	44		F-8	12
5310-00-241-6604	F-8	2	5310-00-905-1691	F-6	10
7330-00-248-1153	F-16	19		F-7	8
7330-00-250-6300	F-16	3	5310-00-929-1807	F-4	3
7330-00-254-4793	F-16	18	5320-00-957-5819	F-8	7
7330-00-256-2158	F-16	10	5320-00-962-4693	F-4	21
7330-00-257-4822	F-16	32	7310-00-999-2552	F-10	2
7330-00-263-8516	F-16	26	5320-01-015-6896	F-4	16
7330-00-266-7453	F-16	2		F-4	17
4610-00-268-9890	F-17	1		F-4	23
7330-00-272-2489	F-16	8	7310-01-107-1281	F-16	6
7330-00-272-2589	F-16	25	7310-01-113-9172	F-10	1
7330-00-272-7876	F-16	23	8340-01-185-2613	F-1	1
7340-00-272-9586	F-16	39	5320-01-192-2248	F-8	14
7360-00-274-7088	F-16	36	7320-01-213-6160	F-13	3
7330-00-292-2306	F-16	33		F-14	8
7330-00-292-2307	F-16	34	7330-01-224-0914	F-16	21
7330-00-379-2544	F-16	43	7330-01-234-2163	F-14	1
7330-00-379-4439	F-16	35	7330-01-234-2164	F-16	20
7340-00-406-6531	F-16	17	7310-01-234-2189	F-16	28
5320-00-409-6841	F-4	19	7330-01-234-2204	F-11	4
5320-00-417-5827	F-9	3	7310-01-235-0922	F-16	4
5305-00-456-2430	F-6	11	7330-01-236-3155	F-11	1
	F-7	9	4730-01-241-3444	F-8	17
5340-00-484-0383	F-8	8	7330-01-245-0201	F-16	24
7330-00-485-7376	F-16	27	7310-01-245-6937	F-13	1
7340-00-488-7939	F-16	16	7320-01-245-9048	F-13	7
7340-00-488-7950	F-16	14	7360-01-248-5292	F-8	5
5305-00-497-7401	F-13	5	7360-01-248-6041	F-8	1

## CROSS-REFERENCE INDEXES

STOCK NUMBER	FIG.	NATIONAL STOCK NUMBER INDEX		FIG.	ITEM
		ITEM	STOCK NUMBER		
9905-01-248-8730	F-4		28		
	F-4		30		
	F-6		14		
	F-7		12		
	F-8		13		
	F-9		4		
7360-01-248-8733	F-11		3		
7360-01-248-9890	F-14		6		
9905-01-248-9907	F-8		11		
7330-01-248-9964	F-9		1		
7330-01-249-1959	F-9		2		
5340-01-249-6786	F-13		6		
5340-01-249-6787	F-14		3		
7360-01-250-3649	F-5		1		
	F-9		5		
7360-01-250-3652	F-5		2		
	F-9		6		
7330-01-250-7730	F-13		8		
5330-01-255-2588	F-13		4		
5330-01-255-2589	F-14		7		
7320-01-255-8174	F-13		2		
5340-01-258-4534	F-14		5		
5340-01-333-8486	F-12		6		
7105-01-333-8493	F-12		1		
7125-01-333-8494	F-3		4		
7105-01-333-8495	F-3		2		
7125-01-334-3159	F-3		1		
5340-01-334-5088	F-3		3		
7240-01-337-5269	F-17		2		
7310-01-348-3191	F-6		8		
	F-7		6		
7310-01-348-3192	F-6		15		
	F-7		13		
5320-01-354-4708	F-15		4		
	F-15		6		
5320-01-354-8787	F-15		2		
5325-01-355-2638	F-15		3		
7105-01-361-8564	F-12		4		
5330-01-367-6231	BULK		2		
5340-01-367-9154	F-4		5		
5340-01-367-9185	F-4		2		
7125-01-372-0102	F-15		1		
5340-01-374-5671	F-7		4		
7310-01-375-6762	F-4		8		
5340-01-376-9579	F-6		5		
5640-01-383-7649	BULK		1		



## SECTION IV

## CROSS-REFERENCE INDEXES

## PART NUMBER INDEX

CAGEC	PART NUMBER	STOCK NUMBER	FIG.	ITEM
58536	A-A--50171	7330-00-543-7097	F-16	7
58536	A-A-1072	7330-00-680-2635	F-16	41
58536	A-A-1077	7330-00-272-2489	F-16	8
58536	A-A-1082	7340-00-240-7080	F-16	44
		7340-00-205-1421	F-16	46
58536	A-A-1751	7330-00-205-3096	F-16	22
58536	A-A-1954	7330-00-272-7876	F-16	23
58536	A-A-1956	7330-00-254-4793	F-16	18
		7330-00-248-1153	F-16	19
58536	A-A-2368	7330-00-153-9749	F-16	37
58536	A-A-295	7240-00-151-6629	F-16	49
58536	A-A-391	7330-00-078-5706	F-16	1
58536	A-A-394	7330-00-815-1458	F-16	9
58536	A-A-467	7330-00-184-0089	F-16	40
58536	A-A-52068	7330-00-205-1950	F-16	38
58536	A-A-52078	6260-00-170-0430	F-2	1
58536	A-A-631	7330-00-257-4822	F-16	32
88044	AN960-C416	5310-00-531-9515	F-8	3
56023	FC-120	7310-00-834-4480	F-16	5
56023	FC-280	7310-01-107-1281	F-16	6
99017	FP-166	5340-01-334-5088	F-3	3
80244	GGG-C-746 TY20GRD	7340-00-488-7950	F-16	14
80244	GGG-C-746 TY21GRD	7340-00-272-9586	F-16	39
80244	GGG-C-746 TY5GRD	7340-00-488-7939	F-16	16
80244	GGG-C-746 TY6GRD	7340-00-406-6531	F-16	17
80244	GGG-K-494TY2	5110-00-892-5071	F-16	15
81851	GW604-1/4X1 INCH	5330-01-367-6231	BULK	2
98003	HA956-LS-2-RG		F-15	7
98003	H560-LS-2-RG		F-15	5
83190	I SUPPORT PLATE	7360-01-248-8733	F-11	3
83190	K004	7330-01-234-2204	F-11	4
81349	MIL-B-40098	7310-01-113-9172	F-10	1
81337	MIL-C-43613	7240-00-089-7312	F-17	3
81349	MIL-C-53109	7240-01-337-5269	F-17	2
81349	MIL-P-12851	7330-00-272-2589	F-16	25
81349	MIL-P-1 735	7330-00-250-6300	F-16	3
80244	MIL-P-1735 SZ1	7330-00-292-2306	F-16	33
80244	MIL-P-1735 SZ2	7330-00-292-2307	F-16	34
81349	MIL-P-1747	7330-00-485-7376	F-16	27
80244	MIL-P-1 747TM2	7330-00-263-8516	F-16	26
81349	MIL-R-1 982	7360-00-274-7088	F-16	36
81349	MIL-T-44271	8340-01-185-2613	F-1	1
80244	MIL-U-10815 TY1SZ1	7340-00-223-7791	F-16	11
80244	MIL-U-10815 TY1SZ2	7340-00-223-7792	F-16	12
80244	MIL-U-10815 TY2SZ2	7340-00-223-7800	F-16	45
80244	MIL-U-10815 TY4SZ2	7330-00-256-2158	F-16	10

SECTION IV

CROSS-REFERENCE INDEXES

PART NUMBER INDEX

CAGEC	PART NUMBER	STOCK NUMBER	FIG.	ITEM
81349	MILB273	4610-00-268-9890	F-17	1
21669	MP-C-30-H	7310-01 -235-0922	F-16	4
21669	MP36	7310-01-234-2189	F-16	28
96906	MS17830-4C	5310-00-241-6604	F-8	2
96906	MS20426A4-4C	5320-01-354-8787	F-15	2
96906	MS20426A6-5	5320-00-685-0273	F-8	6
96906	MS20470AD4-5C	5320-01-354-4708	F-15	4
96906	MS20470A6-5C	5320-01-354-4708	F-15	6
96906	MS20604-B6W4	5320-00-957-5819	F-8	7
96906	MS24628-64	5305-00-562-2750	F-8	9
96906	MS24662-173	5320-01-192-2248	F-8	14
96906	MS27020-8		F-7	5
96906	MS35307-306	5305-00-702-4523	F-4	6
			F-8	4
96906	MS35307-310	5305-00-021-3668	F-4	4
96906	MS35308-310	5305-00-456-2430	F-6	11
			F-7	9
96906	MS35335-61	5310-00-527-3634	F-12	3
96906	MS35791-2	5340-00-682-1502	F-8	10
96906	MS51861-25C	5305-00-497-7401	F-13	5
96906	MS51861-26C	5305-00-147-3232	F-14	2
96906	MS51922-2	5310-00-929-1807	F-4	3
96906	MS51957-30	5305-00-054-6654	F-4	9
96906	MS51957-62	5305-00-050-9228	F-11	2
96906	MS51958-61	5305-00-059-3657	F-14	4
96906	MS51971-1	5310-00-903-5966	F-12	2
96906	MS51972-1	5310-00-905-1691	F-6	10
			F-7	8
81 349	M24243/1-A606	5320-00-962-4693	F-4	21
81349	M24243/1-B402	5320-00-510-7823	F-4	15
			F-6	13
			F-7	11
81349	M24243/1-B403	5320-00-904-4136	F-4	27
			F-4	29
			F-8	12
81349	M24243/1-B404	5320-01-015-6896	F-4	16
			F-4	17
			F-4	23
81349	M24243/1-B606	5320-00-409-6841	F-4	19
81349	M24243/6-A401 H	5320-00-417-5827	F-9	3
19099	NO NUMBER		F-16	
19099	NO REF	7330-00-849-5194	F-16	42
97074	PANHANDLER	7330-00-3794439	F-16	35
75165	TYPE126CERAFORM, 0.50THK, 24X481N	5640-01-383-7649	BULK	1
85812	W8079	7330-00-238-8316	F-16	31
21669	12101	5330-01-255-2588	F-13	4
21669	12109	5330-01-255-2589	F-14	7
56023	124	7310-00-238-5164	F-16	29
21669	14200	7320-01-213-6160	F-13	3

SECTION IV

CROSS-REFERENCE INDEXES

CAGEC	PART NUMBER	PART NUMBER INDEX STOCK NUMBER	FIG.	ITEM
81337	2-9-120PT224	7330-00-379-2544	F-16	43
21669	200MPC1 -G	7330-01-234-2163	F-14	1
56023	224	7310-00-576-4614	F-16	30
98003	3HC-83314442-6	5325-01-355-2638	F-15	3
98991	4211T3-4	4820-00-902-2829	F-8	18
21669	46002	7320-01-245-9048	F-13	7
81337	5-11-1232 PIECE 5-10	7310-00-999-2552	F-10	2
81337	5-13-3721	7360-01-248-6041	F-8	1
81337	5-13-3732	7360-01-248-5292	F-8	5
81337	5-13-3733		F-8	16
81337	5-13-3744	5340-01-374-5671	F-7	4
81337	5-13-3753	4730-01-241-3444	F-8	17
81337	5-13-3769		F-8	15
81337	5-13-3771	9905-01-248-9907	F-8	11
81337	5-13-3773	9905-01-248-8730	F-4	28
			F-4	30
			F-6	14
			F-7	12
			F-8	13
			F-9	4
81337	5-13-3859	7330-01-224-0914	F-16	21
81337	5-13-3868	7360-01-250-3652	F-5	2
			F-9	6
81337	5-13-3875	7360-01-250-3649	F-5	1
			F-9	5
81337	5-13-3886	7330-01-249-1959	F-9	2
81337	5-13-3961	7330-01-234-2164	F-16	20
81337	5-13-3969	7330-01-236-3155	F-11	1
81337	5-13-3971	7330-01-245-0201	F-16	24
81337	5-13-3991	7330-01-248-9964	F-9	1
81337	5-13-4050	7125-01-334-3159	F-3	1
81337	5-13-4051	7125-01-333-8494	F-3	4
81337	5-13-4053	7105-01-333-8495	F-3	2
81337	5-13-4100		F-4	1
32682	5-13-4100CABINET		F-4	31
81337	5-13-4101	7310-01-375-6762	F-4	8
81337	5-13-4104		F-4	20
81337	5-13-4106		F-4	14
81337	5-13-4108	5340-01-367-9154	F-4	5
81337	5-13-4110	5340-01-367-9185	F-4	2
81337	5-13-4117		F-4	12
81337	5-13-4160	7125-01-372-0102	F-15	1
81337	5-13-4165		F-4	11
81337	5-13-4169		F-4	24
81337	5-13-4170		F-4	25
81337	5-13-4171		F-4	7
81337	5-13-4172		F-4	18
81337	5-13-4174		F-4	10
81337	5-13-4186		F-4	22

## SECTION IV

## CROSS-REFERENCE INDEXES

CAGEC	PART NUMBER	PART NUMBER INDEX		FIG.	ITEM
			STOCK NUMBER		
81337	5-13-4210			F-6	1
81337	5-13-4211			F-6	6
81337	5-13-4212			F-7	1
81337	5-13-4213			F-7	3
81337	5-13-4218		7310-01-348-3191	F-6	8
				F-7	6
81337	5-13-4219			F-6	9
				F-7	7
81337	5-13-4228			F-6	12
				F-7	10
81337	5-13-4230		7310-01-348-3192	F-6	15
				F-7	13
81337	5-13-4235			F-6	2
81337	5-13-4236			F-6	7
81337	5-13-4237			F-6	4
81337	5-13-4238			F-6	3
81337	5-13-4239		5340-01-376-9579	F-6	5
81337	5-13-4242		7105-01-333-8493	F-12	1
81337	5-13-4243			F-12	5
81337	5-13-4245-1		7105-01-361-8564	F-12	4
81337	5-13-4254			F-7	2
81337	5-13-4257		5340-01-333-8486	F-12	6
21669	500LCD-G-G		7310-01-245-6937	F-13	1
21669	60012		5340-01-258-4534	F-14	5
21669	60028		5340-01-249-6786	F-13	6
21669	60029		5340-01-249-6787	F-14	3
21669	63226-G		7320-01-255-8174	F-13	2
21669	63416-G		7360-01-248-9890	F-14	6
21669	64003		7330-01-250-7730	F-13	8
14608	641-US2G		5340-00-484-0383	F-8	8
4Y739	6447M		7340-00-197-1271	F-16	13
80049	6921793900		7330-00-266-7453	F-16	2
09647	838A7511		7340-00-177-6154	F-16	47

## CROSS-REFERENCE INDEXES

FIG.	ITEM	FIGURE AND ITEM NUMBER INDEX		PART NUMBER
		STOCK NUMBER	CAGEC	
BULK	1	5640-01-383-7649	75165	TYPE126CERAFORM, 0.50THK,24X48IN
BULK	2	5330-01-367-6231	81851	GW604-1/4X1 INCH
F-1	1	8340-01-185-2613	81349	MIL-T-44271
F-2	1	6260-00-170-0430	81349	MIL-L-1594
F-3	1	7125-01-334-3159	81337	5-13-4050
F-3	2	7105-01-333-8495	81337	5-13-4053
F-3	3	5340-01-334-5088	99017	FP-166
F-3	4	7125-01-333-8494	81337	5-13-4051
F-4	1		81337	5-13-4100
F-4	2	5340-01-367-9185	81337	5-13-4110
F-4	3	5310-00-929-1807	96906	MS51922-2
F-4	4	5305-00-021-3668	96906	MS35307-310
F-4	5	5340-01-367-9154	81337	5-13-4108
F-4	6	5305-00-702-4523	96906	MS35307-306
F-4	7		81337	5-13-4171
F-4	8	7310-01-375-6762	81337	5-13-4101
F-4	9	5305-00-054-6654	96906	MS51957-30
F-4	10		81337	5-13-4174
F-4	11		81337	5-13-4165
F-4	12		81337	5-13-4117
F-4	14		81337	5-13-4106
F-4	15	5320-00-510-7823	81349	M24243/1-B402
F-4	16	5320-01-015-6896	81349	M24243/1-B404
F-4	17	5320-01-015-6896	81349	M24243/1-B404
F-4	18		81337	5-13-4172
F-4	19	5320-00-409-6841	81349	M24243/1-B606
F-4	20		81337	5-13-4104
F-4	21	5320-00-962-4693	81349	M24243/1-A606
F-4	22		81337	5-13-4186
F-4	23	5320-01-015-6896	81349	M24243/1-B404
F-4	24		81337	5-13-4169
F-4	25		81337	5-13-4170
F-4	27	5320-00-904-4136	81349	M24243/1-B403
F-4	28	9905-01-248-8730	81337	5-13-3773
F-4	29	5320-00-904-4136	81349	M24243/1-B403
F-4	30	9905-01-248-8730	81337	5-13-3773
F-4	31		32682	5-13-4100CABINET
F-5	1	7360-01-250-3649	81337	5-13-3875
F-5	2	7360-01-250-3652	81337	5-13-3868
F-6	1		81337	5-13-4210
F-6	2		81337	5-13-4235
F-6	3		81337	5-13-4238
F-6	4		81337	5-13-4237
F-6	5	5340-01-376-9579	81337	5-13-4239
F-6	6		81337	5-13-4211
F-6	7		81337	5-13-4236
F-6	8	7310-01-348-3191	81337	5-13-4218
F-6	9		81337	5-13-4219
F-6	10	5310-00-905-1691	96906	MS51972-1
F-6	11	5305-00-456-2430	96906	MS35308-310

## CROSS-REFERENCE INDEXES

FIG.	ITEM	FIGURE AND ITEM NUMBER INDEX		PART NUMBER
		STOCK NUMBER	CAGEC	
F-6	12		81337	5-13-4228
F-6	13	5320-00-510-7823	81349	M24243/1-B402
F-6	14	9905-01-248-8730	81337	5-13-3773
F-6	15	7310-01-348-3192	81337	5-13-4230
F-7	1		81337	5-13-4212
F-7	2		81337	5-13-4254
F-7	3		81337	5-13-4213
F-7	4	5340-01-374-5671	81337	5-13-3744
F-7	5		96906	MS27020-8
F-7	6	7310-01-348-3191	81337	5-13-4218
F-7	7		81337	5-13-4219
F-7	8	5310-00-905-1691	96906	MS51972-1
F-7	9	5305-00-456-2430	96906	MS35308-310
F-7	10		81337	5-13-4228
F-7	11	5320-00-510-7823	81349	M24243/1-B402
F-7	12	9905-01-248-8730	81337	5-13-3773
F-7	13	7310-01-348-3192	81337	5-13-4230
F-8	1	7360-01-248-6041	81337	5-13-3721
F-8	2	5310-00-241-6604	96906	MS17830-4C
F-8	3	5310-00-531-9515	88044	AN960-C416
F-8	4	5305-00-702-4523	96906	MS35307-306
F-8	5	7360-01-248-5292	81337	5-13-3732
F-8	6	5320-00-685-0273	96906	MS20426A6-5
F-8	7	5320-00-957-5819	96906	MS20604-B6W4
F-8	8	5340-00-484-0383	14608	641-US2G
F-8	9	5305-00-562-2750	96906	MS24628-64
F-8	10	5340-00-682-1502	96906	MS35791-2
F-8	11	9905-01-248-9907	81337	5-13-3771
F-8	12	5320-00-904-4136	81349	M24243/1-B403
F-8	13	9905-01-248-8730	81337	5-13-3773
F-8	14	5320-01-192-2248	96906	MS24662-173
F-8	15		81337	5-13-3769
F-8	16		81337	5-13-3733
F-8	17	4730-01-241-3444	81337	5-13-3753
F-8	18	4820-00-902-2829	98991	4211T3-4
F-9	1	7330-01-248-9964	81337	5-13-3991
F-9	2	7330-01-249-1959	81337	5-13-3886
F-9	3	5320-00-417-5827	81349	M24243/6-A401H
F-9	4	9905-01-248-8730	81337	5-13-3773
F-9	5	7360-01-250-3649	81337	5-13-3875
F-9	6	7360-01-250-3652	81337	5-13-3868
F-10	1	7310-01-113-9172	81349	MIL-B-40098
F-10	2	7310-00-999-2552	81337	5-11-1232 PIECE
F-11	1	7330-01-236-3155	81337	5-10
F-11	2	5305-00-050-9228	96906	5-13-3969
F-11	3	7360-01-248-8733	83190	MS51957-62
F-11	4	7330-01-234-2204	83190	I SUPPORT PLATE
F-12	1	7105-01-333-8493	81337	K004
F-12	2	5310-00-903-5966	96906	5-13-4242
F-12	3	5310-00-527-3634	96906	MS51971-1
				:S35335-61

## CROSS-REFERENCE INDEXES

FIG.	ITEM	FIGURE AND ITEM NUMBER INDEX		PART NUMBER
		STOCK NUMBER	CAGEC	
F-12	4	7105-01-361-8564	81337	5-13-4245-1
F-12	5		81337	5-13-4243
F-12	6	5340-01-333-8486	81337	5-13-4257
F-13	1	7310-01-245-6937	21669	50OLCD-G
F-13	2	7320-01-255-8174	21669	63226-G
F-13	3	7320-01-213-6160	21669	14200
F-13	4	5330-01-255-2588	21669	12101
F-13	5	5305-00-497-7401	96906	MS51861-25C
F-13	6	5340-01-249-6786	21669	60028
F-13	7	7320-01-245-9048	21669	46002
F-13	8	7330-01-250-7730	21669	64003
F-14	1	7330-01-234-2163	21669	200MPC1-G
F-14	2	5305-00-147-3232	96906	MS51861-26C
F-14	3	5340-01-249-6787	21669	60029
F-14	4	5305-00-059-3657	96906	MS51958-61
F-14	5	5340-01-258-4534	21669	60012
F-14	6	7360-01-248-9890	21669	63416-G
F-14	7	5330-01-255-2589	21669	12109
F-14	8	7320-01-213-6160	21669	14200
F-15	1	7125-01-372-0102	81337	5-13-4160
F-15	2	5320-01-354-8787	96906	MS20426A4-4C
F-15	3	5325-01-355-2638	98003	3HC-83314-42-6
F-15	4	5320-01-354-4708	96906	MS20470AD4-5C
F-15	5		98003	H560-LS-2-RG
F-15	6	5320-01-354-4708	96906	MS20470A6-5C
F-15	7		98003	HA956-LS-2-RG
F-16			19099	NO NUMBER
F-16	1	7330-00-078-5706	58536	A-A-391
F-16	2	7330-00-266-7453	80049	6921793900
F-16	3	7330-00-250-6300	81349	MIL-P-1735
F-16	4	7310-01-235-0922	21669	MP-C-30-H
F-16	5	7310-00-834-4480	56023	FC-120
F-16	6	7310-01-107-1281	56023	FC-280
F-16	7	7330-00-543-7097	58536	A-A--50171
F-16	8	7330-00-272-2489	58536	A-A-1077
F-16	9	7330-00-815-1458	58536	A-A-394
F-16	10	7330-00-256-2158	80244	MIL-U-10815 TY4S Z2
F-16	11	7340-00-223-7791	80244	MIL-U-10815 TY1S Z1
F-16	12	7340-00-223-7792	80244	MIL-U-10815 TY1S Z2
F-16	13	7340-00-197-1271	4Y739	6447M
F-16	14	7340-00-488-7950	80244	GGG-C-746 TY20GR D
F-16	15	5110-00-892-5071	80244	GGG-K-494TY2
F-16	16	7340-00-488-7939	80244	GGG-C-746 TYSGRD
F-16	17	7340-00-406-6531	80244	GGG-C-746 TY6GRD
F-16	18	7330-00-254-4793	58536	A-A-1956
F-16	19	7330-00-248-1153	58536	A-A-1956
F-16	20	7330-01-234-2164	81337	5-13-3961

## SECTION IV

## CROSS-REFERENCE INDEXES

FIG.	ITEM	FIGURE AND ITEM INDEX		PART NUMBER
		STOCK NUMBER	CAGEC	
F-16	21	7330-01-224-0914	81337	5-13-3859
F-16	22	7330-00-205-3096	58536	A-A-1751
F-16	23	7330-00-272-7876	58536	A-A-1954
F-16	24	7330-01-245-0201	81337	5-13-3971
F-16	25	7330-00-272-2589	81349	MIL-P-12851
F-16	26	7330-00-263-8516	80244	MIL-P-1747TM2
F-16	27	7330-00-485-7376	81349	MIL-P-1747
F-16	28	7310-01-234-2189	21669	MP36
F-16	29	7310-00-238-5164	56023	124
F-16	30	7330-00-576-4614	56023	224
F-16	31	7330-00-238-8316	85812	W8079
F-16	32	7330-00-257-4822	58536	A-A-631
F-16	33	7330-00-292-2306	80244	MIL-P-1735 SZ1
F-16	34	7330-00-292-2307	80244	MIL-P-1735 SZ2
F-16	35	7330-00-379-4439	97074	PANHANDLER
F-16	36	7360-00-274-7088	81349	MIL-R-1982
F-16	37	7330-00-153-9749	58536	A-A-2368
F-16	38	7330-00-205-1950	58536	A-A-52068
F-16	39	7340-00-272-9586	80244	GGG-C-746 TY21GRD
F-16	40	7330-00-184-0089	58536	A-A-467
F-16	41	7330-00-680-2635	58536	A-A-1072
F-16	42	7330-00-849-5194	19099	NO REF
F-16	43	7330-00-379-2544	81337	2-9-120PT224
F-16	44	7340-00-240-7080	58536	A-A-1082
F-16	45	7340-00-223-7800	80244	MIL-U-10815 TY2SZ2
F-16	46	7340-00-205-1421	58536	A-A-1 082
F-16	47	7240-00-177-6154	09647	838A7511
F-16	49	7240-00-151-6629	58536	A-A-295
F-17	1	4610-00-268-9890	81349	MILB273
F-17	2	7240-01-337-5269	81349	MIL-C-53109
F-17	3	7240-00-089-7312	81337	MIL-C-43613



**APPENDIX G**

**ILLUSTRATED LIST OF MANUFACTURED ITEMS**

**G-1. INTRODUCTION.**

a. This appendix includes complete instructions for making items authorized to be manufactured or fabricated at organizational maintenance (or aviation unit maintenance, if applicable).

b. A part number index in alphanumeric order is provided for cross-referencing the part number of the item to be manufactured to the figure which covers fabrication criteria.

c. All bulk materials needed for manufacture of an item are listed by part number or specification number on the illustration (See Notes on illustration).

**G-2. MANUFACTURED ITEMS PART NUMBER INDEX.**

MANUFACTURED ITEM NO.	BULK MATERIAL PART NO.	FIGURE NO.
5-13-4100-24 (81337)	TYPE 126CERA FORM BOARD, 0.50 THK, 24 X 48 INCHES (75165)	G-1
5-13-4141 (81337)	GW604-1/4 X 1 INCH (81851)	G-2

OVEN  
INSULATION

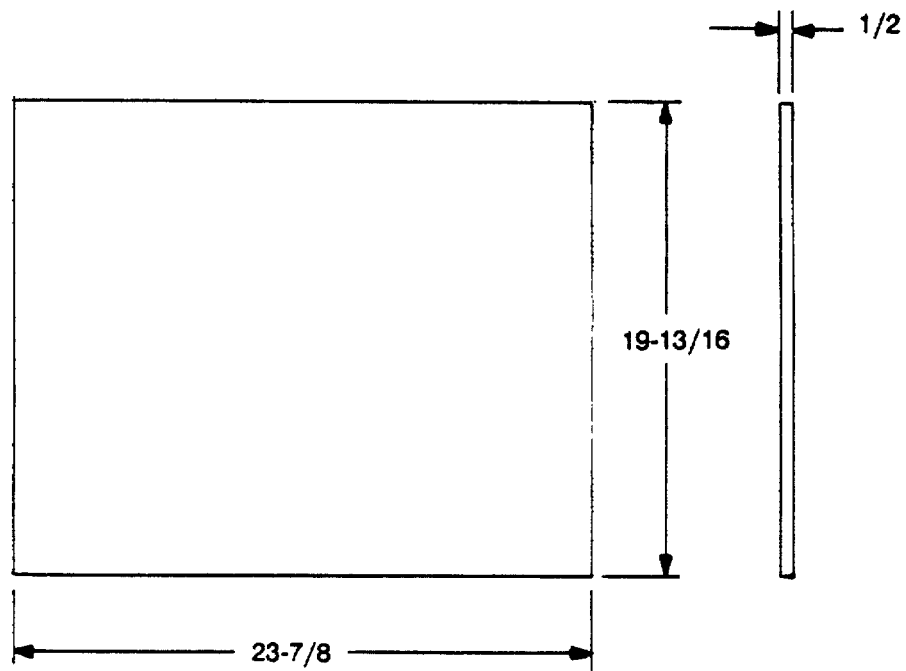

NOTES:

1. CUT TO SIZE FROM BULK MATERIAL INSULATION (75165) TYPE 126 CERA FORM BOARD, 0.50 THK, 24 X 48 INCHES.
2. ALL DIMENSIONS ARE IN INCHES.

Figure G-1. Insulation

OVEN DOOR  
GASKETS

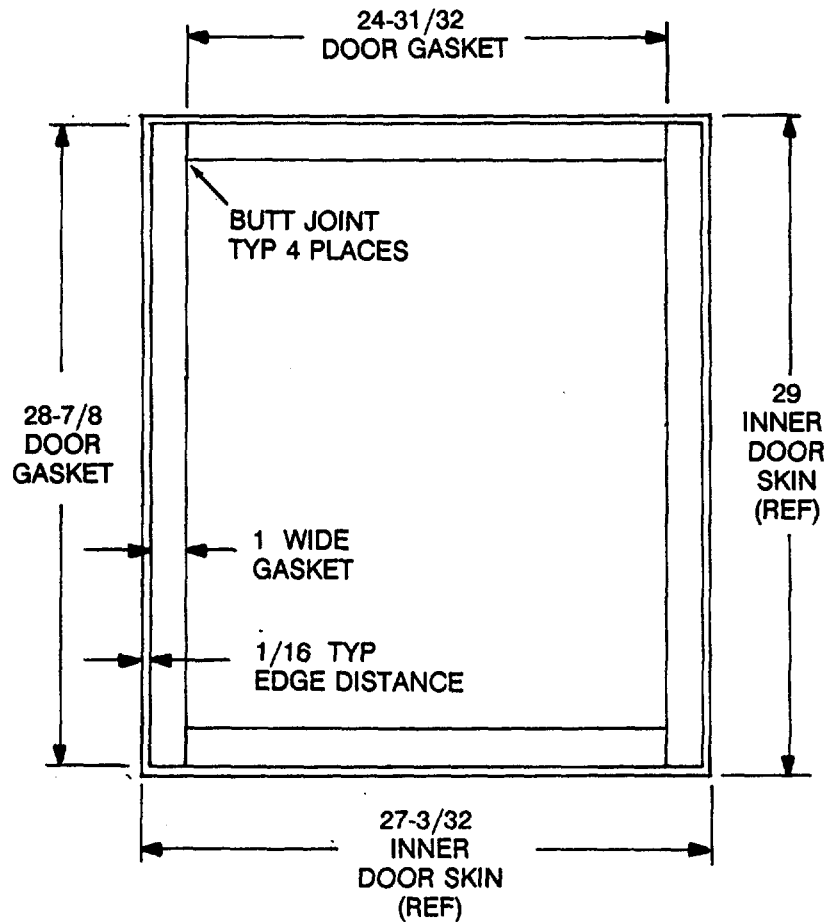

NOTES:

1. CUT TO CORRECT LENGTH FROM BULK MATERIAL GASKET (81851) GW604-1/4 X 1 INCH.
2. ALL DIMENSIONS ARE IN INCHES.
3. OVEN DOOR IS SHOWN FOR REFERENCE ONLY AND TO INDICATE ASSEMBLY OF GASKETS TO DOOR.

Figure G-2. Gasket



INDEX

	Paragraph	Page
Additional Authorization List .....	Appendix D	D-1
Administrative Storage .....	4-20	4-21/(4-22 blank)
Assembly and Preparation for Use .....	2-6	2-8
Characteristics, Capabilities and Features, Equipment .....	1-7	1-5
Cleaning and Sanitation .....	3-7	3-4
Components of End Item and Basic Issue Items List .....	Appendix C	C-1
Controls and Indicators.....	2-2	2-2
Cooking Pot Cradle Assembly .....	1-14	1-9/(1-10 blank)
Destruction of Army Material to Prevent Enemy Use.....	1-4	1-4
Direct Support Maintenance, Scope of .....	5-1	5-2
Disassembly and Preparation for Movement .....	2-8	2-33
Equipment Data .....	1-9	1-6
Equipment Improvement Recommendations (EIR's), Reporting .....	1-3	14
Expendable/Durable Supplies and Materials List .....	Appendix E	E-1
Food Container and Liquid Dispensers .....	1-17	1-9/(1-10 blank)
Forms and Records, Maintenance .....	1-2	1-4
Griddle Assembly .....	1-11	1-9/(1-10 blank)
Heater Tank Assembly .....	1-13	1-9/(1-10 blank)
Illustrated List of Manufactured Items.....	Appendix G	G-1
Location and Description of Major Components.....	1-8	1-6
Lubrication Procedures.....	3-2	3-2
Maintenance Allocation Chart.....	Appendix B	B-1
Maintenance Procedures.....	3-6	3-4
Maintenance Procedures, Unit .....	Section V	4-6
M2 Burner Units .....	1-15	1-9/(1-10 blank)
Nomenclature/Common Name Cross-Reference List .....	1-6	1-5
Operation Under Unusual Conditions		
Dusty or Sandy Areas .....	2-17	2-61/(2-62 blank)
Extreme Cold.....	2-11	2-60
Extreme Heat.....	2-16	2-61/(2-62 blank)
High Altitudes .....	2-14	2-61/(2-62 blank)
Rainy or Humid Conditions .....	2-12	2-61/(2-62 blank)
Salt Water Areas .....	2-13	2-61/(2-62 blank)
Windy Conditions.....	2-15	2-61/(2-62 blank)
Operating Procedures .....	2-7	2-21
Operation Under Usual Conditions .....	Section III	2-8
Oven Assembly.....	1-10	1-9/(1-10 blank)
PMCS Procedures.....	2-3b	2-3
PMCS Introduction .....	2-3	2-3
PMCS Procedures, Unit .....	4-7	4-3
Packaging .....	2-9	2-39
Packing for Shipment.....	4-22	4-21/(4-22 blank)
Preparation for Storage or Shipment .....	4-21	4-21/(4-22 blank)
References.....	Appendix A	A-1
Repair Parts .....	4-3	4-2
Repair Parts and Special Tools List.....	Appendix F	F-1
Rivet Replacement.....	5-3	5-2
Rivet Removal .....	5-2	5-2
Scope .....	1-1	1-4
Service Upon Receipt .....	Section II	4-2
Site Selection.....	2-5	2-8
Steam Table Assembly .....	1-12	1-9/(1-10 blank)
Sterilizing Water Bag .....	1-20	1-9/(1-10 blank)

INDEX (CONT)

	Paragraph	Page
Tools and Equipment		
Common Tools and Equipment.....	4-1	4-2
Special Tools, Test, Measurement, and Diagnostic Equipment (TMDE), and Support Equipment.....	4-2	4-2
Tray-Pack Lifter .....	1-18	1-9/(1-10 blank)
Tray-Pack Serving Lifter .....	1-19	1-9/(1-10 blank)
Tray-Packs.....	1-21	1-9/(1-10 blank)
Troubleshooting Procedures, Operator's.....	Section II	3-2
Troubleshooting Procedures, Unit .....	Section IV	4-3
Unpacking.....	4-4	4-2
Welding .....	5-4	5-3/(5-4 blank)
Work Table .....	1-16	1-9/(1-10 blank)

By Order of the Secretary of the Army:

**GORDON R. SULLIVAN**  
*General, United States Army*  
*Chief of Staff*

Official:

**PATRICIA P. HICKERSON**  
*Brigadier General, United States Army*  
*The Adjutant General*

DISTRIBUTION:

To be distributed in accordance with DA Form 12-25A, Operator, Unit, and Direct Support Maintenance requirements for Kitchen, Field, Mobile, Trailer Mounted (MKT-75).





## ***These are the instructions for sending an electronic 2028***

The following format must be used if submitting an electronic 2028. The subject line must be exactly the same and all fields must be included; however only the following fields are mandatory: 1, 3, 4, 5, 6, 7, 8, 9, 10, 13, 15, 16, 17, and 27.

From: "Whomever" <whomever@avma27.army.mil>

To: amssbriml@natick.army.mil

Subject: DA Form 2028

1. From: Joe Smith
2. Unit: home
3. Address: 4300 Park
4. City: Hometown
5. St: MO
6. Zip: 77777
7. Date Sent: 19-OCT-93
8. Pub no: 55-2840-229-23
9. Pub Title: TM
10. Publication Date: 04-JUL-85
11. Change Number: 7
12. Submitter Rank: MSG
13. Submitter FName: Joe
14. Submitter MName: T
15. Submitter LName: Smith
16. Submitter Phone: 123-123-1234
17. Problem: 1
18. Page: 2
19. Paragraph: 3
20. Line: 4
21. NSN: 5
22. Reference: 6
23. Figure: 7
24. Table: 8
25. Item: 9
26. Total: 123
27. Text:

This is the text for the problem below line 27.



<b>RECOMMENDED CHANGES TO PUBLICATIONS AND BLANK FORMS</b> For use of this form, see AR 25-30; the proponent agency is ODISC4.						Use Part II (reverse) for Repair Parts and Special Tool Lists (RPSTL) and Supply Catalogs/Supply Manuals (SC/SM).	<b>DATE</b> 21 October 2003
<b>TO:</b> (Forward to proponent of publication or form) (Include ZIP Code) COMMANDER U.S. ARMY TANK-AUTOMOTIVE AND ARMAMENT COMMAND ATTN: AMSTA-LC-CECT 15 KANSAS STREET NATICK, MA 01760-5052						<b>FROM:</b> (Activity and location) (Include ZIP Code)  <i>PFC Jane Doe</i> <i>CO A 3<sup>rd</sup> Engineer BR</i> <i>Ft. Leonardwood, MO 63108</i>	
<b>PART I – ALL PUBLICATIONS (EXCEPT RPSTL AND SC/SM) AND BLANK FORMS</b>							
<b>PUBLICATION/FORM NUMBER</b> TM 10-1670-296-23&P				<b>DATE</b> 30 October 2002	<b>TITLE</b> Unit Manual for Ancillary Equipment for Low Velocity Air Drop Systems		
<b>ITEM NO.</b>	<b>PAGE NO.</b>	<b>PARA-GRAPH</b>	<b>LINE NO. *</b>	<b>FIGURE NO.</b>	<b>TABLE NO.</b>	<b>RECOMMENDED CHANGES AND REASON</b> <i>(Provide exact wording of recommended changes, if possible).</i>	
	0036 00-2				1	<i>In table 1, Sewing Machine Code Symbols, the second sewing machine code symbol should be MD ZZ not MD 22.</i>  <i>Change the manual to show Sewing Machine, Industrial: Zig-Zag; 308 stitch; medium-duty; NSN 3530-01-181-1421 as a MD ZZ code symbol.</i>	
<small>*Reference to line numbers within the paragraph or subparagraph.</small>							
<b>TYPED NAME, GRADE OR TITLE</b>  Jane Doe, PFC				<b>TELEPHONE EXCHANGE/AUTOVON, PLUS EXTENSION</b>  508-233-4141		<b>SIGNATURE</b>  Jane Doe <i>Jane Doe</i>	

<b>TO:</b> <i>(Forward direct to addressee listed in publication)</i> COMMANDER U.S. ARMY TANK-AUTOMOTIVE AND ARMAMENT COMMAND ATTN: AMSTA-LC-CECT 15 KANSAS STREET NATICK, MA 01760-5052	<b>FROM:</b> <i>(Activity and location) (Include ZIP Code)</i> <i>PFC Jane Doe</i> <i>CO A 3<sup>rd</sup> Engineer BR</i> <i>Ft. Leonardwood, MO 63108</i>	<b>DATE</b> <i>21 October 2003</i>
--	---	---------------------------------------

**PART II – REPAIR PARTS AND SPECIAL TOOL LISTS AND SUPPLY CATALOGS/SUPPLY MANUALS**

<b>PUBLICATION NUMBER</b> TM 10-1670-296-23&P	<b>DATE</b> 30 October 2002	<b>TITLE</b> Unit Manual for Ancillary Equipment for Low Velocity Air Drop Systems
--	--------------------------------	---

PAGE NO.	COLM NO.	LINE NO.	NATIONAL STOCK NUMBER	REFERENCE NO.	FIGURE NO.	ITEM NO.	TOTAL NO. OF MAJOR ITEMS SUPPORTED	RECOMMENDED ACTION
0066 00-1					4			<i>Callout 16 in figure 4 is pointed to a <u>D-Ring</u>. In the Repair Parts List key for figure 4, item 16 is called a <u>Snap Hook</u>. Please correct one or the other.</i>

SAMPLE

**PART III – REMARKS** *(Any general remarks or recommendations, or suggestions for improvement of publications and blank forms. Additional blank sheets may be used if more space is needed.)*

TYPED NAME, GRADE OR TITLE	TELEPHONE EXCHANGE/AUTOVON, PLUS EXTENSION	SIGNATURE
----------------------------	--	-----------

<p align="center"><b>RECOMMENDED CHANGES TO PUBLICATIONS AND BLANK FORMS</b></p> <p>For use of this form, see AR 25-30; the proponent agency is ODISC4.</p>						Use Part II (reverse) for Repair Parts and Special Tool Lists (RPSTL) and Supply Catalogs/Supply Manuals (SC/SM).	DATE
<b>TO:</b> (Forward to proponent of publication or form) (Include ZIP Code) COMMANDER U.S. ARMY TANK-AUTOMOTIVE AND ARMAMENT COMMAND ATTN: AMSTA-LC-CECT 15 KANSAS STREET NATICK, MA 01760-5052						<b>FROM:</b> (Activity and location) (Include ZIP Code)	
<b>PART I – ALL PUBLICATIONS (EXCEPT RPSTL AND SC/SM) AND BLANK FORMS</b>							
PUBLICATION/FORM NUMBER TM 10-7360-208-13&P						DATE 9 September 1991	TITLE Operator's, Unit, and Direct Support Maintenance Manual Including Repair Parts and Special Tools List for Modular Field Kitchen (MFK) NSN 7360-01-276-9817 (EIC:YCD)
ITEM NO.	PAGE NO.	PARA-GRAPH	LINE NO. *	FIGURE NO.	TABLE NO.	RECOMMENDED CHANGES AND REASON <i>(Provide exact wording of recommended changes, if possible).</i>	
*Reference to line numbers within the paragraph or subparagraph.							
TYPED NAME, GRADE OR TITLE				TELEPHONE EXCHANGE/AUTOVON, PLUS EXTENSION		SIGNATURE	

<b>TO:</b> <i>(Forward direct to addressee listed in publication)</i> COMMANDER U.S. ARMY TANK-AUTOMOTIVE AND ARMAMENT COMMAND ATTN: AMSTA-LC-CECT 15 KANSAS STREET NATICK, MA 01760-5052	<b>FROM:</b> <i>(Activity and location) (Include ZIP Code)</i>	<b>DATE</b>
--	--	-------------

**PART II – REPAIR PARTS AND SPECIAL TOOL LISTS AND SUPPLY CATALOGS/SUPPLY MANUALS**

<b>PUBLICATION NUMBER</b> TM 10-7360-208-13&P	<b>DATE</b> 9 September 1991	<b>TITLE</b> Operator's, Unit, and Direct Support Maintenance Manual Including Repair Parts and Special Tools List for Modular Field Kitchen (MFK) NSN 7360-01-276-9817 (EIC:YCD)
--	---------------------------------	--

PAGE NO.	COLM NO.	LINE NO.	NATIONAL STOCK NUMBER	REFERENCE NO.	FIGURE NO.	ITEM NO.	TOTAL NO. OF MAJOR ITEMS SUPPORTED	RECOMMENDED ACTION

**PART III – REMARKS** *(Any general remarks or recommendations, or suggestions for improvement of publications and blank forms. Additional blank sheets may be used if more space is needed.)*

TYPED NAME, GRADE OR TITLE	TELEPHONE EXCHANGE/AUTOVON, PLUS EXTENSION	SIGNATURE
----------------------------	--	-----------

<b>RECOMMENDED CHANGES TO PUBLICATIONS AND BLANK FORMS</b>						Use Part II (reverse) for Repair Parts and Special Tool Lists (RPSTL) and Supply Catalogs/Supply Manuals (SC/SM).	DATE
For use of this form, see AR 25-30; the proponent agency is ODISC4.							
<b>TO:</b> (Forward to proponent of publication or form) (Include ZIP Code) COMMANDER U.S. ARMY TANK-AUTOMOTIVE AND ARMAMENT COMMAND ATTN: AMSTA-LC-CECT 15 KANSAS STREET NATICK, MA 01760-5052						<b>FROM:</b> (Activity and location) (Include ZIP Code)	
<b>PART I – ALL PUBLICATIONS (EXCEPT RPSTL AND SC/SM) AND BLANK FORMS</b>							
PUBLICATION/FORM NUMBER TM 10-7360-208-13&P				DATE 9 September 1991		TITLE Operator's, Unit, and Direct Support Maintenance Manual Including Repair Parts and Special Tools List for Modular Field Kitchen (MFK) NSN 7360-01-276-9817 (EIC:YCD)	
ITEM NO.	PAGE NO.	PARA-GRAPH	LINE NO. *	FIGURE NO.	TABLE NO.	RECOMMENDED CHANGES AND REASON <i>(Provide exact wording of recommended changes, if possible).</i>	
<i>*Reference to line numbers within the paragraph or subparagraph.</i>							
TYPED NAME, GRADE OR TITLE				TELEPHONE EXCHANGE/AUTOVON, PLUS EXTENSION		SIGNATURE	

<b>TO:</b> <i>(Forward direct to addressee listed in publication)</i> COMMANDER U.S. ARMY TANK-AUTOMOTIVE AND ARMAMENT COMMAND ATTN: AMSTA-LC-CECT 15 KANSAS STREET NATICK, MA 01760-5052	<b>FROM:</b> <i>(Activity and location) (Include ZIP Code)</i>	<b>DATE</b>
--	--	-------------

**PART II – REPAIR PARTS AND SPECIAL TOOL LISTS AND SUPPLY CATALOGS/SUPPLY MANUALS**

<b>PUBLICATION NUMBER</b> TM 10-7360-208-13&P	<b>DATE</b> 9 September 1991	<b>TITLE</b> Operator's, Unit, and Direct Support Maintenance Manual Including Repair Parts and Special Tools List for Modular Field Kitchen (MFK) NSN 7360-01-276-9817 (EIC:YCD)
--	---------------------------------	--

PAGE NO.	COLM NO.	LINE NO.	NATIONAL STOCK NUMBER	REFERENCE NO.	FIGURE NO.	ITEM NO.	TOTAL NO. OF MAJOR ITEMS SUPPORTED	RECOMMENDED ACTION

**PART III – REMARKS** *(Any general remarks or recommendations, or suggestions for improvement of publications and blank forms. Additional blank sheets may be used if more space is needed.)*

TYPED NAME, GRADE OR TITLE	TELEPHONE EXCHANGE/AUTOVON, PLUS EXTENSION	SIGNATURE
----------------------------	--	-----------



<b>RECOMMENDED CHANGES TO PUBLICATIONS AND BLANK FORMS</b>						Use Part II (reverse) for Repair Parts and Special Tool Lists (RPSTL) and Supply Catalogs/Supply Manuals (SC/SM).	DATE
For use of this form, see AR 25-30; the proponent agency is ODISC4.							
<b>TO:</b> (Forward to proponent of publication or form) (Include ZIP Code) COMMANDER U.S. ARMY TANK-AUTOMOTIVE AND ARMAMENT COMMAND ATTN: AMSTA-LC-CECT 15 KANSAS STREET NATICK, MA 01760-5052						<b>FROM:</b> (Activity and location) (Include ZIP Code)	
<b>PART I – ALL PUBLICATIONS (EXCEPT RPSTL AND SC/SM) AND BLANK FORMS</b>							
PUBLICATION/FORM NUMBER TM 10-7360-208-13&P				DATE 9 September 1991		TITLE Operator's, Unit, and Direct Support Maintenance Manual Including Repair Parts and Special Tools List for Modular Field Kitchen (MFK) NSN 7360-01-276-9817 (EIC:YCD)	
ITEM NO.	PAGE NO.	PARA-GRAPH	LINE NO. *	FIGURE NO.	TABLE NO.	RECOMMENDED CHANGES AND REASON <i>(Provide exact wording of recommended changes, if possible).</i>	
<i>*Reference to line numbers within the paragraph or subparagraph.</i>							
TYPED NAME, GRADE OR TITLE				TELEPHONE EXCHANGE/AUTOVON, PLUS EXTENSION		SIGNATURE	

<b>TO:</b> <i>(Forward direct to addressee listed in publication)</i> COMMANDER U.S. ARMY TANK-AUTOMOTIVE AND ARMAMENT COMMAND ATTN: AMSTA-LC-CECT 15 KANSAS STREET NATICK, MA 01760-5052	<b>FROM:</b> <i>(Activity and location) (Include ZIP Code)</i>	<b>DATE</b>
--	--	-------------

**PART II – REPAIR PARTS AND SPECIAL TOOL LISTS AND SUPPLY CATALOGS/SUPPLY MANUALS**

<b>PUBLICATION NUMBER</b> TM 10-7360-208-13&P	<b>DATE</b> 9 September 1991	<b>TITLE</b> Operator's, Unit, and Direct Support Maintenance Manual Including Repair Parts and Special Tools List for Modular Field Kitchen (MFK) NSN 7360-01-276-9817 (EIC:YCD)
--	---------------------------------	--

PAGE NO.	COLM NO.	LINE NO.	NATIONAL STOCK NUMBER	REFERENCE NO.	FIGURE NO.	ITEM NO.	TOTAL NO. OF MAJOR ITEMS SUPPORTED	RECOMMENDED ACTION

**PART III – REMARKS** *(Any general remarks or recommendations, or suggestions for improvement of publications and blank forms. Additional blank sheets may be used if more space is needed.)*

TYPED NAME, GRADE OR TITLE	TELEPHONE EXCHANGE/AUTOVON, PLUS EXTENSION	SIGNATURE
----------------------------	--	-----------

## The Metric System and Equivalents

### *Linear Measure*

1 centimeter = 10 millimeters = .39 inches  
 1 decimeter = 10 centimeters = 3.94 inches  
 1 meter = 10 decimeters = 39.37 inches  
 1 dekameter = 10 meters = 32.8 feet  
 1 hectometer = 10 dekameters = 328.08 feet  
 1 kilometer = 10 hectometers = 3,280.8 feet

### *Liquid Measure*

1 centiliter = 10 milliliters = .34 fl. ounce  
 1 deciliter = 10 centiliters = 3.38 fl. ounces  
 1 liter = 10 deciliters = 33.81 fl. ounces  
 1 dekaliter = 10 liters = 2.64 gallons  
 1 hectoliter = 10 dekaliters = 26.42 gallons  
 1 kiloliter = 10 hectoliters = 264.18 gallons

### *Weights*

1 centigram = 10 milligrams = .15 grain  
 1 decigram = 10 centigrams = 1.54 grains  
 1 gram = 10 decigrams = .035 ounce  
 1 dekagram = 10 grams = .35 ounce  
 1 hectogram = 10 dekagrams = 3.52 ounces  
 1 kilogram = 10 hectograms = 2.2 pounds  
 1 quintal = 100 kilograms = 220.46 pounds  
 1 metric ton = 10 quintals = 1.1 short tons

### *Square Measure*

1 sq. centimeter = 100 sq. millimeters = .155 sq. inch  
 1 sq. decimeter = 100 sq. centimeters = 15.5 sq. inches  
 1 sq. meter (centare) = 100 sq. decimeters = 10.76 sq. ft.  
 1 sq. dekameter (are) = 100 sq. meters = 1,076.4 sq. feet  
 1 sq. hectometer (hectare) = 100 sq. dekameters = 2.47 acres  
 1 sq. kilometer = 100 sq. hectometers = .386 sq. mile

### *Cubic Measure*

1 cu. centimeter = 1000 cu. millimeters = .06 cu. Inch  
 1 cu. decimeter = 1000 cu. centimeters = 61.02 cu. inches  
 1 cu. meter = 1000 cu. decimeters = 35.31 cu. feet

### Approximate Conversion Factors

<i>To change</i>	<i>To</i>	<i>Multiply by</i>	<i>To change</i>	<i>To</i>	<i>Multiply by</i>
inches	centimeters	2.540	ounce-inches	newton-meters	.007062
feet	meters	.305	centimeters	inches	.394
yards	meters	.914	meters	feet	3.280
miles	kilometers	1.609	meters	yards	1.094
square inches	square centimeters	6.451	kilometers	miles	.621
square feet	square meters	.093	square centimeters	square inches	.155
square yards	square meters	.836	square meters	square feet	10.764
square miles	square kilometers	2.590	square meters	square yards	1.196
acres	square hectometers	.405	square kilometers	square miles	.386
cubic feet	cubic meters	.028	square hectometers	acres	2.471
cubic yards	cubic meters	.765	cubic meters	cubic feet	35.315
fluid ounces	milliliters	29.573	cubic meters	cubic yards	1.308
pints	liters	.473	milliliters	fluid ounces	.034
quarts	liters	.946	liters	pints	2.113
gallons	liters	3.785	liters	quarts	1.057
ounces	grams	28.349	liters	gallons	.264
pounds	kilograms	.454	grams	ounces	.035
short tons	metric tons	.907	kilograms	pounds	2.205
pounds-feet	newton-meters	1.356	metric tons	short tons	1.102
pound-inches	newton-meters	.11296			

### Temperature (Exact)

°F	Fahrenheit temperature	5/9 (after subtracting 32)	Celsius temperature	°C
----	---------------------------	-------------------------------	------------------------	----

**PIN: 068884-000**